

CE-551TB

Semi-Automatic Case Taper



- Top and Bottom Belts
- 2 Heavy Duty 120W Motors
- Heavy Duty Tape Heads
- Heavy Duty Belts
- Heavy Duty Gears
- 16 inch Infeed /Exit Tables
- 4 Casters Included
- Breaker Switch
- Emergency Stop

Best Value on the Market PERIOD!!!

The CE-551TB uniform semi-automatic carton sealer can be adjusted quickly and easily to the width and height of the box that you are sealing. This carton sealer works best when sealing many boxes of the same size in each production run.

Featuring two heavy-duty, 120-watt motors with 110 volts and 50/60 hertz of power. This carton/box sealer uses both a top and bottom belt drive to quickly move boxes and packages through the sealing process. Each CE-551TB carton sealer can seal boxes as small as 6.5 inches wide by 5 inches high and as large as 19.6 inches wide by 19.6 inches high.

- Suitable for wide and heavy cartons up to 75 lbs
- Manual width / height adjustment
- Top & bottom drive belts
- Includes 16" long infeed / exit trays



- Emergency Stop Switch
- Breaker Switch



Leg Height Adjustment



866-888-6327

sales@clevelandequipment.com

www.clevelandequipment.com

CE-551TB Semi-Automatic Case Taper

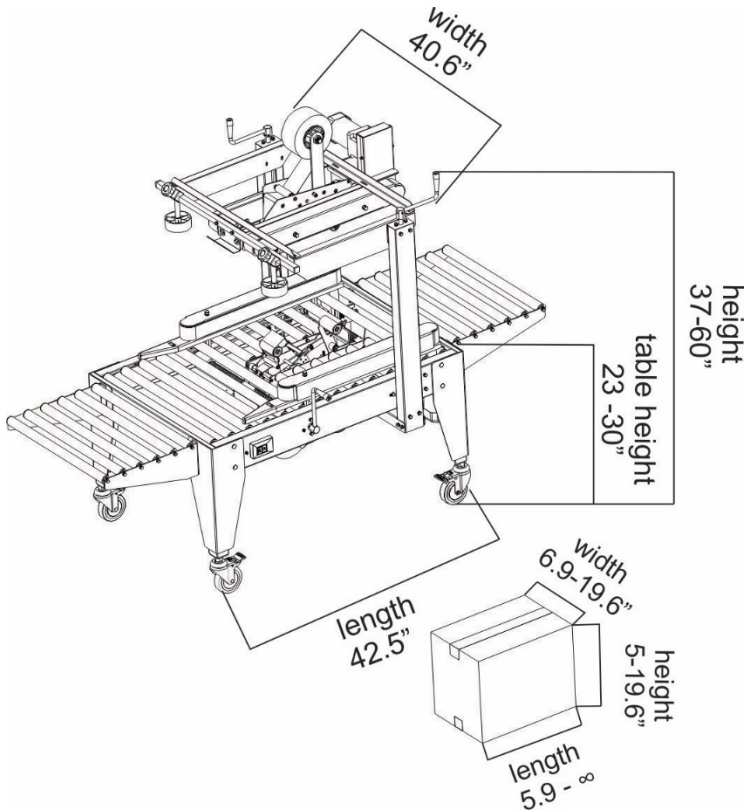

Model	MACHINE SIZE (inches)			
	length	width	height	Table height
CE-551TB-2inch Tape	42.5	30.5	37-57	Adjustable 23-30
CE-551TB-3inch Tape	42.5	30.5	37-57	Adjustable 23-30
Model	CARTON SIZE			
	length	width	height	length
CE-551TB-2inch Tape	6 - ∞	6.5 - 19.7	5 - 19.7	6 - ∞
CE-551TB-3inch Tape	6 - ∞	6.5 - 19.7	5 - 19.7	6 - ∞

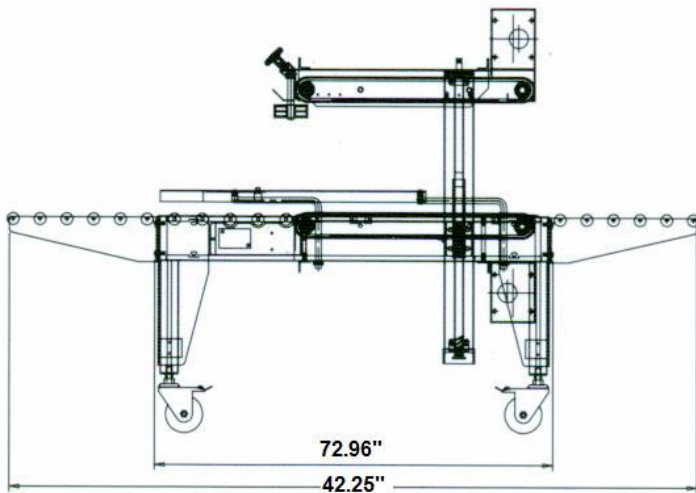
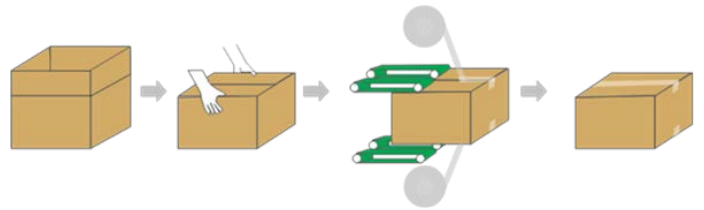

Dimension: 42 (L) x 30 (W) x 40 (H)

Power Supply: 110V / 60 Hz

Belt Speed: 75' / minute

Tape Options: 2 or 3 inch Tape Heads

Weight: 250 lbs.

1 Year Warranty



866-888-6327

sales@clevelandequipment.com

www.clevelandequipment.com