

# CE-653

## Adjustable Top and Bottom Flap Folding Sealer



Minimum Box Size:  
4.5" H x 6" L x 6" W

Maximum Box Size:  
20" H x 20" L x 20" W

The CE-653 Adjustable Top and Bottom Flap Folding Sealer allows you to form, fill and seal boxes all in one machine. The operator simply sets the new box on the T-Rail, folding the bottom minor flaps as the box is set down. The operator fills the box with product and folds down the trailing top minor flap as the box is pushed into the drive belts. The drive belts pull the box through the top and bottom folder system and through the tape heads where tape is applied to seal the top and bottom of the box. The attached T-Rail makes it easy for the operator to pack boxes.

- *Plug-in operation*
- *Dual masts with twin lead screws for stability*
- *Precise top and bottom sealing*
- *Side-mounted compression rollers for tight seals*
- *Heavy duty side-belt drives ensure square cases*
- *Adjustable leg supports*
- *Easy case-size change-over – two crank handles*
- *T-Rail System for quick and easy packaging*
- *Extended belts to pull the case through the top and bottom flap folders*



866-888-6327

[sales@clevelandequipment.com](mailto:sales@clevelandequipment.com)

[www.clevelandequipment.com](http://www.clevelandequipment.com)

# CE-653 Adjustable Top and Bottom Flap Folding Sealer

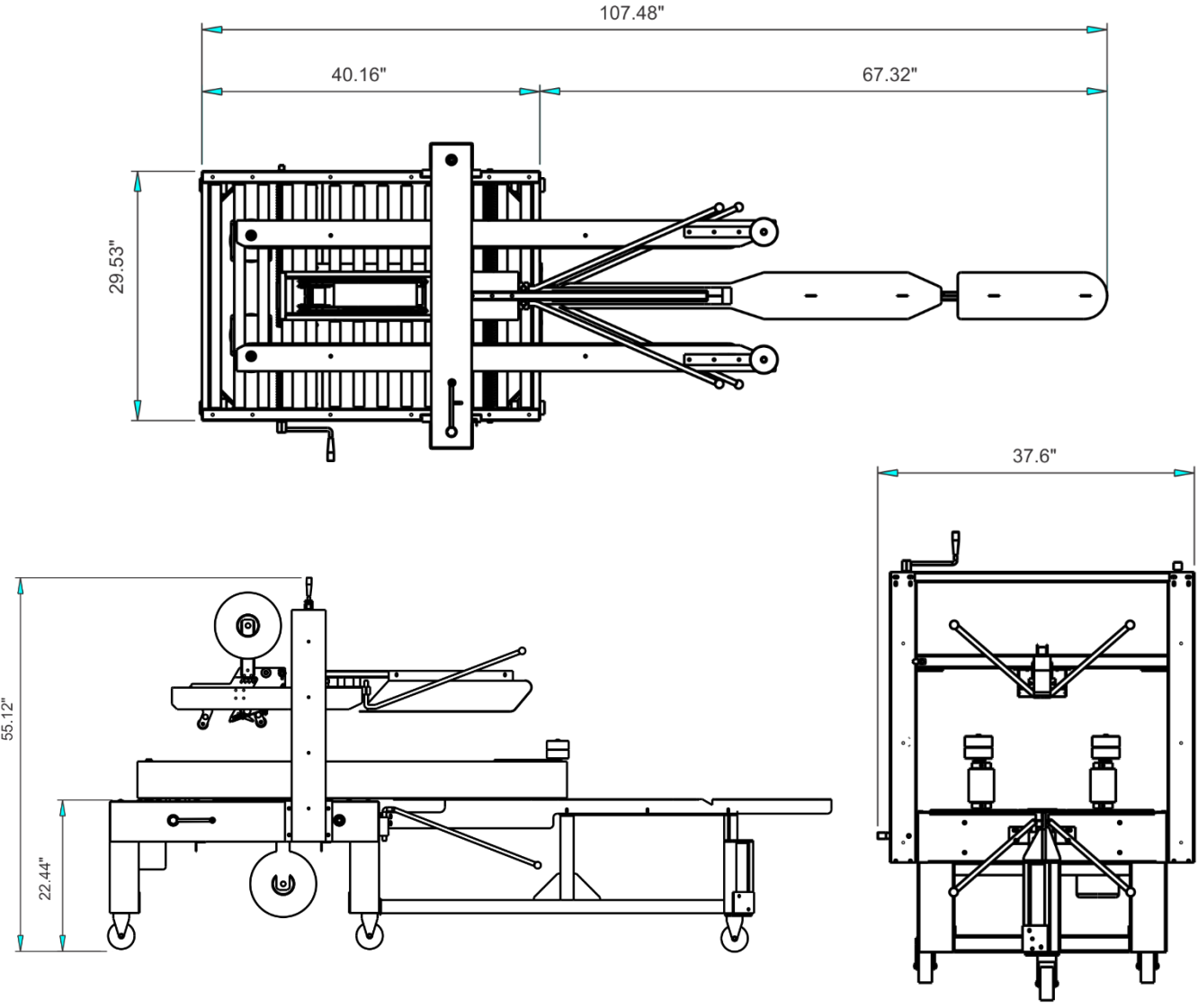

866-888-6327

sales@clevelandequipment.com    www.clevelandequipment.com