

CE-F540

LBar / Heat Tunnel Combination Wrapper



- Sealing and shrinking in one station
- Single person easy operation
- Economical for low volume production.
- Transparent cover to monitor operation.
- Standard shrink film: POV, POF, PP

The CE-F540 LBar / Heat Tunnel Combination Wrapper provides small companies an affordable way to shrink wrap their products. Due to the machine's well-engineered configuration, it takes just one operator to run it, saving time and labor costs. The CE-F540 LBar / Heat Tunnel Combination Wrapper has a loading area for placing the product inside the film before sealing it. Then the operator places the product in the sealing area. After sealing's finished, the machine blows hot air on the product to shrink the film around it. The operator can control the sealing time as well as the temperature of the air.

This shrink wrapper is suitable for POV, POF and PVC shrink films. It requires 220V power and can accommodate a maximum package size of 21" x 15" x 11".



Sealing bar



Board for separating film.



Improved needle wheel



866-888-6327

sales@clevelandequipment.com

www.clevelandequipment.com

CE-F540

LBar / Heat Tunnel Combination Wrapper

Power supply	220-240V / 50-60Hz
Power	3.8KW
Max. packing size	21"L x 15"W x 11"H 550mm x 400mm x 300mm
Max. sealing size	21"L x 15"W
Working efficiency	150-250 pcs/h.
Machine size	54"L x 26.5"W x 45.75"H 1400mm x 730mm x 1450mm
Machine weight	283 lbs (128kg)



Fan

- Sealing and shrinking 2 in 1 step, easy to operate with a compact space requirement.
- Accepts a variety of shrink film such as PVC, POF etc.
- The sealing blade is made of non-stick high temperature-proof alloy without carbonization and smoking when packaging. The sealing time is easy to adjust based on the thickness of the film.
- Stainless steel heating tube with a heat dissipation surface and quick preheat Increasing temperature. Continuous Operation for long periods of time without overheating.
- Automatic convey function unloads the product automatically by the conveying belt and the with adjustable transport time.

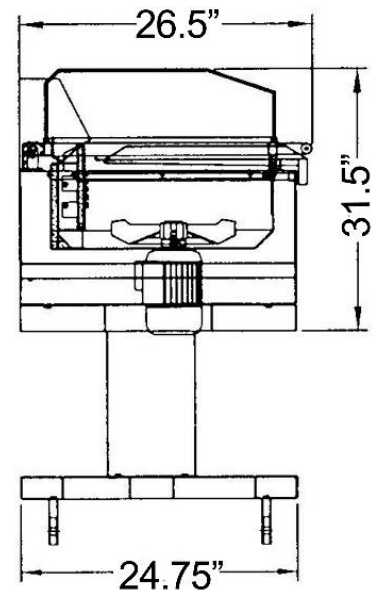
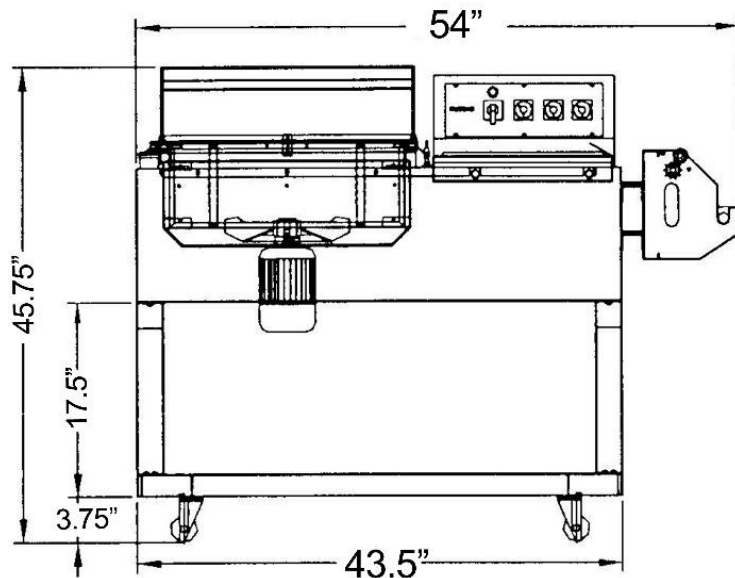

866-888-6327

sales@clevelandequipment.com

www.clevelandequipment.com