



## CE-F400 LBar / Heat Tunnel Combination

- Sealing and shrinking in one station
- Single person easy operation
- Economical for low volume production.
- Standard shrink film: POV, POF, PP

The CE-F400 LBar / Heat Tunnel Combination Wrapper provides small companies an affordable way to shrink wrap their products. Due to the machine's efficient design and easy operation, it takes just one operator to run it, saving time and labor costs. The CE-F400 LBar / Heat Tunnel Combination Wrapper achieves sealing, cutting and shrinking on the same machine. Separated components for Seal-cut and shrinking functions allow for use together or individually. With a compact structure designed for small volume the machine is easily transported.

Shrinking chamber has inner heating cycle which ensures even heating to achieve a uniform shrinkage. Adjustable film frame and foldable conveyor guide for work efficiency.

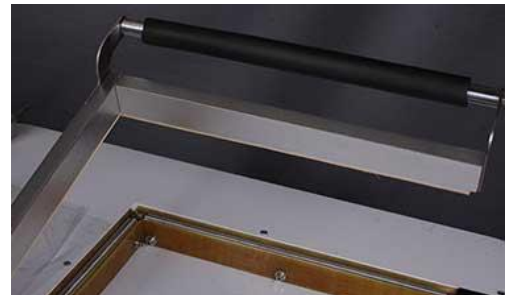

Sealing bar



Teflon conveyor belt



866-888-6327

[sales@clevelandequipment.com](mailto:sales@clevelandequipment.com)

[www.clevelandequipment.com](http://www.clevelandequipment.com)

# CE-F400

## LBar / Heat Tunnel Combination Wrapper

|                       |  |
|-----------------------|--|
| Model                 | CE-F400  |
| Power supply          | AC220-240V/50-60Hz                                     |
| Seal-cut time         | 0-3sec   |
| Shrinking time        | 0-60sec  |
| Capacity              | 300-600time/h  |
| Thickness of the film | 0.015-0.08mm   |
| Power                 | 4.5KW  |
| Max. packing size     | 400mm L x 400mm W<br>15.75" x 15.75"                   |
| Machine size          | 1050mm L x 740mm W x 1340mm H<br>41" L x 29" W x 53" H |
| Machine weight        | 370 lbs (168kgs)                                       |

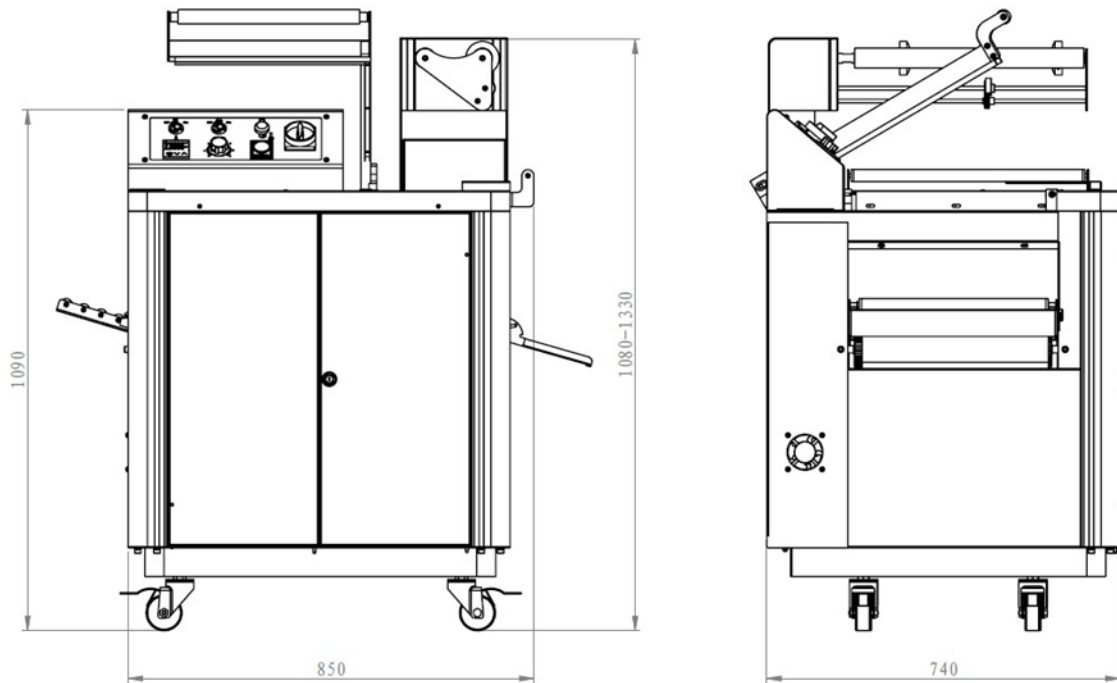

**866-888-6327**

[sales@clevelandequipment.com](mailto:sales@clevelandequipment.com)

[www.clevelandequipment.com](http://www.clevelandequipment.com)