

CE-D1Z **Material Conveyor**

- Infeed Supply Hopper Volume: 100L
- Dispensing height 69"
- Lifting speed 2.5 - 5 cubic meter/hour
- Power 550w Voltage 220v
- Size 124.6" L x 26" W x 89" H
(3165x650x2260mm)
- Specification: The parts contacted with food are food grade plastic

The CE-D1Z conveyor is appropriate for vertical lifting of granule material, for example, corn, grain, plastic and granule applications, and so forth. The container is moved by the conveyor chains. Utilized for vertical dispensing of granules or small piece material. the CE-D1Z can handle large amounts lifting to 69" max. All parts contacted with food are food grade plastic.

CE-D1Z Material Conveyor

- Vibrator amplitude Max: 4mm (Dual Vibrator, Max voltage 220V)
- Overload protection for the motor, chain and hopper with torque limiter and electrical time relay.
- Automatic Shut Off when back cover is opened while running in order to prevent accidents
- Plexiglass back cover can see the operation of hopper clearly
- Infeed Supply Hopper Volume: 100L
- Bucket volume: 1.8L
- Bucket size: 16.5" L x 5.5" W x 2.76"H
- Conveying volume: 3~6m³/h
- Electrical power: 0.75KW (50Hz, 2.0A)
- Voltage: 220V,50/60HZ

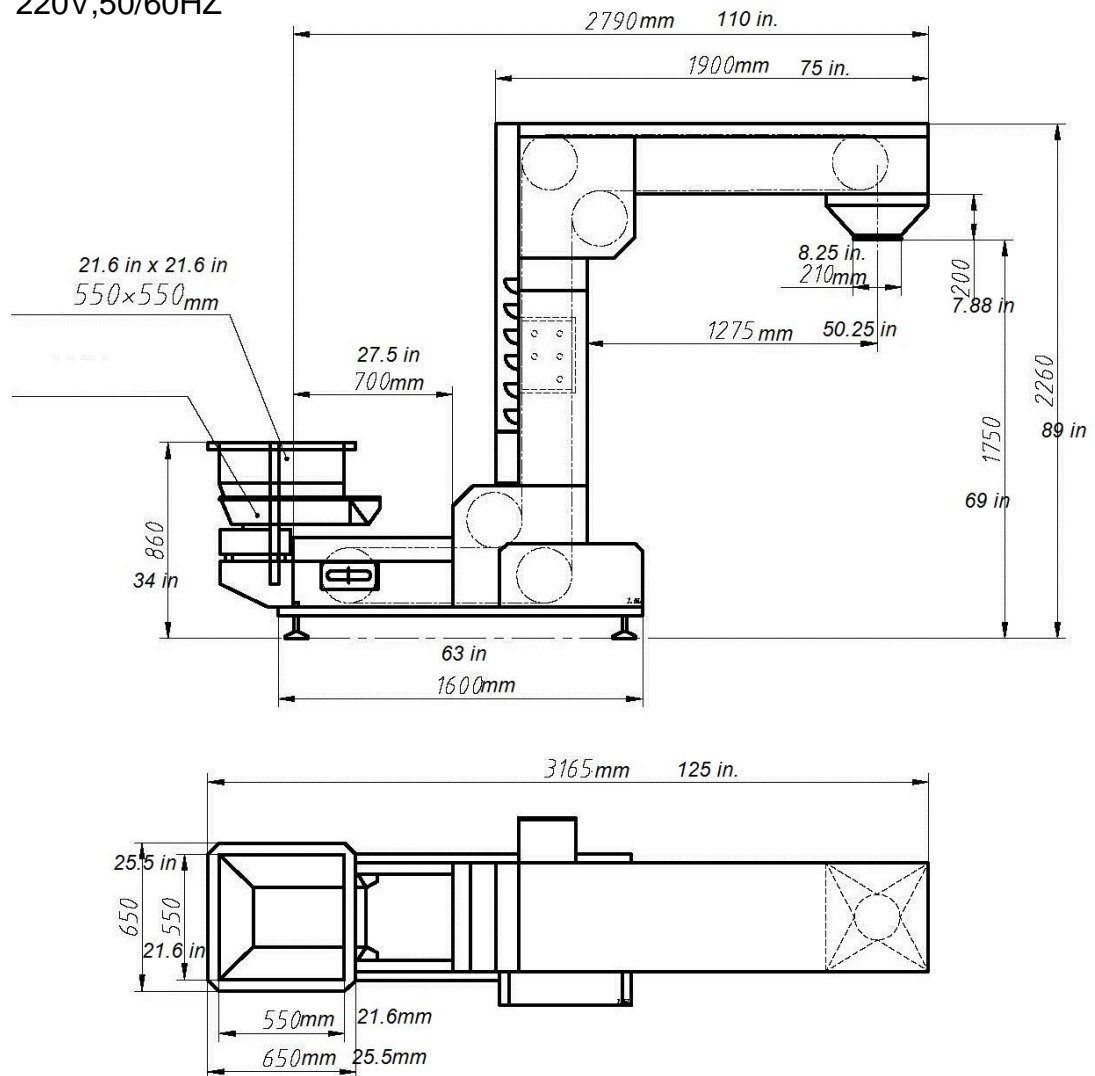

866-888-6327

sales@clevelandequipment.com

www.clevelandequipment.com