Fully Pneumatic Piston Filling Machine

SGP Series



ATTENTION:

Machine must be completely torn down, cleaned, sanitized, and lubricated with H3 food grade lubricant prior to use. A recommended lubricant has been provided.

This machine requires an air compressor.
We would recommend a 20+ gallon compressor.
The air requirements for this machine are 5cfm@90psi.

Instructions

(Please read it carefully before using the machine!)

Table of Contents

Chapter 1 Overview.....	2
1-1 Overview.....	2
1-2 Features	2
1-3 Parameters.....	2
1-4 Working Principle	2
1-5 Working Process	2
1-6 Available Range	3
1-7 Introduction to Parts and Specifications.....	3
Chapter 2 Operation Instruction	4
2-1 Preparation.....	4
2-2 Operation Method.....	4
2-3 Fault Analysis and Troubleshooting	5
2-4 Safety Instruction.....	6

Chapter 1 Overview

1-1 Overview

The SGP Series fully pneumatic filling machines are newly designed for paste, cream and liquid filling, and its filling amount can be adjusted as required based on the specified range, featuring high stability, reliability and filling accuracy.

1-2 Features

1. All surface materials of this machine are crafted of 316 stainless steel, which features high acid-resistant and corrosion-resistant properties, as well as presenting a high quality finish.
2. You can operate it safely and easily, and adjusting the filling amount can be performed within the range as required with high accuracy.
3. Its reasonable layout enables you to simply disassemble, safely operate, and easily clean the filler.
4. Due to a total lack of electrical components, this filler can be used safely in a wide array of hazardous or moist environments.

1-3 Parameters

Item		SGP-120
Available range		Paste, Cream, Liquid
Filling range	Cream	10-120ml
	Liquid	-
Filling accuracy	Cream	±2%
	Liquid	±1%
Working air pressure		0.4-0.5MPa
Throughput		0-30 bottle/minute
Outline (length x width x height)		---
Net weight		---

Note: For this series of machine, the maximum liquid amount to be filled should be less than 5%-10% of the cream amount.

1-4 Working Principle

The cylinder runs in reciprocating and linear manners to drive the piston and generate suction and thrust as to draw and push your product.

1-5 Working Process

Open the inlet valve, adjust the working air pressure and select the working status (automatic or semiautomatic). During the operation, the rotary cylinder linkage is turned (opens a path towards the front while sealing towards the top), the fill head cylinder moves upwards to open the discharge valve, the piston cylinder actuates to move the piston forward, which dispenses material for filling (the speed can be adjusted by "Behind" valve); after that, the fill head cylinder moves downwards to close the discharge valve to prevent dripping, the rotary cylinder linkage returns (seals towards the front while opening a path towards the top), the piston cylinder actuates to move the piston rearward, which pulls new product into the chamber for the next filling (the speed can be adjusted by "Front" valve). Thus the operation is accomplished.

1-6 Available Range

It is ideal for specialized industries such as food, daily chemistry, pesticide and medication.

1-7 Introduction to Parts and Specifications

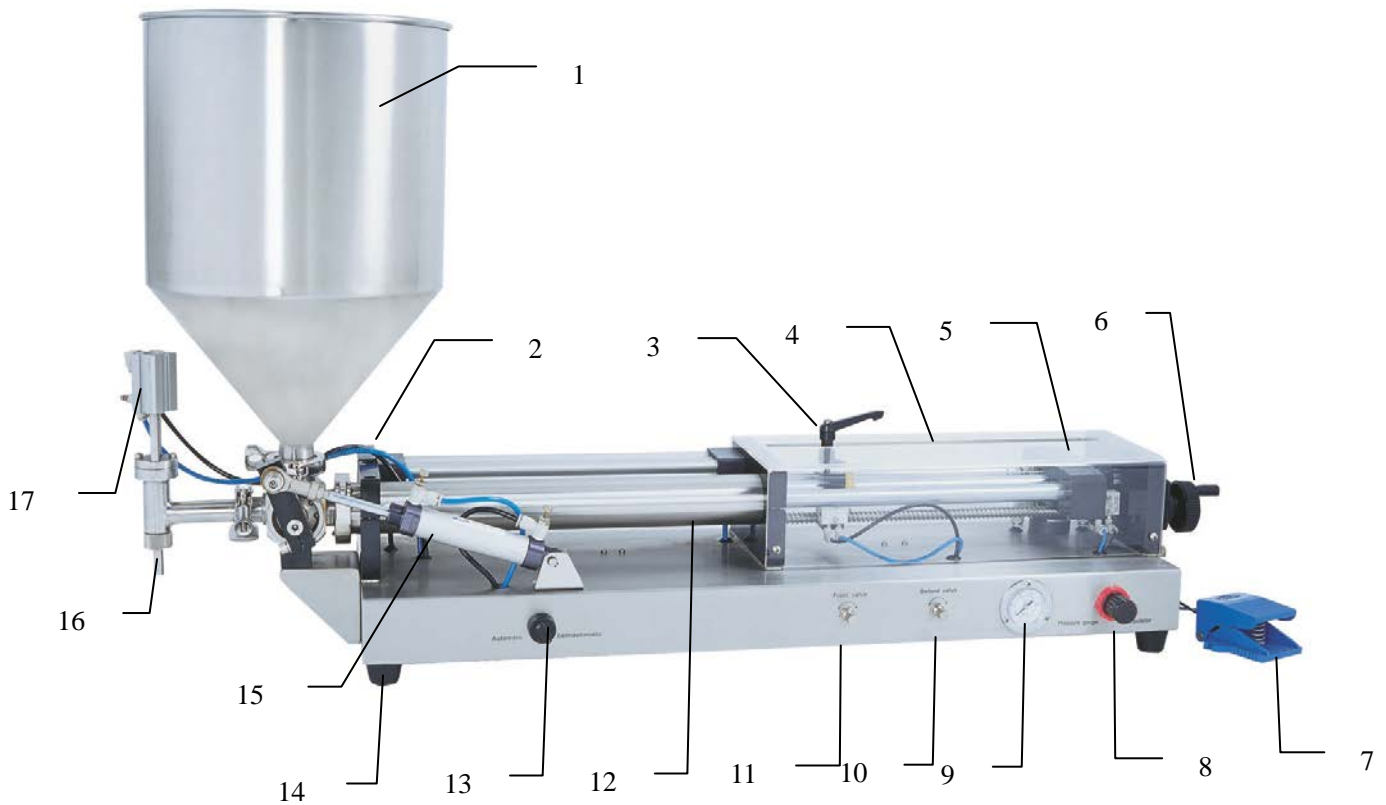

- | | |
|---------------------------------|------------------------------------|
| 1. Hopper | 10. Behind valve |
| 2. Main piston cylinder | 11. Front valve |
| 3. Adjustable handle/sensor | 12. Product chamber |
| 4. Protective covering | 13. Automatic/Semiautomatic switch |
| 5. Active slide | 14. Under-chassis |
| 6. Rotating hand wheel | 15. Rotary assembly cylinder |
| 7. Foot switch | 16. Fill head nozzle |
| 8. Air pressure regulation knob | 17. Fill head cylinder |
| 9. Gas pressure meter | |

Chapter 2 Operation Instruction

2-1 Preparation

1. Precautions

- (1) The inlet air pressure should be 0.5-0.8Mpa and the working air pressure should be 0.4-0.5 Mpa.
- (2) Keep all appendages clear of moving parts during operation.

2. Filling amount troubleshooting

Adjust the filling amount as follows:

- (1) Put materials to be filled into the hopper.
- (2) Prepare measuring cup or scale to identify quantities desired.
- (3) Turn the hand wheel to show the required filling amount value on the position display.
- (4) Check to ensure that the operation switch is set to Semiautomatic, use the foot switch to control the cycle, measure the obtained materials to see whether it is in the desired range. If not, proceed with the following steps.
 - A Loosen the adjustable handle on the volume adjustment block.
 - B Loosen the fixed screw of the position display near to the handle and turn the handle clockwise or counterclockwise.
 - C Repeat step 4, use a measuring cup or bottle to measure the materials and adjust the handwheel until the obtained result is in the desired range.
 - D Finally fasten the adjustable handle on the adjustment block and fasten the fixed screw of the display to avoid parts shift and influence of the filling accuracy.

2-2 Operation Method

- (1) Connect the air source and slide the air inlet collar towards the machine.
- (2) Check whether the air pressure meter is in the specified range. If not, draw the air pressure knob outwards to unlock, rotate the pressure regulator knob until the pressure is in the specified range (0.4-0.5Mpa) and push the knob back in to lock.
- (3) Use the switch to set the filler to semiautomatic mode, controlling the filler through the foot pedal.
- (4) To make an adjustment, loosen the adjustable handle on the adjustment block, rotate the handwheel, read the value on the position display and tighten the handle.
- (5) Adjust the front valve (for adjusting drawing speed) and behind valve (for adjusting filling speed) as shown in Figure 1 to get reasonable drawing and filling speed.

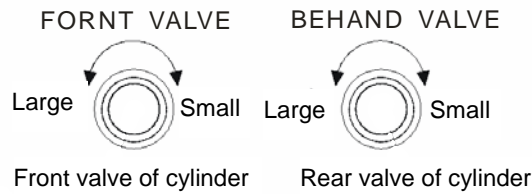

Figure 1

- (6) Fill the hopper with product and prepare the container to be filled.
- (7) Proceed with filling and control the operation with the foot switch. Step on the foot switch once to cycle a complete filling operation. You can adjust and use automatic level if you are proficient enough to use the filler on automatic filling.

2-3 Fault Analysis and Troubleshooting

Symptom	Analysis	Troubleshooting
The machine fails	Check whether the air pressure collar is open	Open it
	Check whether the air source is open (compressor)	Open it
	Check whether the value on air pressure meter is within correct range	Adjust it to 0.4-0.5MPa
	Check whether there is leakage on the pipe joint or damage on air lines	Insert the pipe again or replace air lines
	Check whether air amount is adjusted to the minimum (tightened too far) via the front valve and behind valve	Adjust the valves
	Check whether the air amount on the fill head cylinder is adjusted to the minimum (tightened too far)	Adjust the valve to the working status
	Check cleanliness of machine. Product may be hardened, tacky, or sticky, causing rotary assembly or main piston to be stuck	Clean the machine
Filling is not even	Check for air leakage in all air line connectors	Fasten each joint
	Check for leakage in the main piston cylinder	Replace the piston lock ring
	Check product level in hopper	Add materials
	Check for correct speeds during pushing and drawing process	Adjust the front valve and behind valve to the stable status
	Check whether the material viscosity is even	Agitate or mix product

2-4 Safety Instruction

1. You can use soap and warm water to clean the machine. Fill hopper with cleaning agent and water; cycle until discharge is clear of any product; fill hopper with clean water and cycle until water is clear.
2. Never use sharp tool on any parts surface when cleaning the internal parts and install the parts when they are dry.
3. Use lubricant for all moving parts.
4. Check the lock rings of all parts and replace damaged rings.
5. Check whether there is damage or leakage on the air lines.
6. Fasten screws of all parts.
7. Never clean the machine surface via harsh or abrasive cleaners to protect the air control component.
8. Never cycle the machine without a product for more than a few cycles.
9. Never put hard materials into the air-operated component and hopper.
10. Put the machine flatly in a dry place with little dust and leave enough space for the movement of the machine cycle.
11. Use the machine in air-current environment when volatile liquid is to be filled.
12. Body or materials should be far away from moving parts and our factory takes no responsibility for any machinery and human injury due to it.
13. Cut off the air source when repairing/disassembling/replacing parts/cleaning.
14. Never use an organic flux to clean the machine, such as gasoline, acetone, benzene, xylene, banana oil and sodium hypochlorite.

SGP-120 Piston Filler

Seal Listing

Machine comes standard with Buna (Nitrile) O-Rings

Viton Available as an Upgrade

Best type of seal for alcohol based products: Kalrez

Kalrez available at McMaster Carr

Description	Metric Measurement	American Standard (ASE)
Piston	4mm x 21mm	Dash 211
Rotary	3.5mm x 28mm	Dash 216
Fill Head (Several Pieces)		
Nozzle	3mm x 18mm	Dash 116
Plunger	3mm x 12mm	Dash 112
Shaft	3mm x 5.5mm	Dash 202
Upper, Outer	2mm x 18mm	Dash 018
Upper, Inner	2.5mm x 13mm	Dash 113
Rotary to chamber gasket	1.5 inch Tri-Clamp	
Rotary to hopper gasket	1.5 inch Tri-Clamp	
Rotary to fill head gasket	0.75 inch Tri-Clamp	
Rotary flange o-rings	2mm x 26mm	Dash 121

Cleveland Equipment S Series filler breakdown

How to break down the rotary

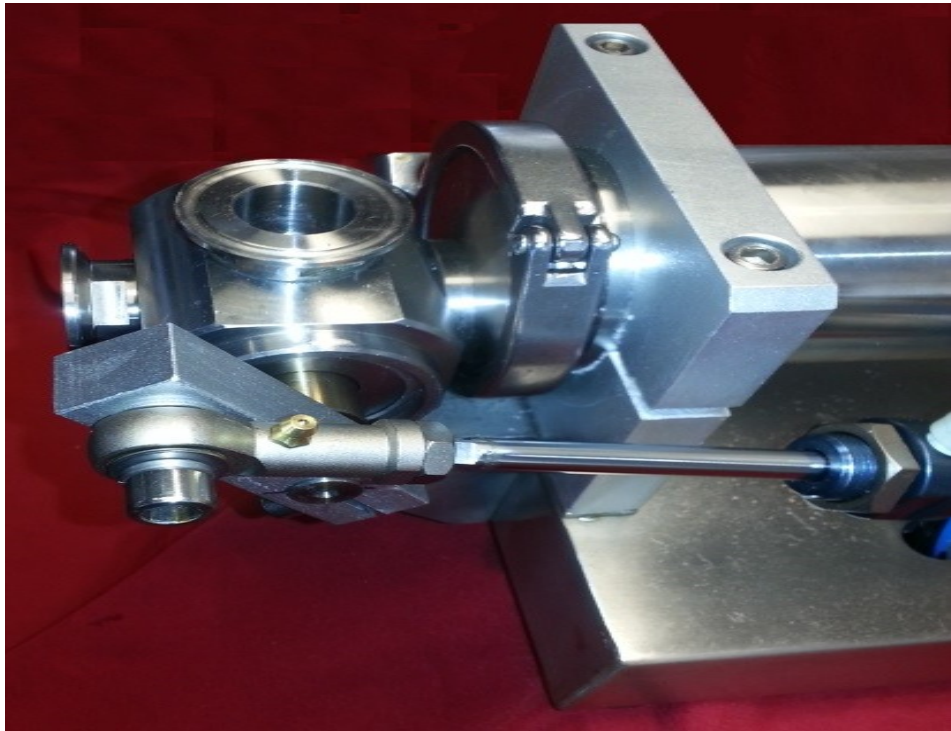

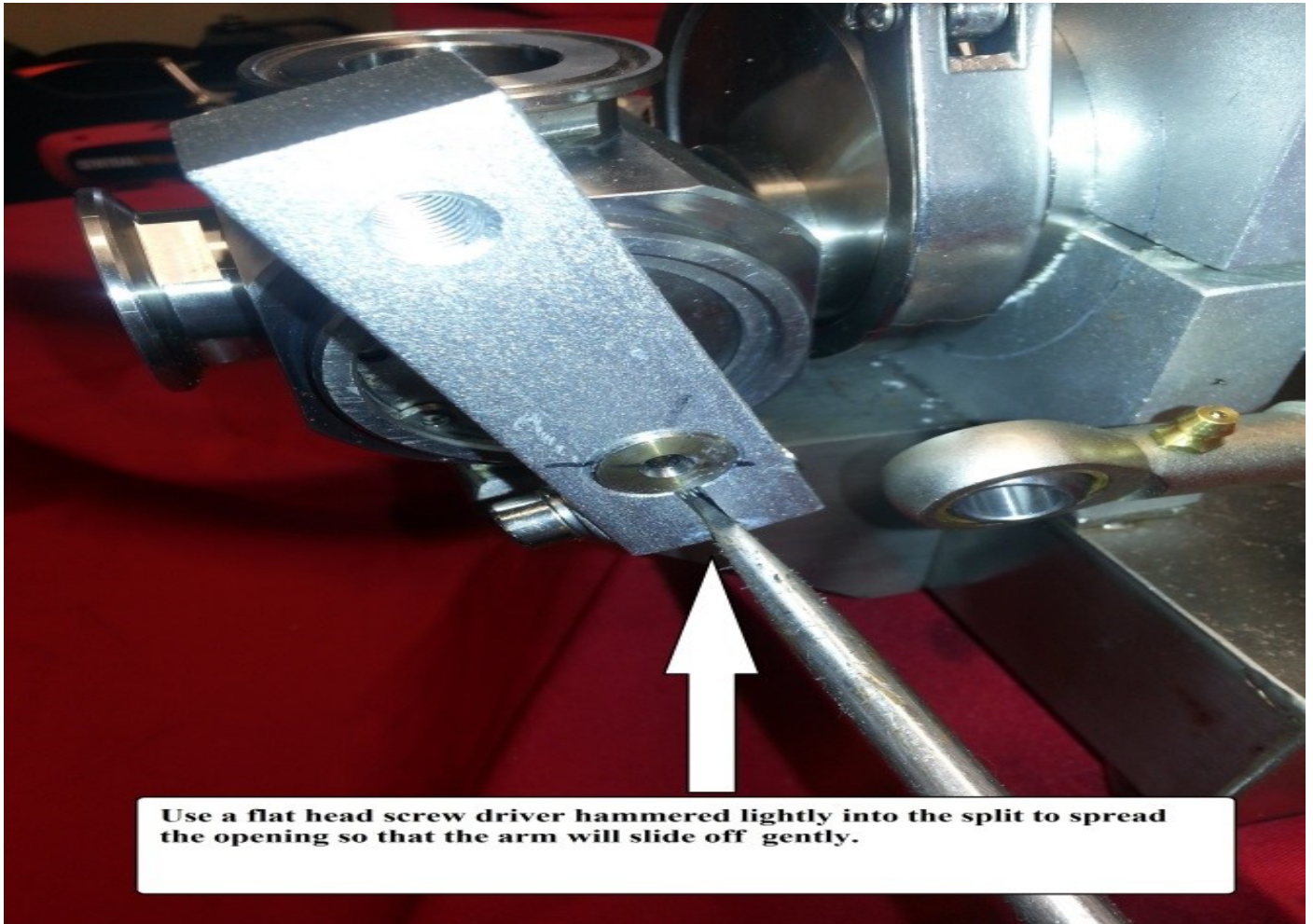
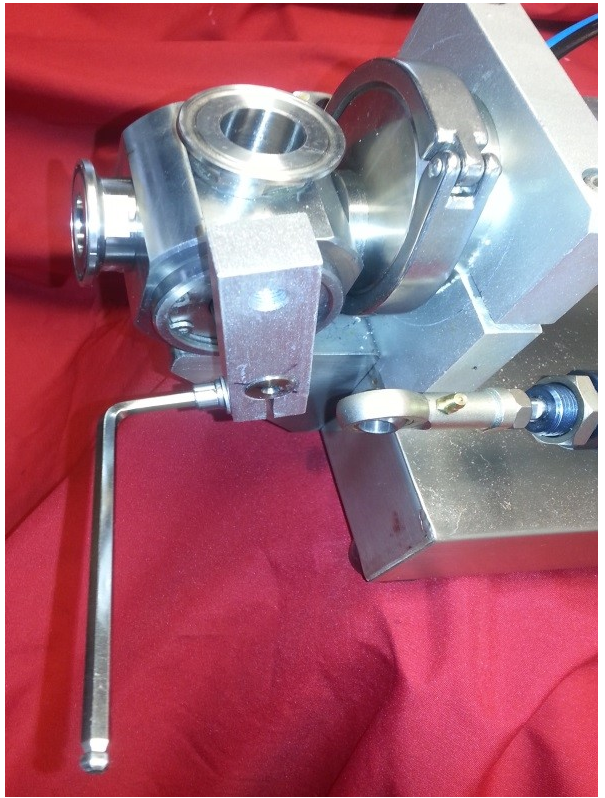
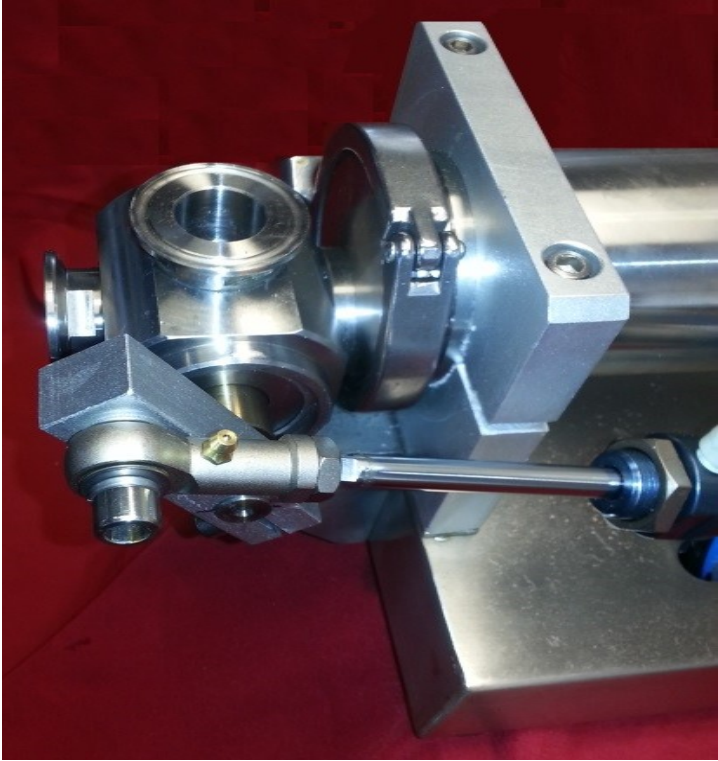

Use a flat head screw driver hammered lightly into the split to spread the opening so that the arm will slide off gently.

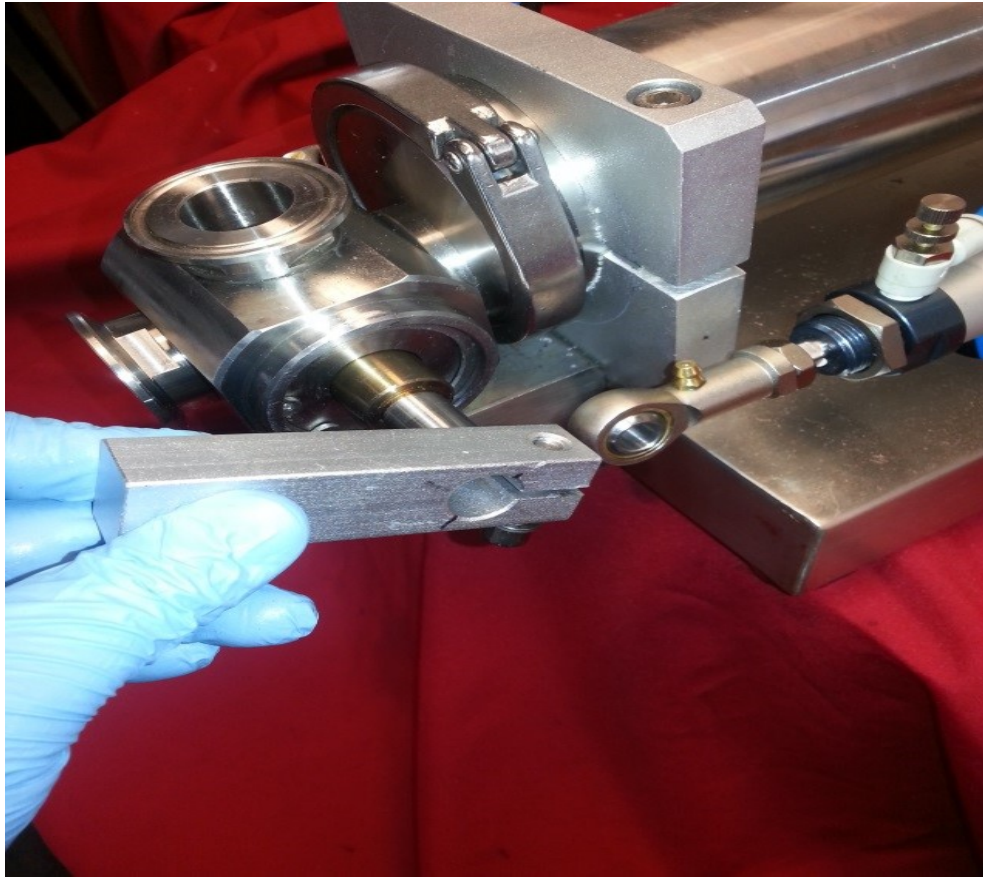

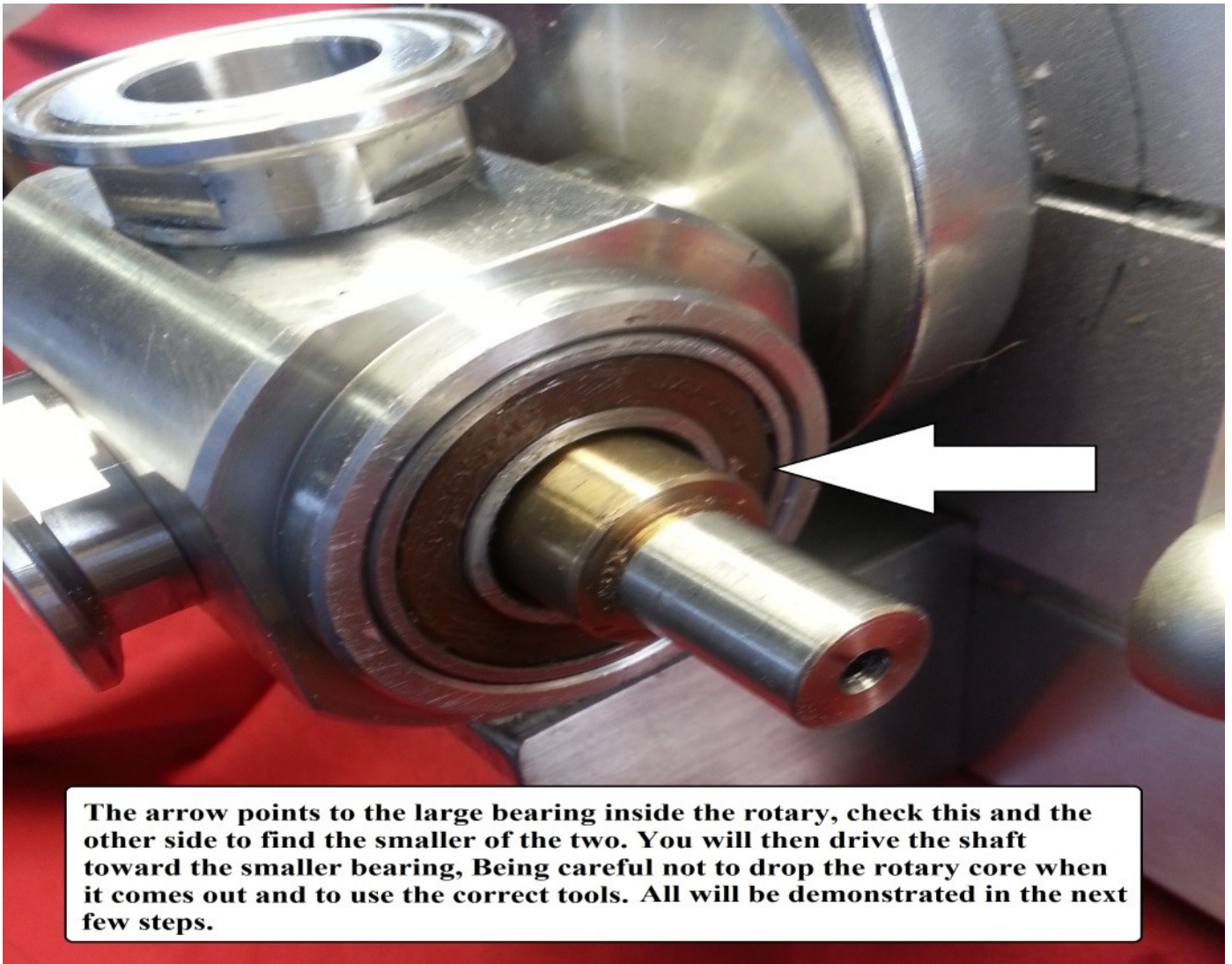

The arrow points to the large bearing inside the rotary, check this and the other side to find the smaller of the two. You will then drive the shaft toward the smaller bearing, Being careful not to drop the rotary core when it comes out and to use the correct tools. All will be demonstrated in the next few steps.

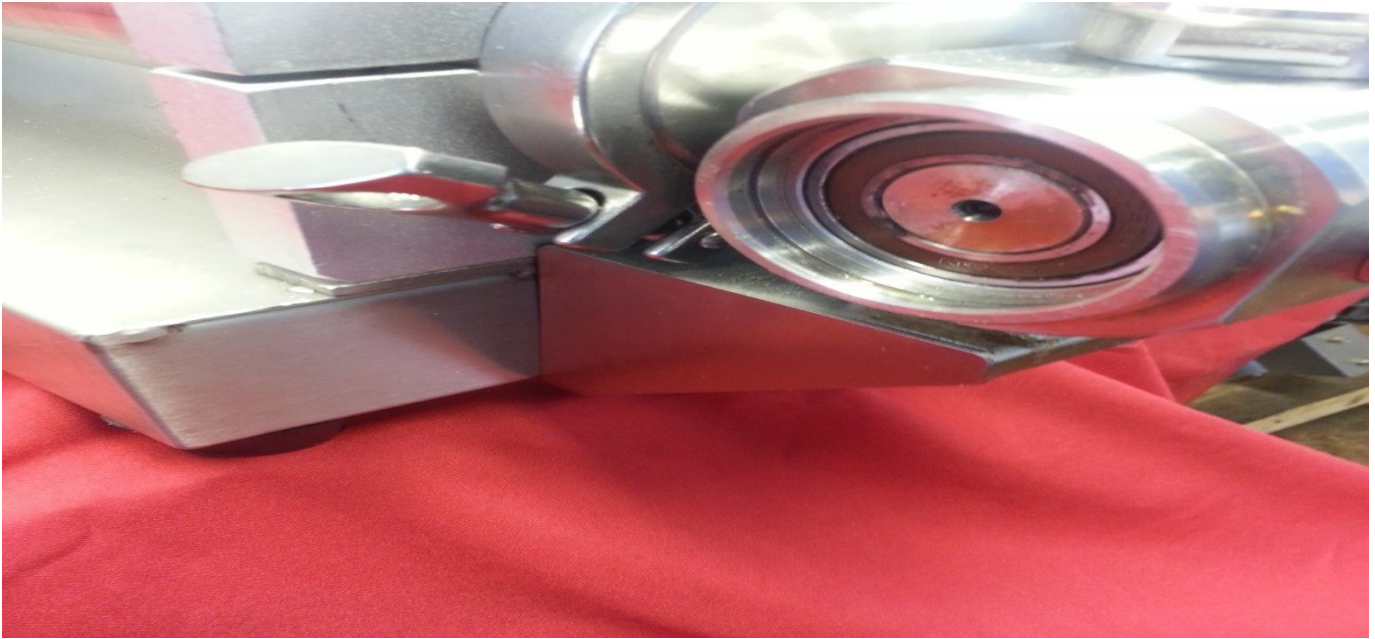

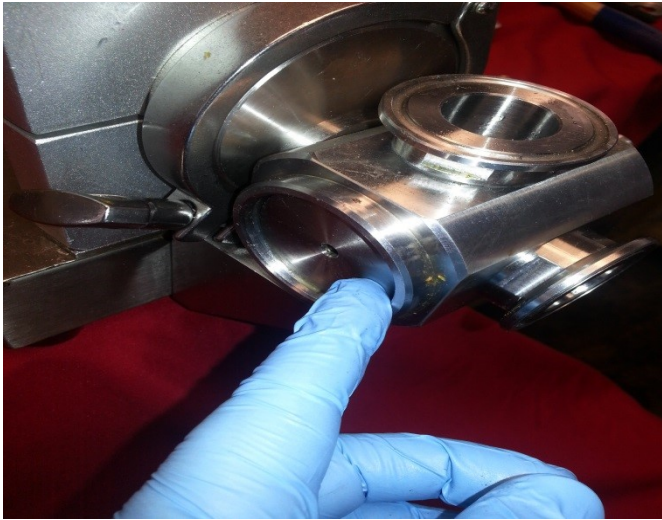
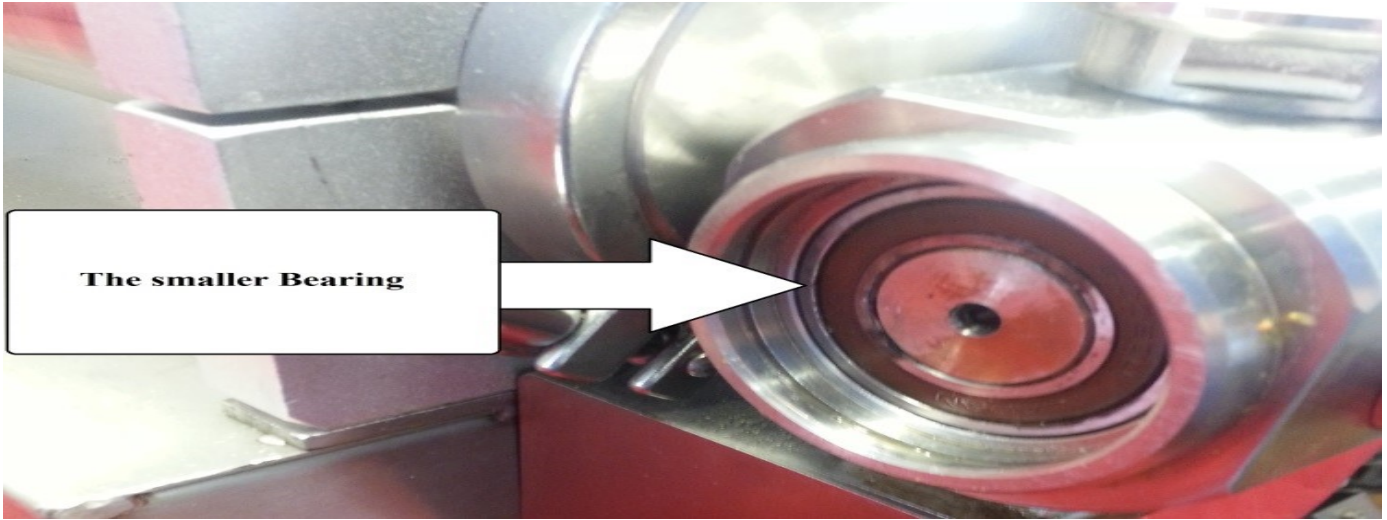

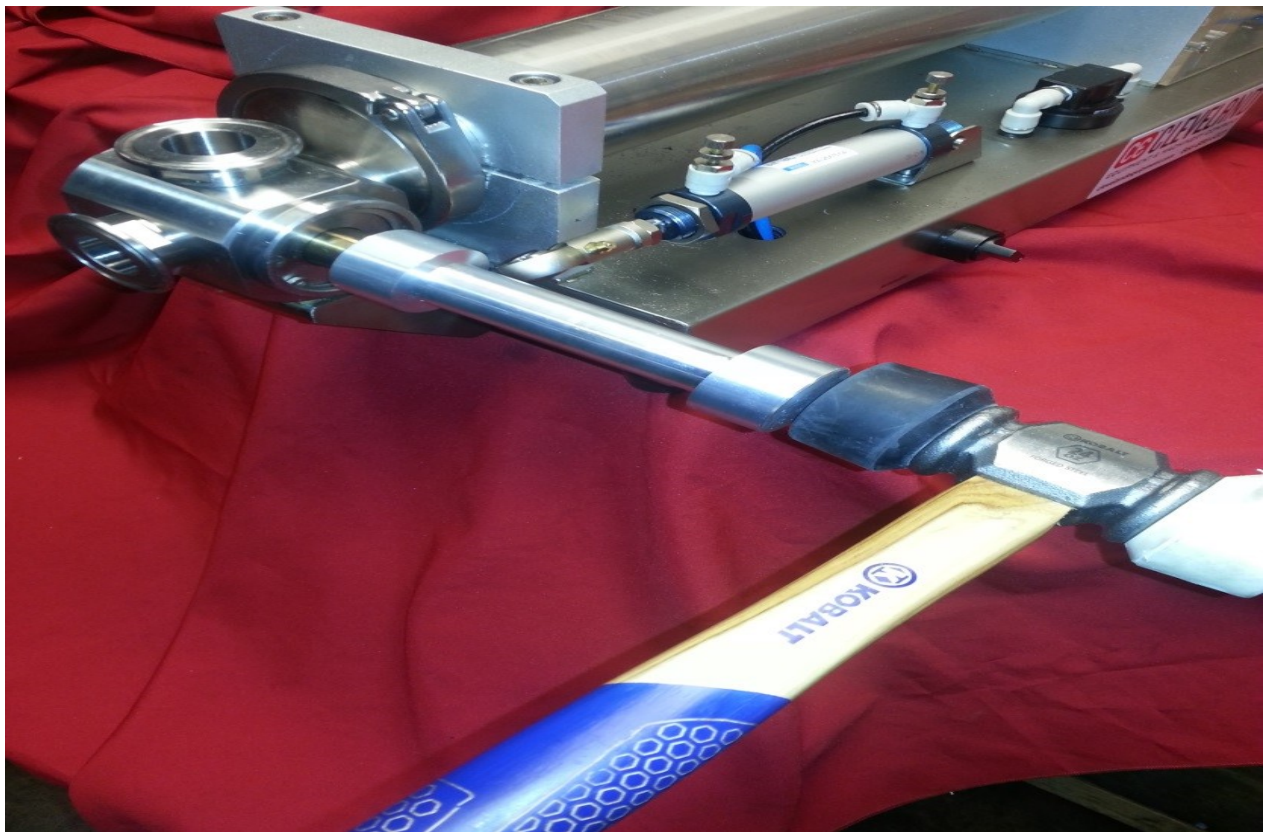
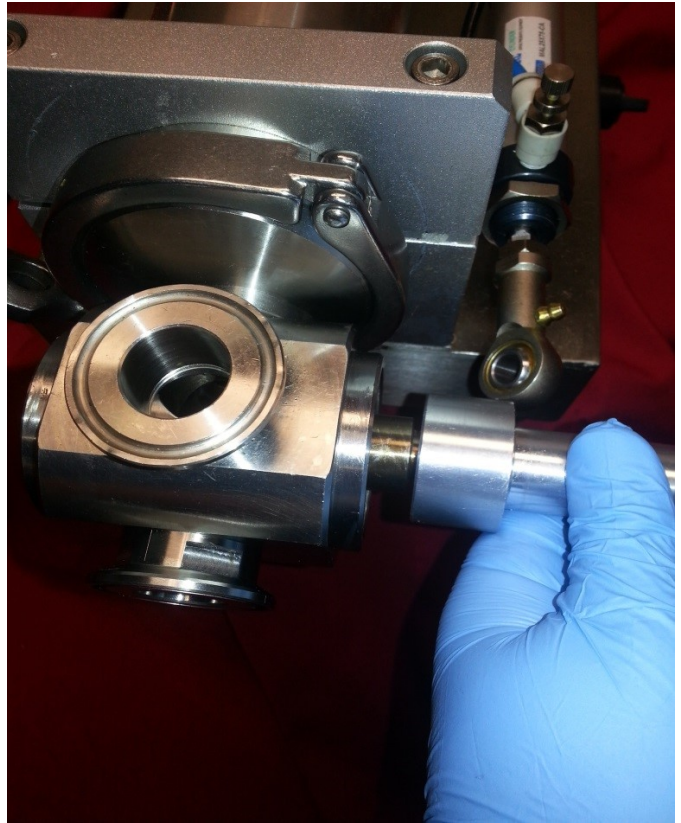
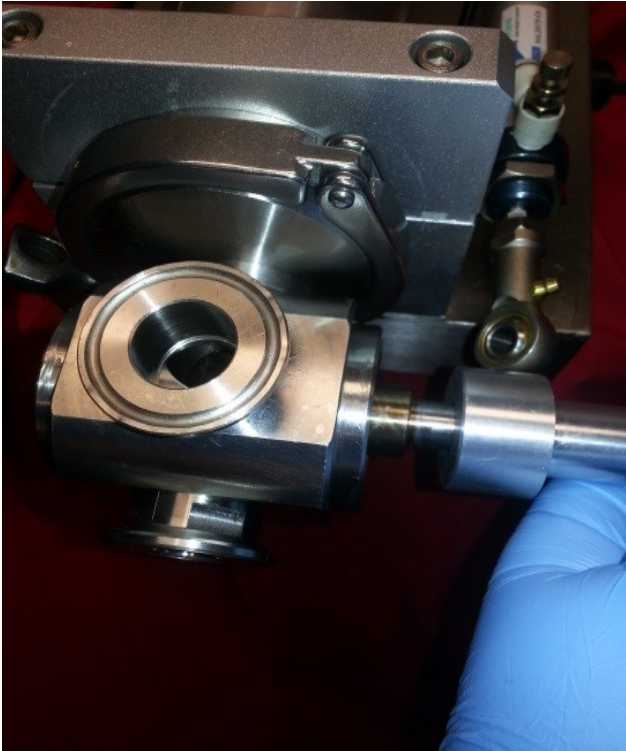

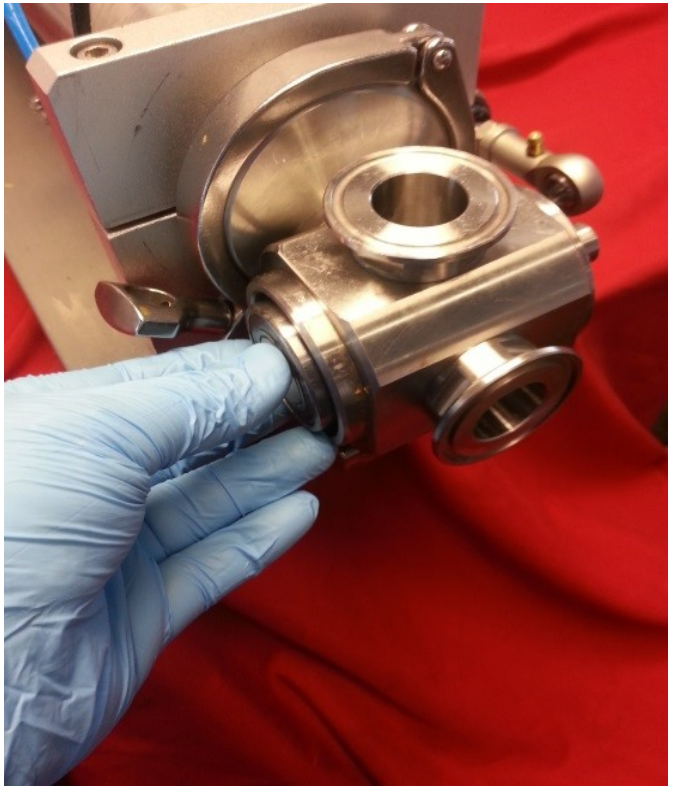
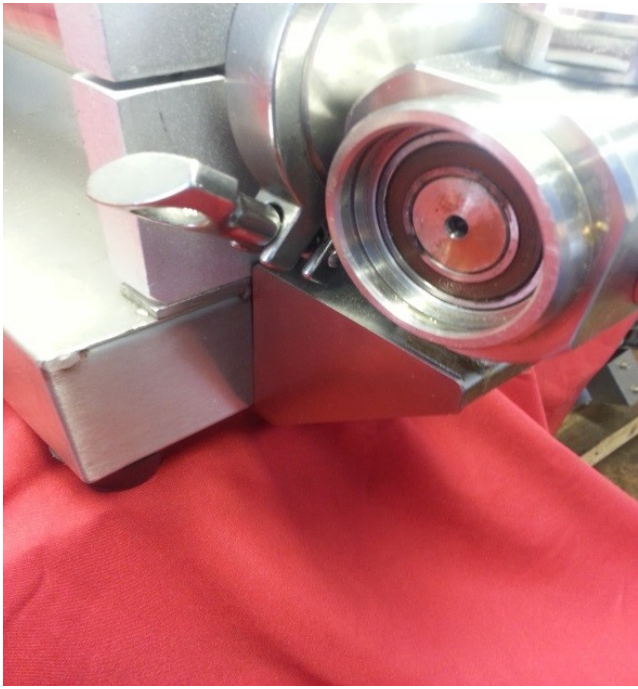

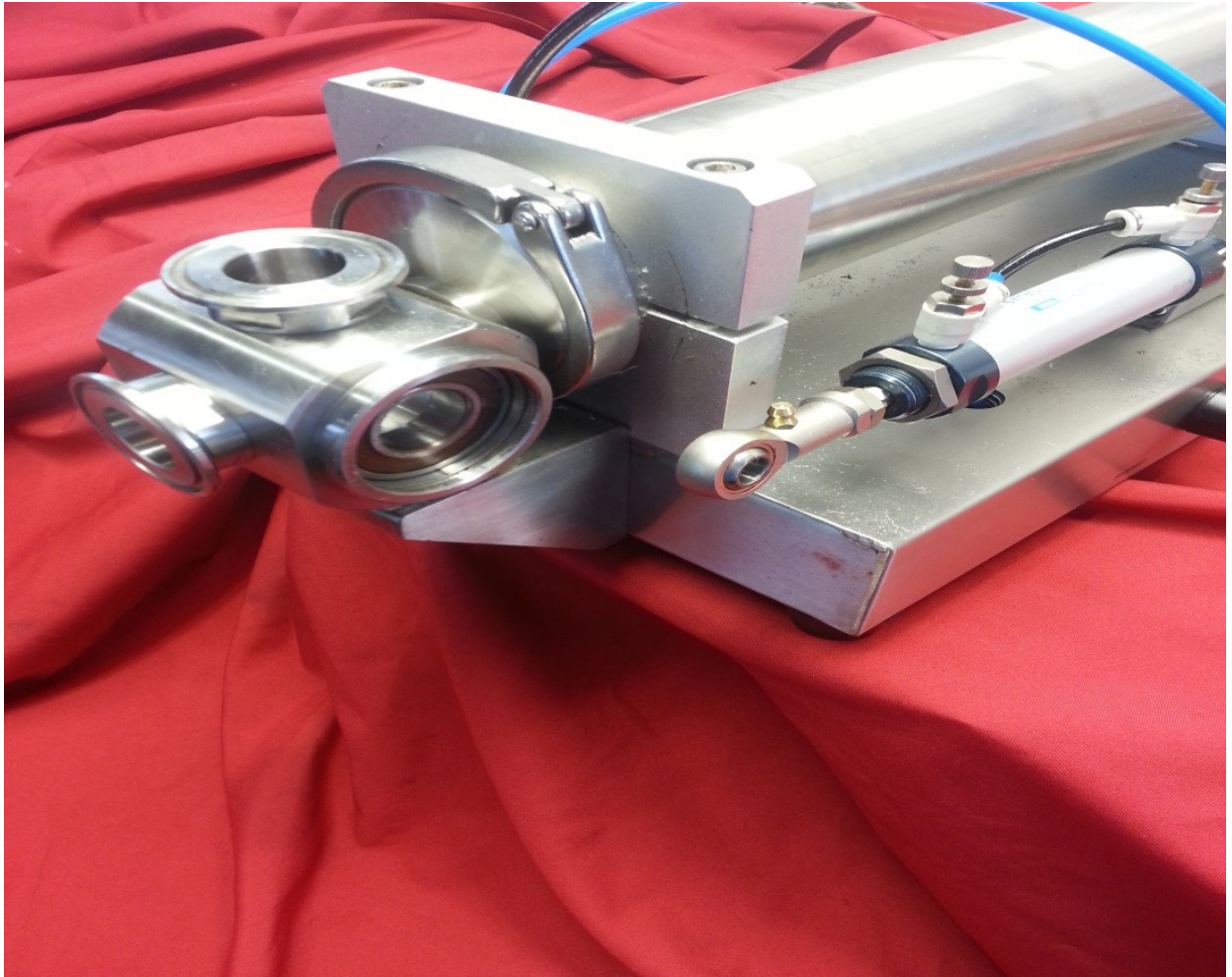

Cylinder removal and piston check

to put the cylinder back together please reverse these steps

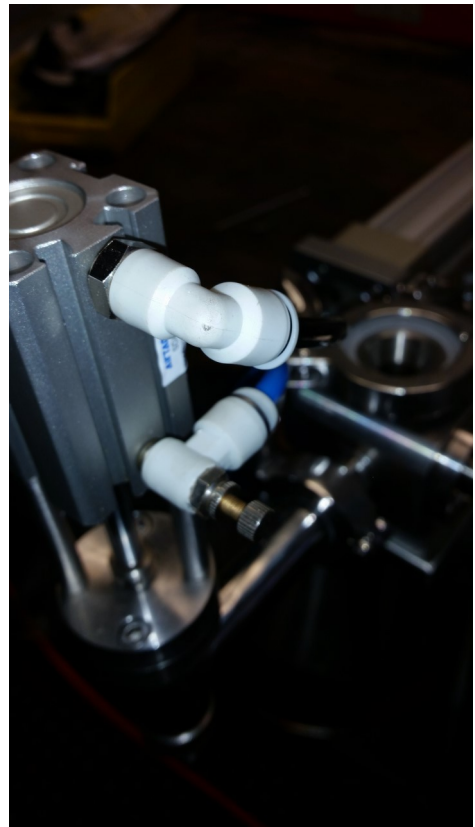
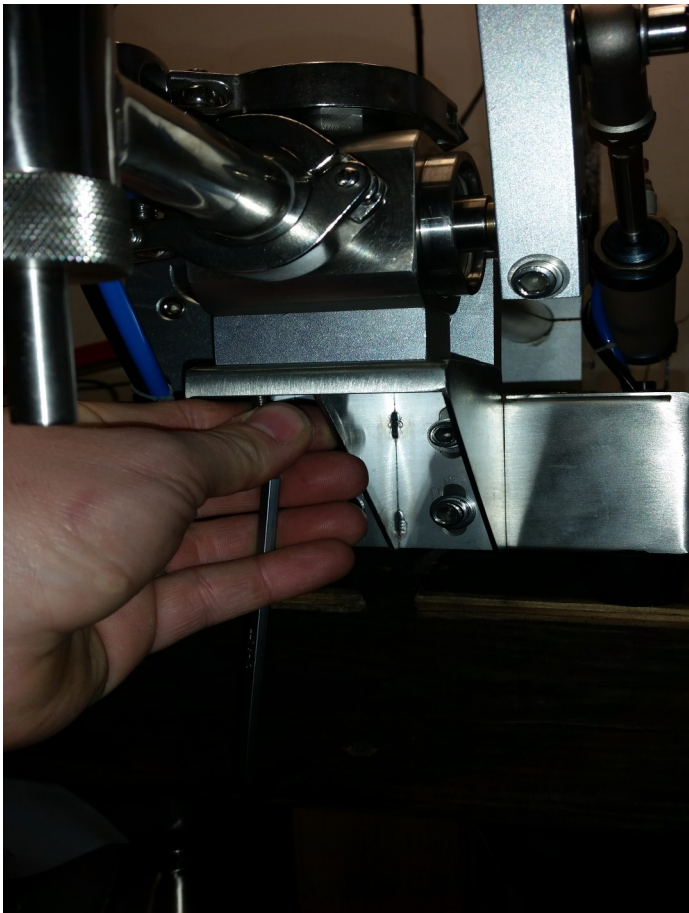
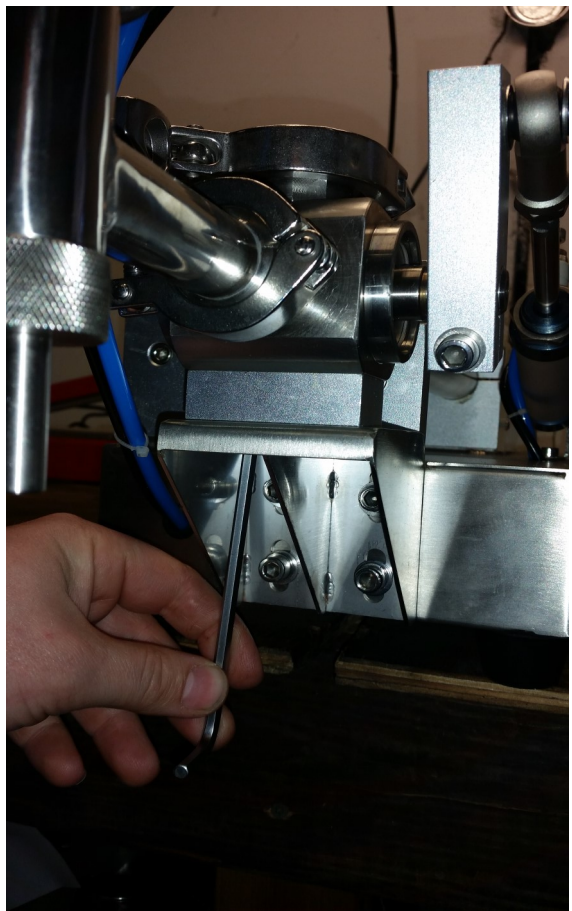
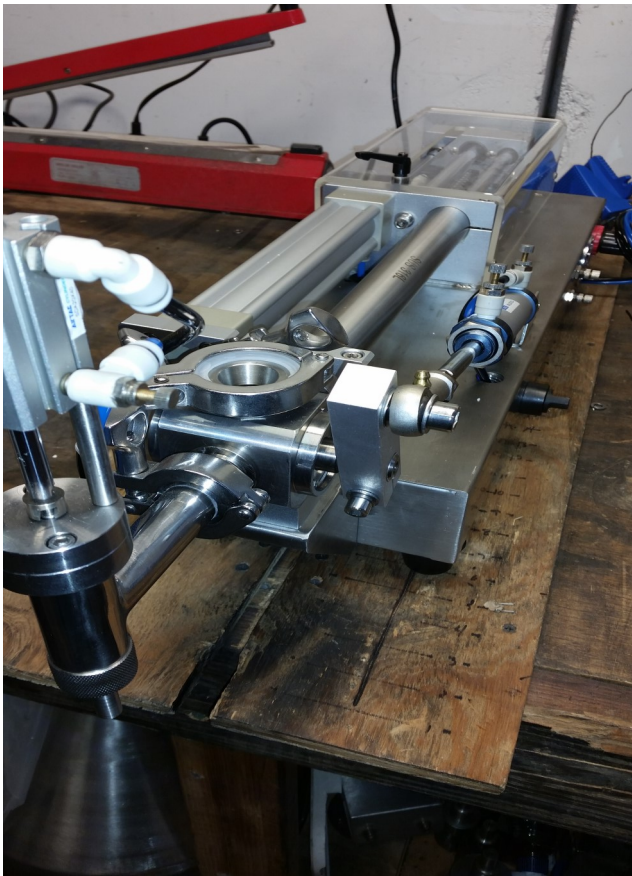

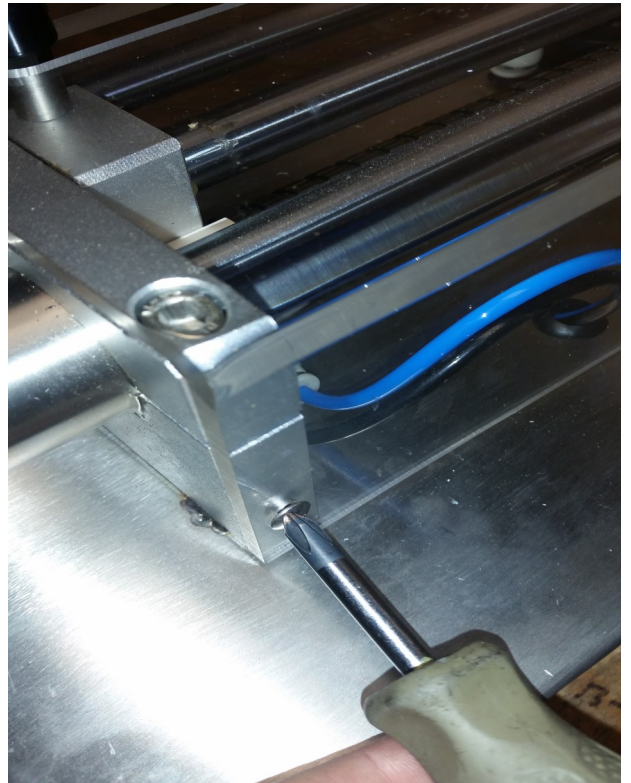
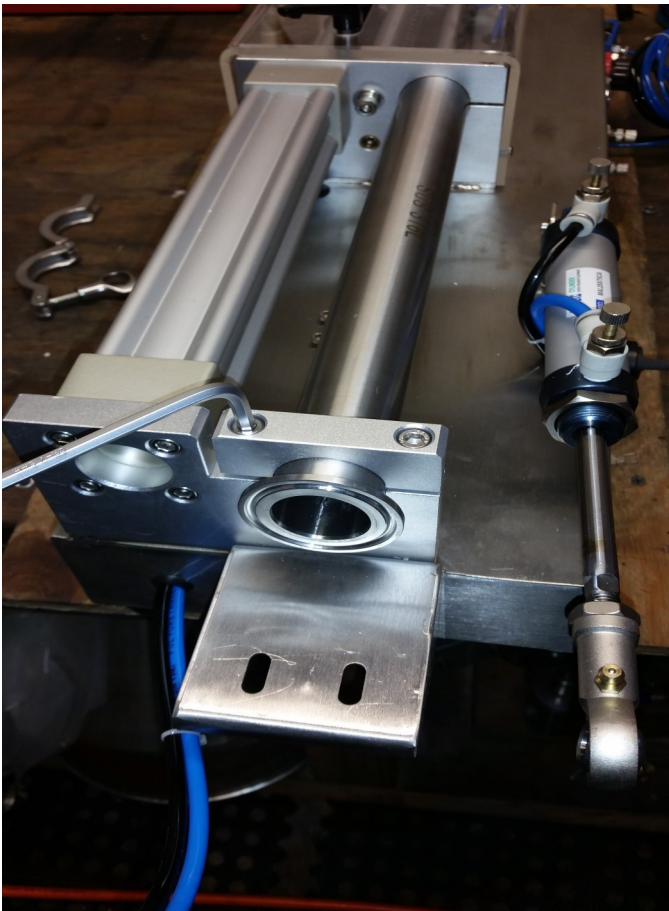
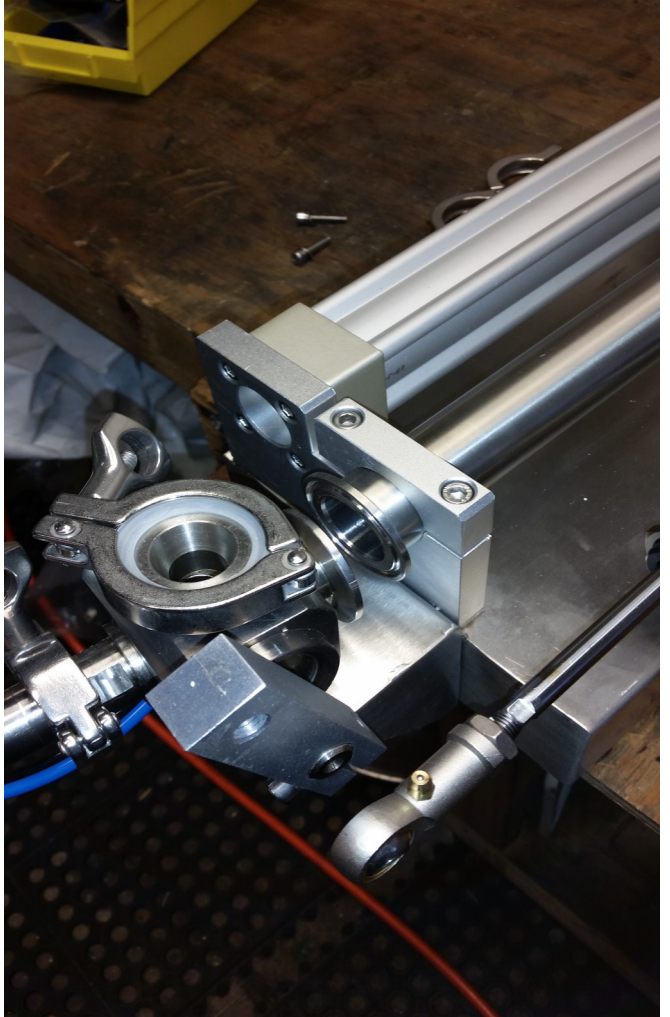
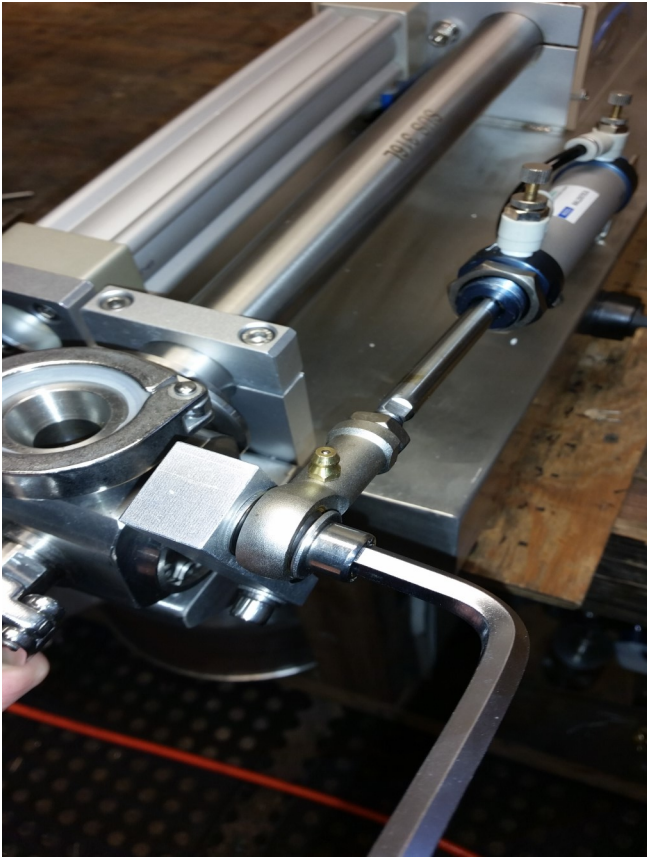

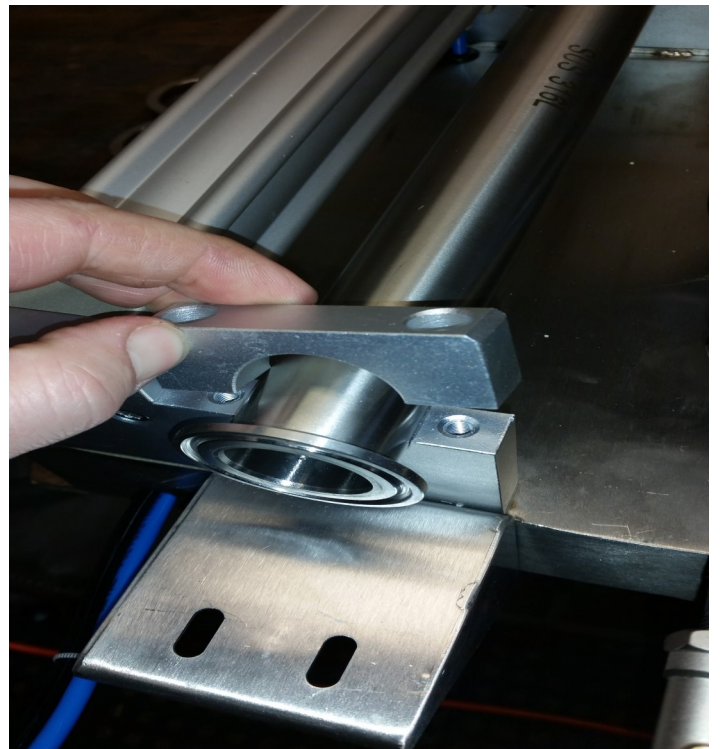
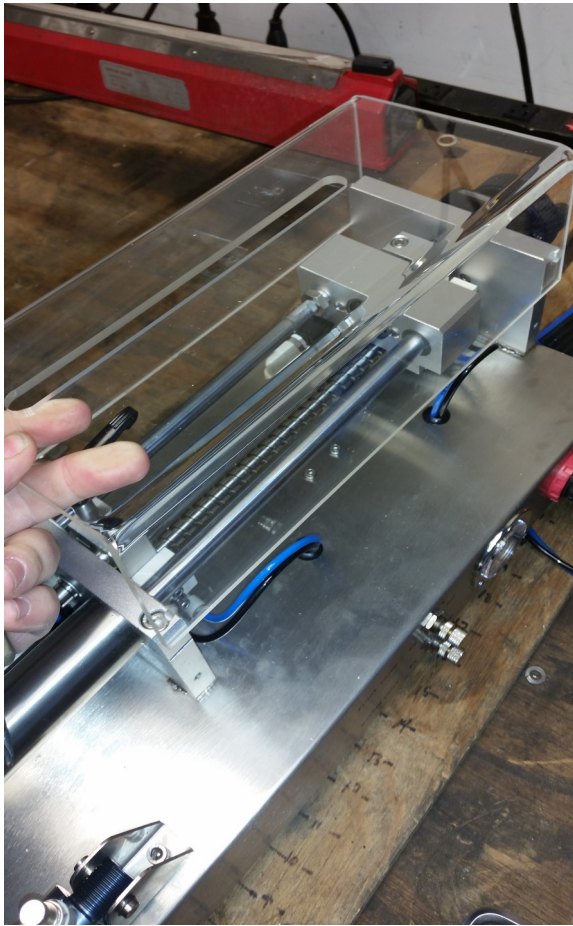

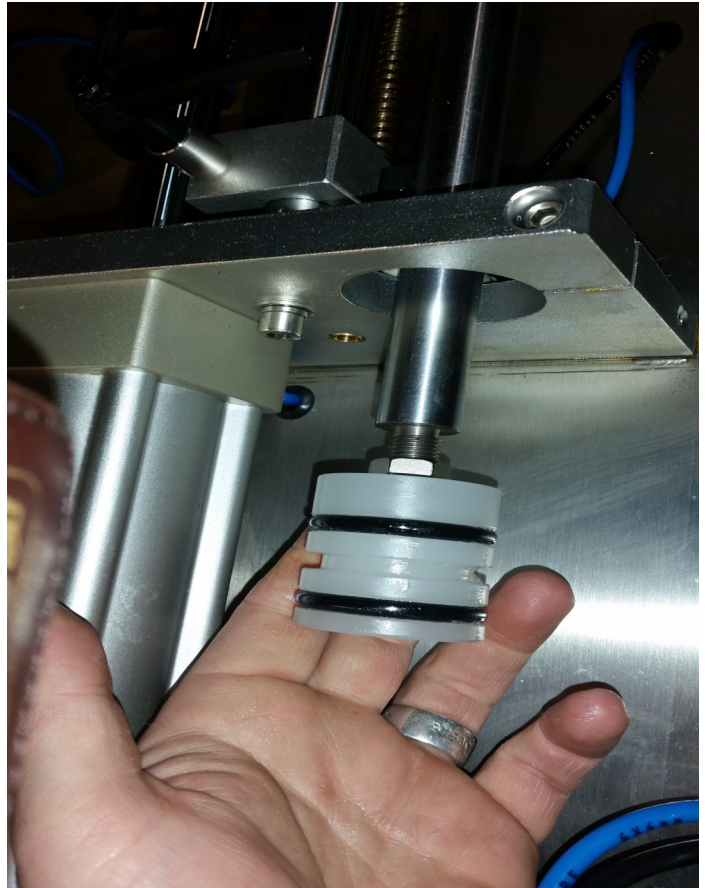
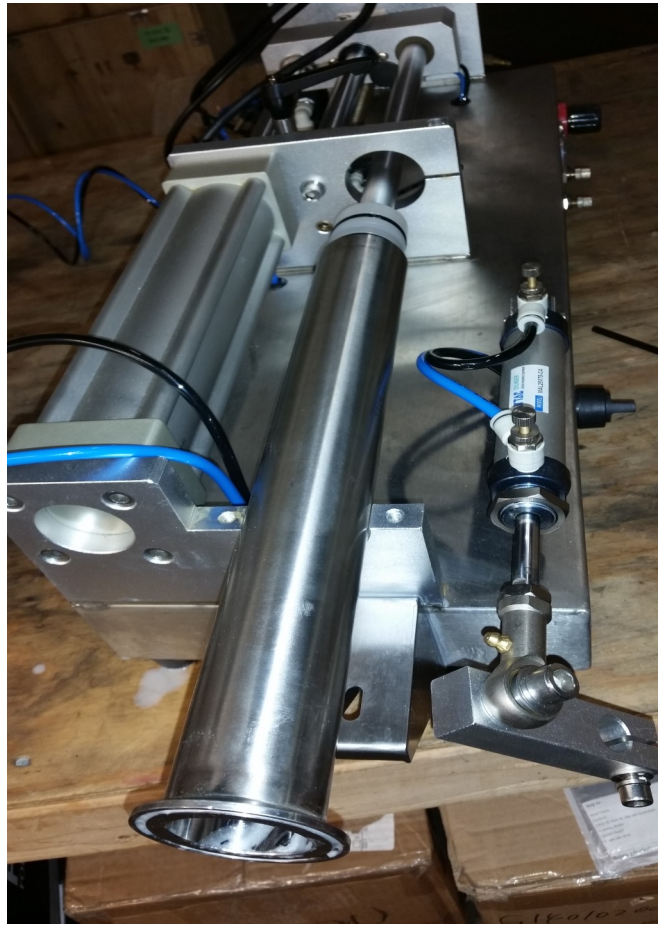

How to rebuild the rotary

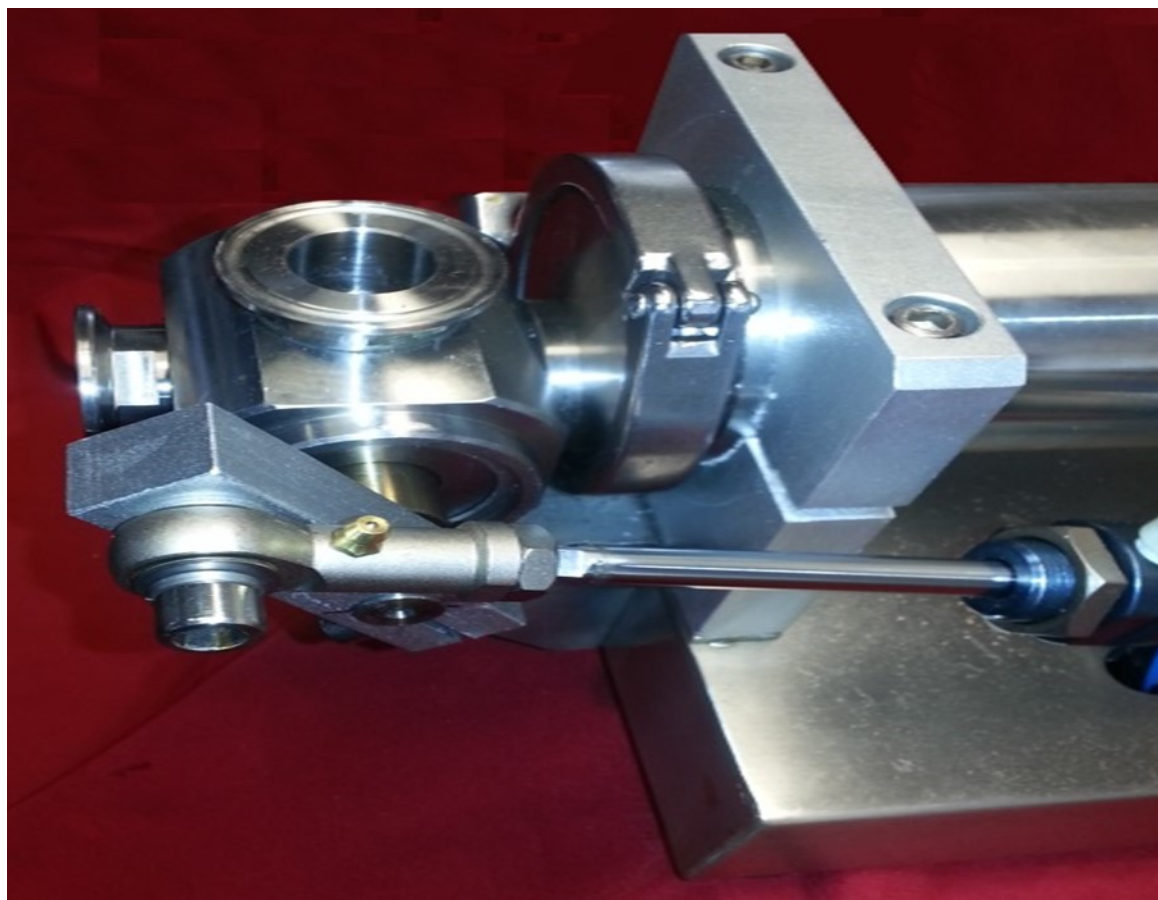

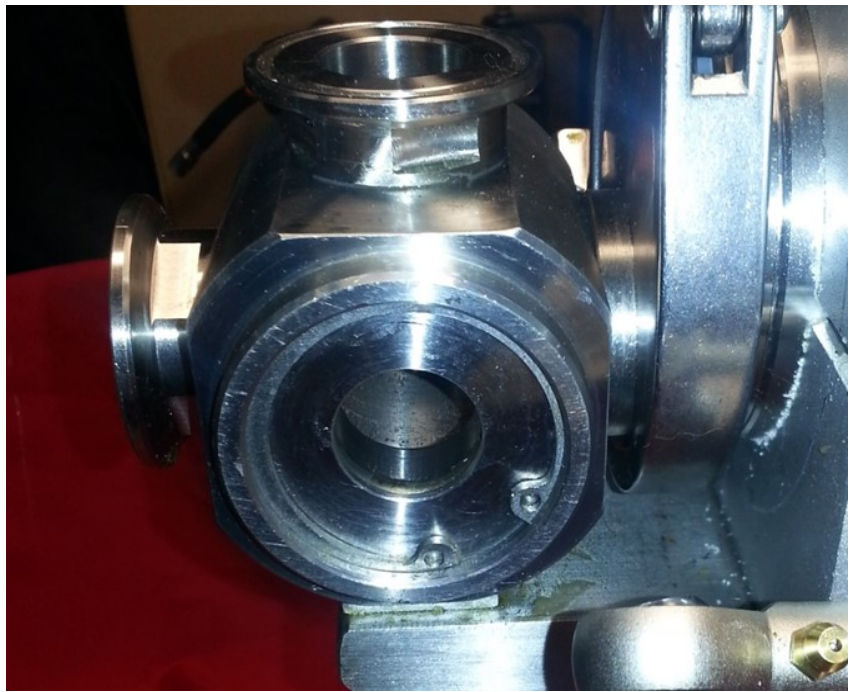
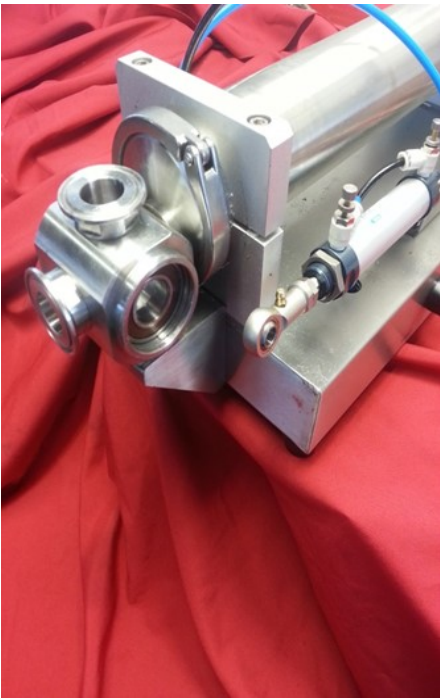



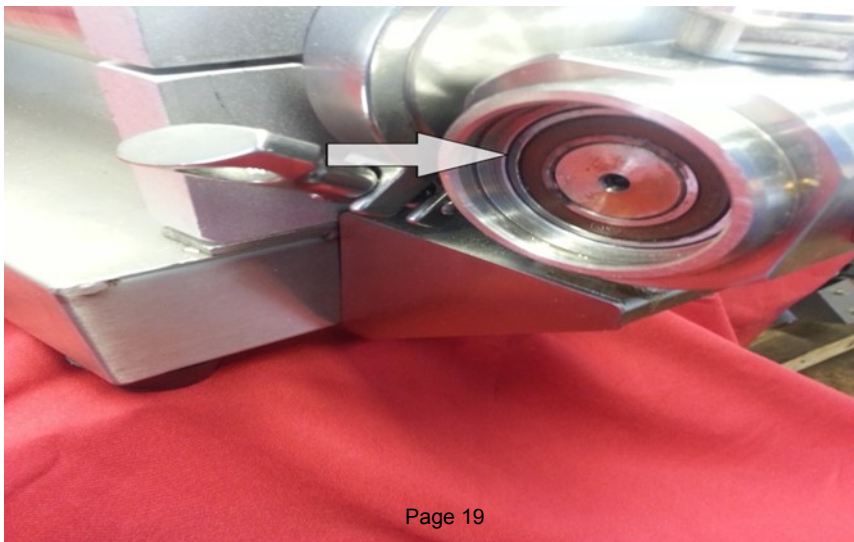
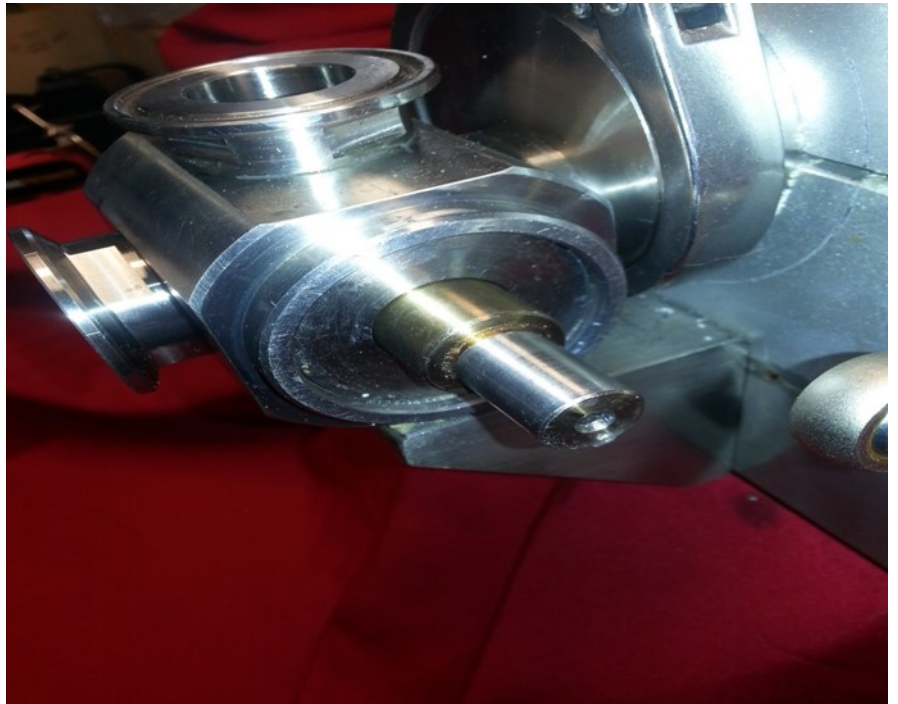



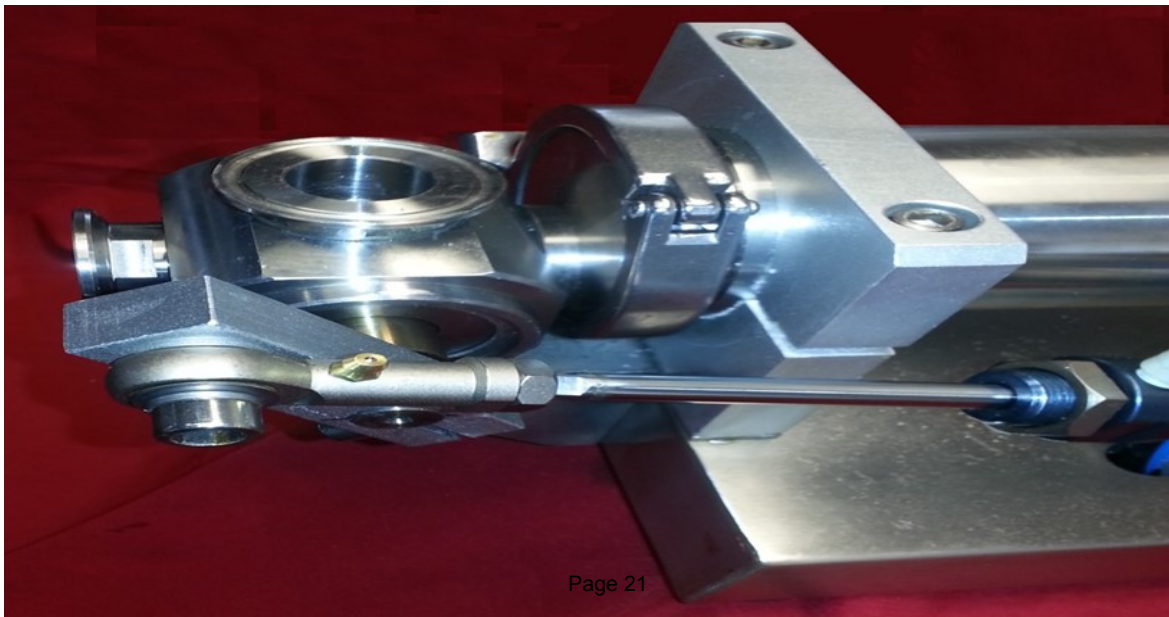
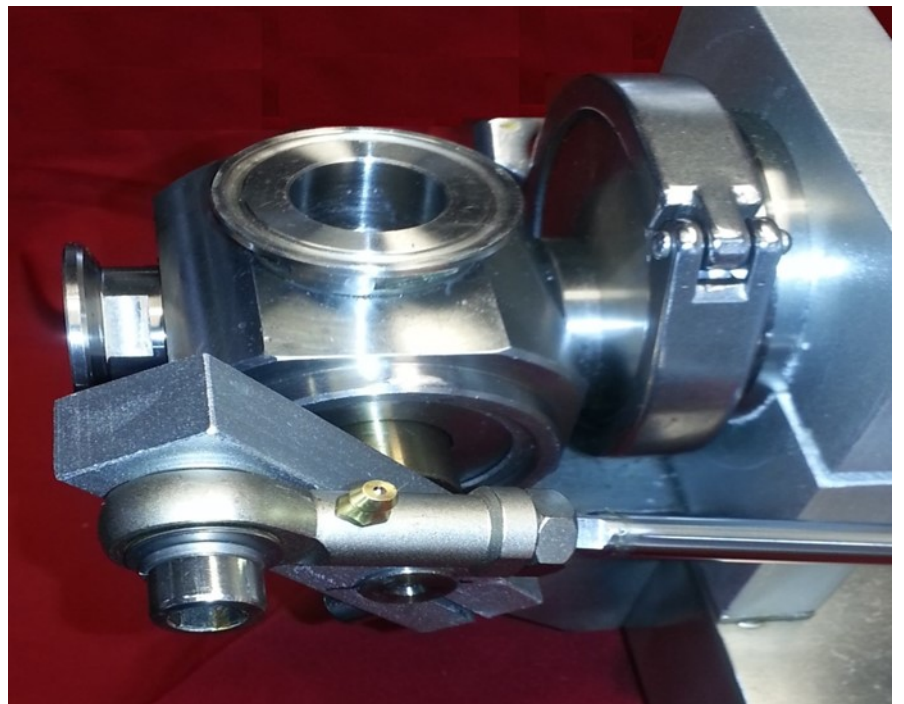
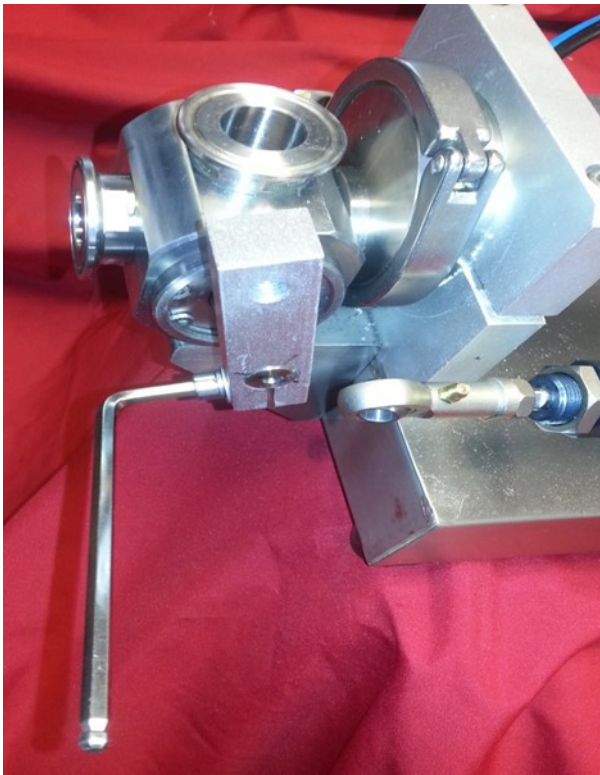
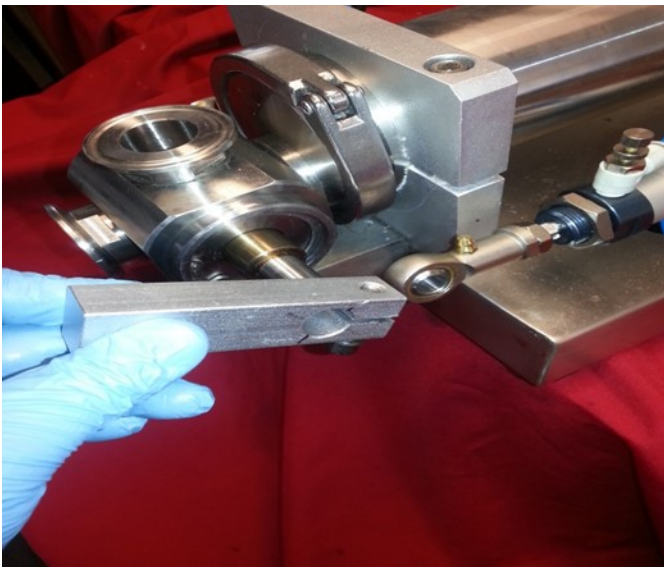

Seal Breakdown

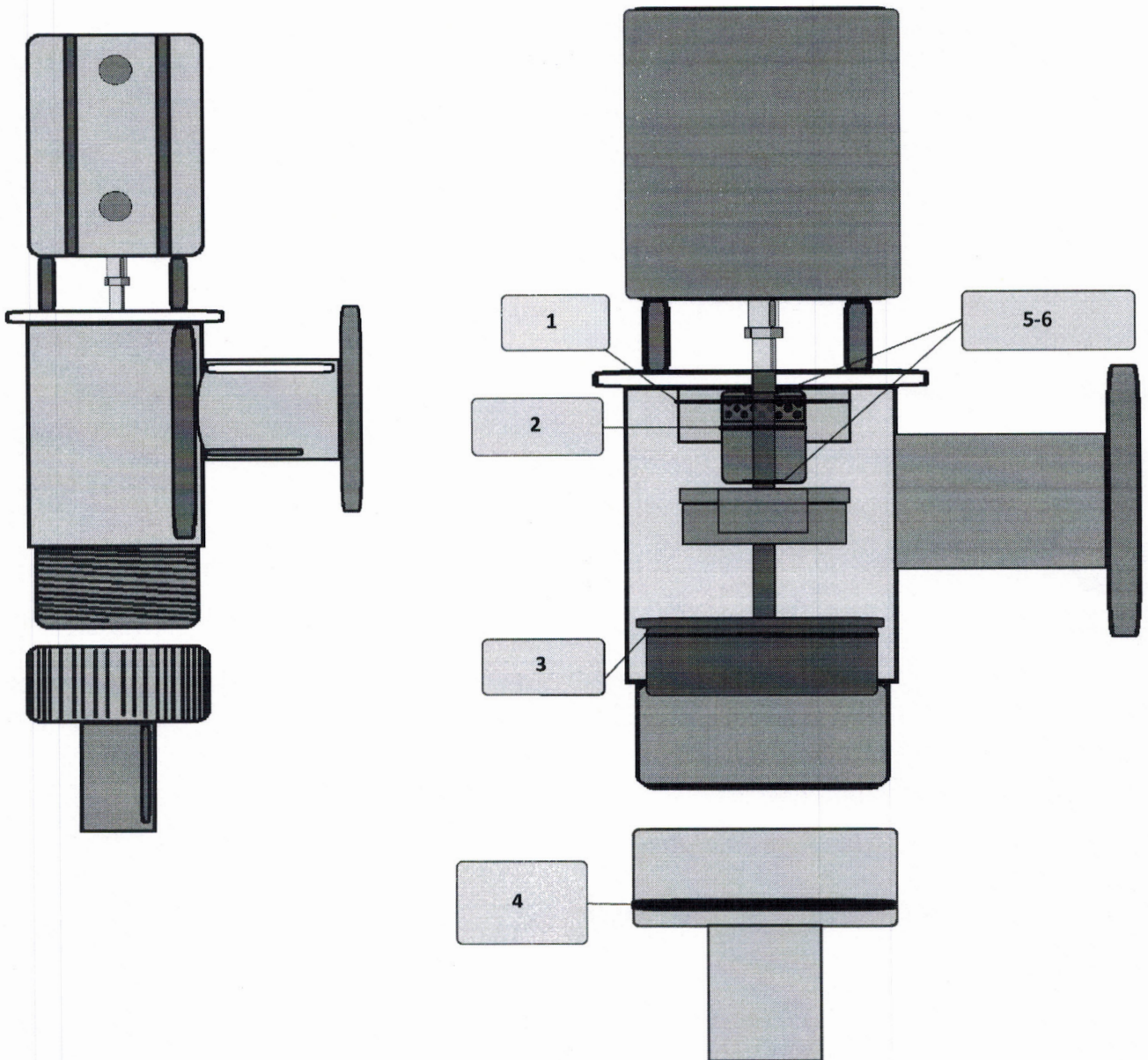

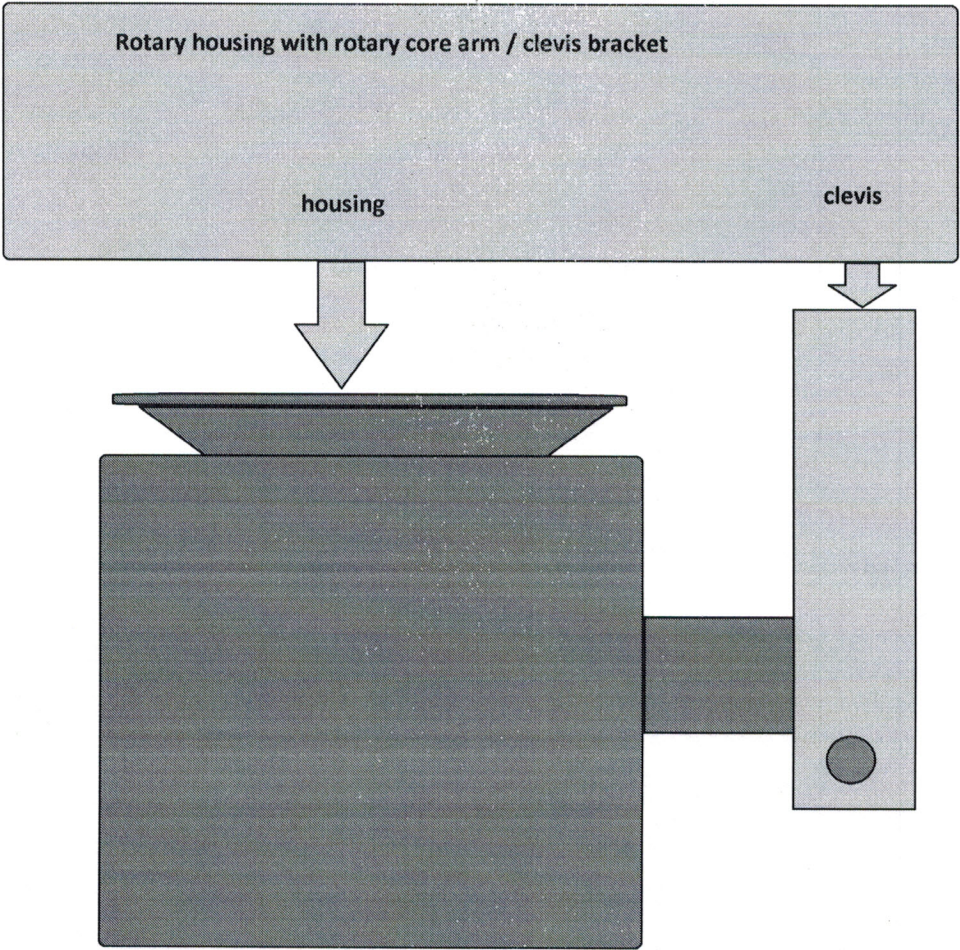

Rotary core in home position, the core arm/clevis will be facing up and in the forward most position

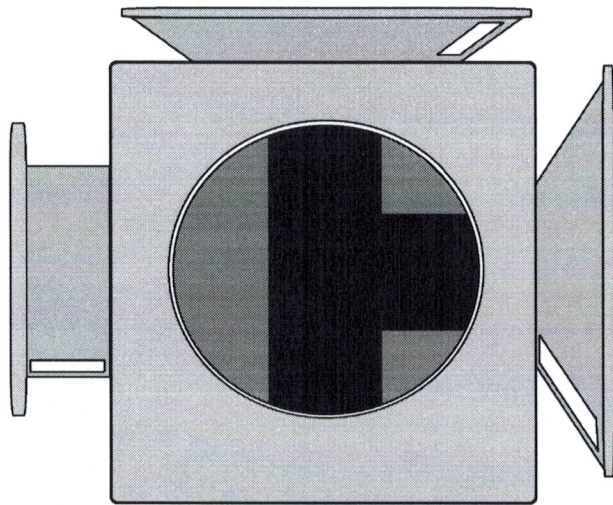

Rotary core in run position, the core arm/ clevis will be facing up and in the rearer most position

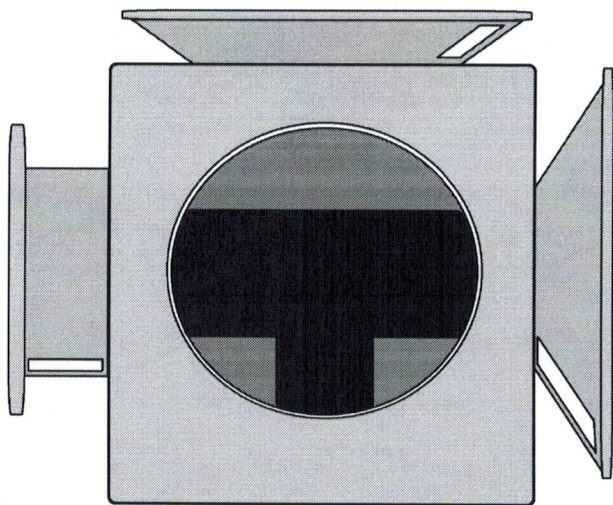

There are two orings(Shown below) pointing to the orings installed in the rotary core

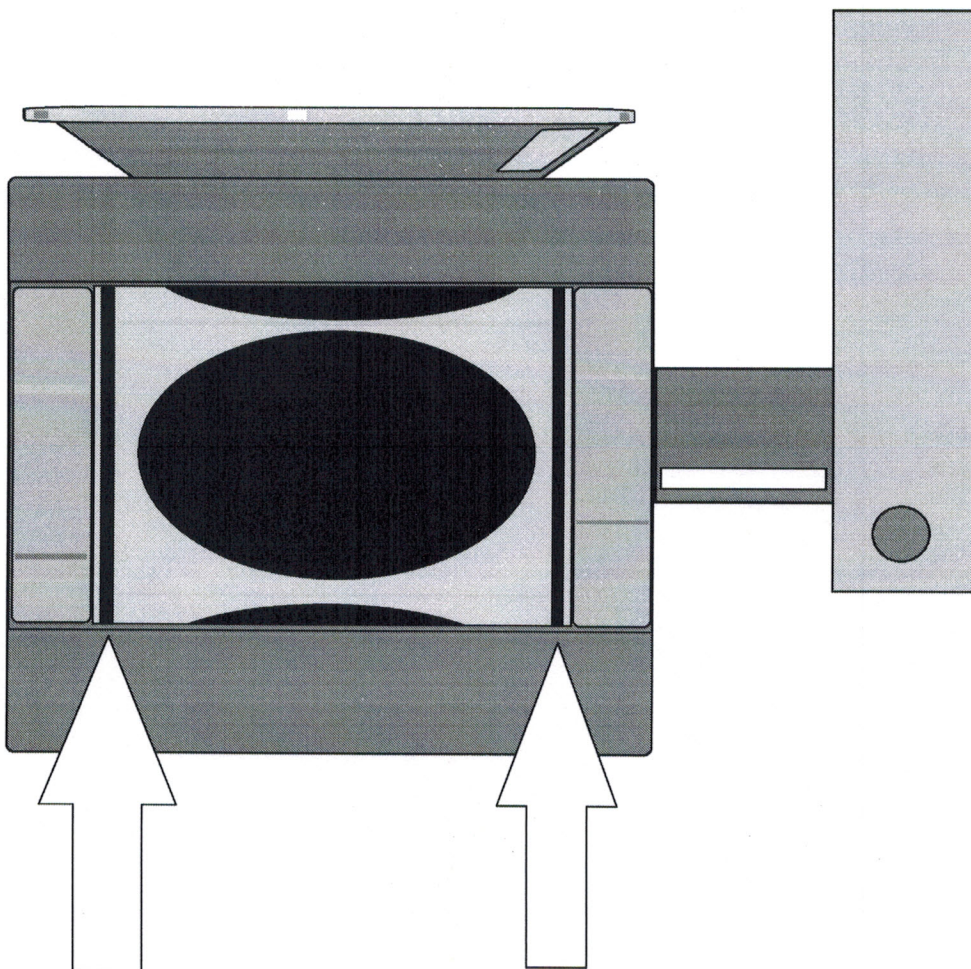

Two arrows below point to the orings on the main product piston that is housed inside of the steel product cylinder

