

SGY-120

Fully Pneumatic Piston Filling Machine

SGY Series (Liquid Only)

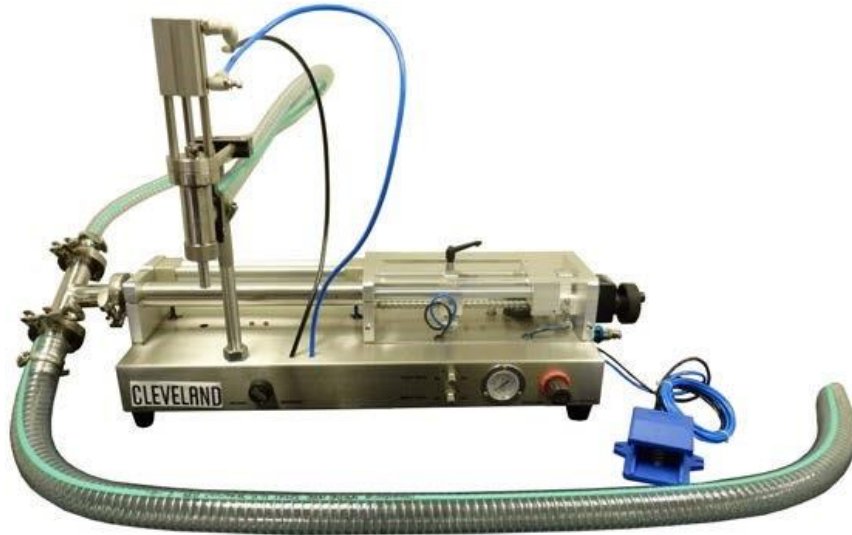

Operation Manual

(Please read it carefully before using the machine!)

ATTENTION:

Machine must be completely torn down, cleaned, sanitized, and lubricated with H3 food grade lubricant prior to use. A recommended lubricant has been provided.

Please note the hose provided is NOT sanitary hose unless specifically requested. The machine is 316SS Food Grade equipment.

**This machine requires an air compressor.
We would recommend a 20+ gallon compressor.
The air requirements for this machine are 5cfm@90psi.**



Table of Contents

| | |
|--|-----------|
| Chapter 1 Overview | 3 |
| 1-1 Overview | 3 |
| 1-2 Features | 3 |
| 1-3 Parameters..... | 3 |
| 1-4 Working Principle..... | 3 |
| 1-5 Working Process..... | 4 |
| 1-6 Available Range..... | 4 |
| Chapter 2 Operation Instruction..... | 6 |
| 2-1 Preparation | 6 |
| 2-2 Operation Method | 7 |
| 2-3 Fault Analysis and Troubleshooting..... | 8 |
| 2-4 Safety Instruction | 9 |
| Chapter 3 Machine Specification | 10 |
| 3-1– SGY-120 O Seal ring Listing Single Head | 10 |
| 3-2– SGY Series Machine Capacities | 11 |
| 3-2– SGY Series Machine Dimensions..... | 12 |



Chapter 1 Overview

1-1 Overview

The SGY series fully pneumatic filling machines are newly designed for liquid, paste, and cream filling, and its filling amount can be adjusted as required based on the specified range, featuring high stability, reliability and filling accuracy.

1-2 Features

1. All surface materials of this machine are crafted of 316 stainless steel, which features high acid-resistance and corrosion-resistance properties, as well as presenting a high quality finish.
2. You can operate it safely and easily and adjusting the filling amount can be performed within the range as required with high accuracy.
3. Its reasonable layout enables you to easily disassemble, safely operate, and easily clean the filler. I
4. Due to a total lack of electrical components, this filler can be used safely in a wide array of hazardous or moist environments.

1-3 Parameters

| Model No. | Filling Capacity (ml) | Pressure Range (MPa) | Filling Precision | Speed (min./bottle) | Packing Dimension (mm ³) | Net Weight (kg) | Gross Weight (kg) |
|-----------|-----------------------|----------------------|-------------------|---------------------|--------------------------------------|-----------------|-------------------|
| SGY-120 | 30-120 | 0.4-0.6 | +/-1% | 0-50 | 1035×29×270 | 15KG | 16.5KG |

1-4 Working Principle

The cylinder runs in reciprocating and linear manners to drive the piston and generate suction and thrust so as to draw and push your product.



1-5 Working Process

Open the inlet valve, adjust the working air pressure and select the working status (automatic or semiautomatic). During the operation, the rotary cylinder linkage is turned (opens a path towards the front while sealing towards the top), the fill head cylinder moves upwards to open the discharge valve, the piston cylinder actuates to move the piston forward, which dispenses material for filling (the speed can be adjusted by the “Behind” valve); after that, the fill head cylinder moves downwards to close the discharge valve to prevent dripping, the rotary cylinder linkage returns (seals towards the front while opening a path towards the top), the piston cylinder actuates to move the piston rearward, which pulls new product into the chamber for the next filling (speed can be adjusted by the “Front” valve). Thus the operation is accomplished.

1-6 Available Range

It is ideal for special industries such as food, daily chemistry, pesticide and medication.

1-7 Introduction to Parts and Specifications

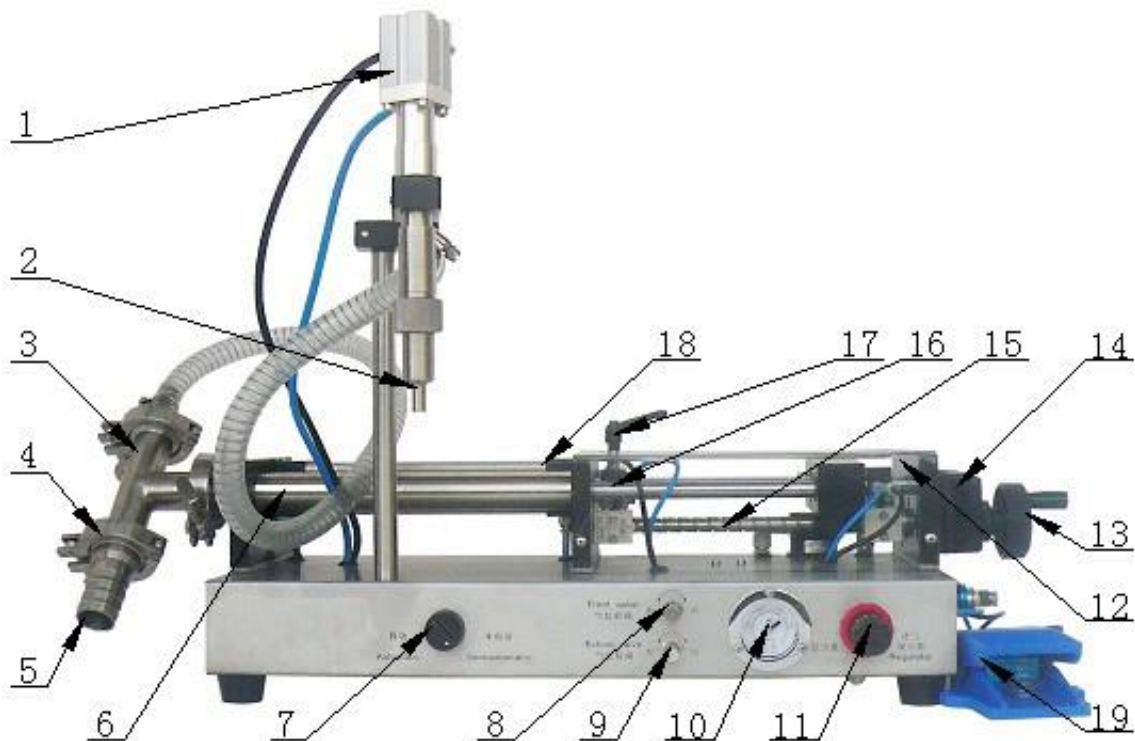

- | | |
|-----------------------------------|-------------------------------------|
| 1. Fill head air cylinder | 11. Air regulator |
| 2. Fill head reducer nozzle | 12. Protective covering |
| 3. Stainless T joint | 13. Rotating hand wheel |
| 4. Stainless clamp | 14. Indicator |
| 5. Draw hose | 15. Threaded adjustment shaft |
| 6. Product chamber | 16. Traversing block (sensor mount) |
| 7. Automatic/Semiautomatic switch | 17. Lock handle |
| 8. Forward speed valve | 18. Product chamber |
| 9. Return speed valve | 19. Foot pedal |
| 10. Air gauge | |



Chapter 2 Operation Instruction

2-1 Preparation

1. Precautions

- (1) The inlet air pressure should be 0.5-0.8Mpa and the working air pressure should be 0.4-0.5 Mpa.
- (2) Keep all appendages clear of moving parts during operation.

2. Filling amount troubleshooting

Adjust the filling amount as follows:

- (1) Put materials to be filled into the container.
- (2) Prepare measuring cup or scale to identify quantities desired.
- (3) Turn the hand wheel to adjust the variable sensor to desired range.
- (4) Check to ensure that the operation switch is set to Semiautomatic, use the foot pedal to control the cycle, measure the obtained product to see whether it is in the desired quantity. If not, proceed by the following:
 - A Loosen the locking handle on the adjustable sensor.
 - B Turn the hand wheel clockwise or counterclockwise.
 - C Repeat step 4, using a measuring cup or bottle to measure the materials and adjust the handwheel until the obtained result is within the desired range.
 - D Tighten the locking handle on the adjustment sensor to avoid parts shifting and influencing the filling accuracy.

2-2 Operation Method

- (1) Connect the air source and slide the air inlet collar toward the machine.
- (2) Check whether the air pressure meter is in the specified range (roughly reading in the “12-3 o’clock” range). If not, draw the air pressure knob outwards to unlock, rotate the pressure regulator until the pressure is in the specified range (0.40.5Mpa) and push the knob back in to lock.
- (3) Use the Auto/Semiauto switch to set the filler to the desired operation method.
- (4) To make an adjustment, you can loosen the locking handle on the adjustment sensor, rotate the handwheel, take note of the value on the position display and fasten the handle.
- (5) Adjust the front valve (for adjusting drawing speed) and behind valve (for adjusting filling speed) as shown in Figure 1 to get reasonable drawing and filling speed.



Figure 1 to get reasonable drawing and filling speed.

- (6) Fill the container with product and prepare the container to be filled.
- (7) Proceed with filling and control the operation with the foot pedal. Step on the foot pedal once to finish each filling operation. You can adjust and use the Automatic function if you are proficient enough to keep up with the filling speed.



2-3 Fault Analysis and Troubleshooting

| Symptom | Analysis | Troubleshooting |
|----------------------------|---|--|
| The machine fails | Check whether the air pressure collar is open | Open it |
| | Check whether the air source is open (compressor) | Open it |
| | Check whether the value on air pressure meter is within the correct range | Adjust it to 0.4-0.5MPa |
| | Check whether there is leakage on the pipe joint or damage on air lines | Insert the pipe again or change another one |
| | Check whether the air amount is adjusted to the minimum (tightened too much) via the front valve and behind valve | Adjust the valves to the working status |
| | Check whether the air amount on the fill head cylinder is adjusted to the minimum (tightened too far) | Adjust the throttle to the working status |
| | Check cleanliness of the machine. Product may be hardened, tacky, or sticky, causing rotary assemble or main piston to be stuck | Clean the machine |
| Filling is not even | Check for air leakage in all air line connections. | Fasten each joint |
| | Check for leakage in the product chamber | Replace o-rings |
| | Check product level inside hopper | Add product |
| | Check for correct speeds during filling and drawing actions | Adjust the front valve and behind valve to the stable status |
| | Check whether the material viscosity is even | Make materials be even |



2-4 Safety Instruction

1. You can use soap and warm water to clean the machine. Fill hopper with cleaning agent and water; cycle until discharge is clear of any product; fill hopper with clean water and cycle until water is clear.
2. Never use sharp tools on any parts surface when cleaning the internal parts and install the parts when they are dry.
3. Use lubricant for all moving parts.
4. Check the o-rings of all parts and replace damaged rings.
5. Check whether there is damage or leakage on the air lines.
6. Fasten screws of all parts.
7. Never clean the filler via harsh or abrasive cleaners to protect the machines integrity.
8. Never cycle the filler without a product.
9. Never put hard materials into the hopper.
10. Filler should be on a flat surface in a dry place with little dust and enough room for movement during each filling cycle.
11. Use the machine in air-current environment when volatile liquid is to be filled.
12. Body or materials should be far away from moving parts and our factory takes no responsibility for any machinery and human injury due to it.
13. Cut off the air source when repairing/replacing parts/cleaning.
14. Never use organic flux to clean the machine, such as gasoline, benzene, xylene, banana oil and sodium hypochlorite.

Chapter 3 Machine Specification

3-1– SGY-120 O Seal ring Listing Single Head

| No. | Type | Size/metric | size/american standard | Material | Qty |
|-----|--------------------|--------------|------------------------|-----------------|------|
| 1 | O Seal ring | Φ16mm*Φ4mm | DASH 208 | nitrile rubber | 2pcs |
| 2 | O Seal ring | φ12mm*Φ3mm | dash 206 | nitrile rubber | 1pcs |
| 3 | O Seal ring | φ28mm*φ2.5mm | dash 122 | nitrile rubber | 2pcs |
| 4 | Sillicon Seal ring | 1.5 inch | 1.5 tri clamp | Silicone rubber | 3pcs |
| 5 | O Seal ring | φ12mm*φ3mm | DASH 206 | nitrile rubber | 1pcs |
| 6 | O Seal ring | φ18mm*φ2mm | DASH 115 | nitrile rubber | 1pcs |
| 7 | O Seal ring | φ13mm*φ2.5mm | DASH 113 | nitrile rubber | 1pcs |
| 8 | O Seal ring | φ5.5mm*φ3mm | DASH 202 | nitrile rubber | 2pcs |
| 9 | O Seal ring | φ18mm*φ3mm | DASH 210 | nitrile rubber | 1pcs |
| | | | | | |



3-2– SGY Series Machine Capacities

| Model No. | Filling Capacity | Pressure Range (MPa) | Filling Precision | Speed (min./bottle) | Dimension LxWxH inches | Weight (lb) |
|-----------|----------------------------------|----------------------|-------------------|---------------------|------------------------|-------------|
| SGY-60 | 0.34 - 2.0 oz / 10ml - 60ml | 0.4-0.6 | 1%-2% | 0-50 | 31x10x19 | 35 |
| SGY-120 | 1.0 – 4.0 oz / 30ml - 120ml | 0.4-0.6 | 1%-2% | 0-50 | 34x14x19 | 37 |
| SGY-250 | 1.5 - 8.5 oz / 45ml - 250ml | 0.4-0.6 | 1%-2% | 0-50 | 36x15x19 | 56 |
| SGY-500 | 2.5 - 16.9 oz / 75ml - 500ml | 0.5-0.8 | 1%-2% | 0-50 | 44x15x19 | 58 |
| SGY-1000 | 3.5 - 33.5 oz / 100ml - 1000ml | 0.5-0.8 | 1%-2% | 0-50 | 47x17x19 | 85 |
| SGY-2500 | 8.5 - 84.5 oz / 250ml - 2500ml | 0.5-0.8 | 1%-2% | 0-30 | 52x13x19 | 91 |
| SGY-5000 | 16.0 - 169.0 oz / 500ml - 5000ml | 0.5-0.8 | 1%-2% | 0-15 | 51x15x19 | 128 |

3-2- SGY Series Machine Dimensions

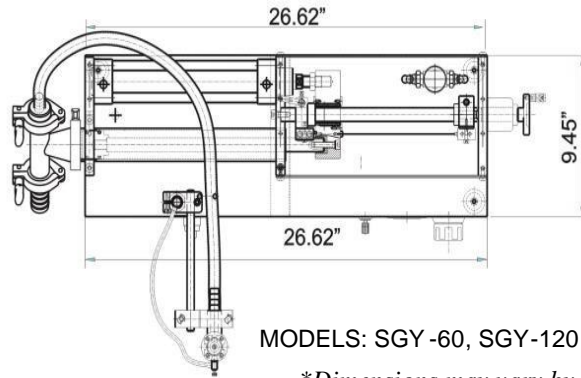
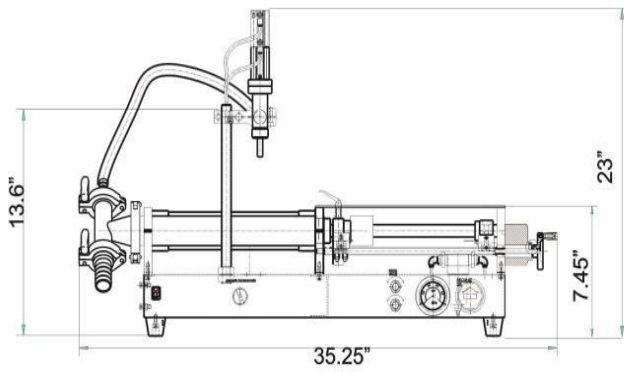

MODELS: SGY-60, SGY-120, SGY-250

**Dimensions may vary by model*

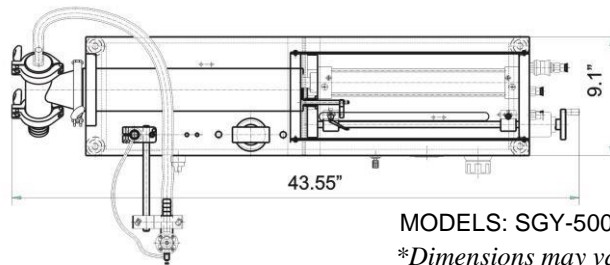
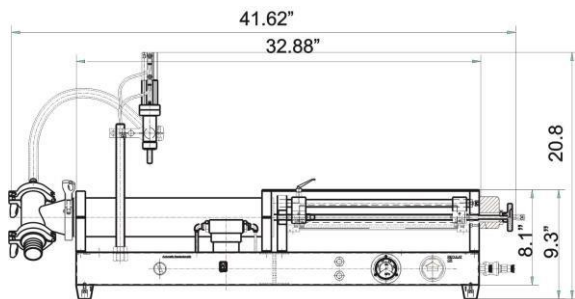

MODELS: SGY-500, SGY-1000

**Dimensions may vary by model*

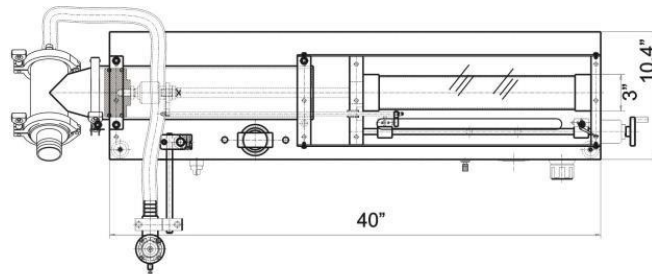
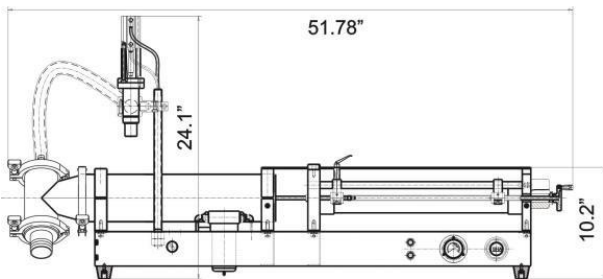

MODELS: SGY-2500, SGY-5000

**Dimensions may vary by model*