

SGY-5000-D

Fully Pneumatic Piston Filling Machine

SGY Series (Liquid Only)



Operation Manual

(Please read it carefully before using the machine!)

ATTENTION:

Machine must be completely torn down, cleaned, sanitized, and lubricated with H3 food grade lubricant prior to use. A recommended lubricant has been provided.

Please note the hose provided is NOT sanitary hose unless specifically requested. The machine is 316SS Food Grade equipment.

**This machine requires an air compressor.
We would recommend a 20+ gallon compressor.
The air requirements for this machine are 5cfm@90psi.**



Table of Contents

Chapter 1 Overview	3
1-1 Overview	3
1-2 Features	3
1-3 Parameters.....	3
1-4 Working Principle.....	3
1-5 Working Process	4
1-6 Available Range	4
Chapter 2 Operation Instruction.....	6
2-1 Preparation.....	6
2-2 Operation Method.....	7
2-3 Fault Analysis and Troubleshooting.....	8
2-4 Safety Instruction.....	9
Chapter 3 Machine Specification	10
3-1– SGY Series Single & Dual Head (same size just x 2) Hose Dimensions.....	10
3-2– SGY Series Machine Capacities	11
3-2– SGY-D Series Machine Dimensions.....	12



Chapter 1 Overview

1-1 Overview

The SGY series fully pneumatic filling machines are newly designed for liquid, paste, and cream filling, and its filling amount can be adjusted as required based on the specified range, featuring high stability, reliability and filling accuracy.

1-2 Features

1. All surface materials of this machine are crafted of 316 stainless steel, which features high acid-resistance and corrosion-resistance properties, as well as presenting a high quality finish.
2. You can operate it safely and easily and adjusting the filling amount can be performed within the range as required with high accuracy.
3. Its reasonable layout enables you to easily disassemble, safely operate, and easily clean the filler. I
4. Due to a total lack of electrical components, this filler can be used safely in a wide array of hazardous or moist environments.

1-3 Parameters

Item	Available range	Filling range		Filling accuracy		Working air pressure	Throughput	Outline (length x width x height)
		Cream	Liquid	Cream	Liquid			
SGY-5000K-2	Liquid	N/A	500~5000ml	N/A	±2%	5~8KG/CM	0~30 bottle/minute	1018×555×337mm

1-4 Working Principle

The cylinder runs in reciprocating and linear manners to drive the piston and generate suction and thrust so as to draw and push your product.



1-5 Working Process

Open the inlet valve, adjust the working air pressure and select the working status (automatic or semiautomatic). During the operation, the rotary cylinder linkage is turned (opens a path towards the front while sealing towards the top), the fill head cylinder moves upwards to open the discharge valve, the piston cylinder actuates to move the piston forward, which dispenses material for filling (the speed can be adjusted by the “Behind” valve); after that, the fill head cylinder moves downwards to close the discharge valve to prevent dripping, the rotary cylinder linkage returns (seals towards the front while opening a path towards the top), the piston cylinder actuates to move the piston rearward, which pulls new product into the chamber for the next filling (speed can be adjusted by the “Front” valve). Thus the operation is accomplished.

1-6 Available Range

It is ideal for special industries such as food, daily chemistry, pesticide and medication.

1-7 Introduction to Parts and Specifications

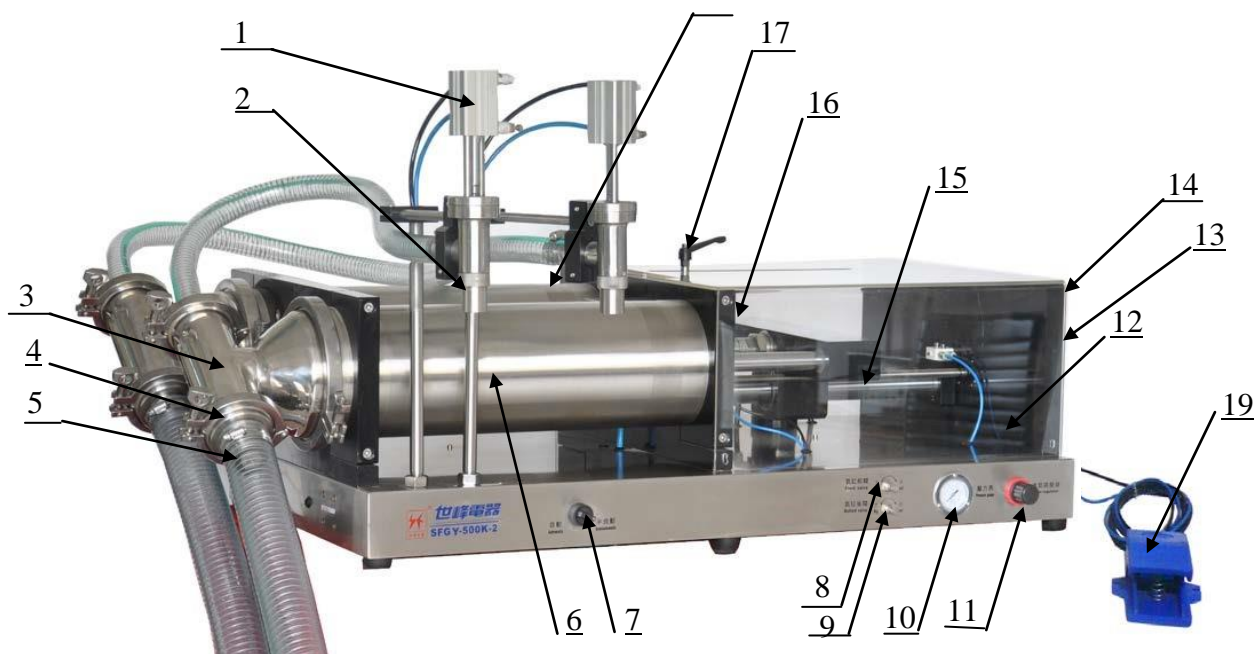

- | | |
|-----------------------------------|--------------------------------------|
| 1. Fill head air cylinder | 11. Air regulator |
| 2. Fill head reducer nozzle | 12. Protective covering |
| 3. Stainless T joint | 13. Rotating hand wheel |
| 4. Draw hose | 14. Indicator |
| 5. Draw hose check valve | 15. Threaded adjustment shaft |
| 6. Product chamber | 16. Crossmember |
| 7. Automatic/semiautomatic switch | 17. Adjustment locking handle/sensor |
| 8. Forward speed valve | 18. Product chamber |
| 9. Return speed valve | 19. Foot pedal |
| 10. Air gauge | |



Chapter 2 Operation Instruction

2-1 Preparation

1. Precautions

- (1) The inlet air pressure should be 0.5-0.8Mpa and the working air pressure should be 0.4-0.5 Mpa.
- (2) Keep all appendages clear of moving parts during operation.

2. Filling amount troubleshooting

Adjust the filling amount as follows:

- (1) Put materials to be filled into the container.
- (2) Prepare measuring cup or scale to identify quantities desired.
- (3) Turn the hand wheel to adjust the variable sensor to desired range.
- (4) Check to ensure that the operation switch is set to Semiautomatic, use the foot pedal to control the cycle, measure the obtained product to see whether it is in the desired quantity. If not, proceed by the following:
 - A Loosen the locking handle on the adjustable sensor.
 - B Turn the hand wheel clockwise or counterclockwise.
 - C Repeat step 4, using a measuring cup or bottle to measure the materials and adjust the handwheel until the obtained result is within the desired range.
 - D Tighten the locking handle on the adjustment sensor to avoid parts shifting and influencing the filling accuracy.

2-2 Operation Method

- (1) Connect the air source and slide the air inlet collar toward the machine.
- (2) Check whether the air pressure meter is in the specified range (roughly reading in the “12-3 o’clock” range). If not, draw the air pressure knob outwards to unlock, rotate the pressure regulator until the pressure is in the specified range (0.40.5Mpa) and push the knob back in to lock.
- (3) Use the Auto/Semiauto switch to set the filler to the desired operation method.
- (4) To make an adjustment, you can loosen the locking handle on the adjustment sensor, rotate the handwheel, take note of the value on the position display and fasten the handle.
- (5) Adjust the front valve (for adjusting drawing speed) and behind valve (for adjusting filling speed) as shown in Figure 1 to get reasonable drawing and filling speed.

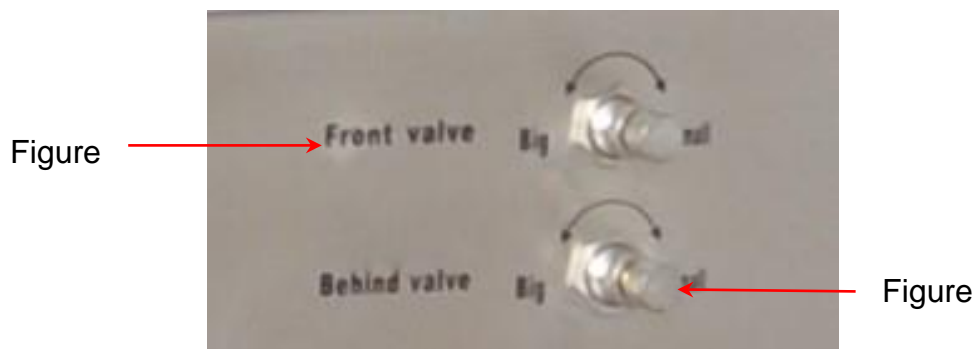

Figure 1 to get reasonable drawing and filling speed.

- (6) Fill the container with product and prepare the container to be filled.
- (7) Proceed with filling and control the operation with the foot pedal. Step on the foot pedal once to finish each filling operation. You can adjust and use the Automatic function if you are proficient enough to keep up with the filling speed.



2-3 Fault Analysis and Troubleshooting

Symptom	Analysis	Troubleshooting
The machine fails	Check whether the air pressure valve is open	Open it
	Check whether the gas source is open	Open it
	Check whether the value on air pressure meter is qualified	Adjust it to 5-8KG/CM
	Check whether there is leakage on the pipe joint or damage on pipes	Insert the pipe again or change another one
	Check whether gas amount is adjusted to the minimum or deadlock status via the front valve and behind valve	Adjust the valves to the working status
	Check whether the unidirectional throttle on the thin cylinder is adjusted to the minimum or deadlock to make the piston be blocked	Adjust the throttle to the working status
	Check whether the machine is clean. Materials may go bad to make the machine blocked if the machine is not timely cleaned.	Clean the machine
Filling is not even	Check whether there is leakage on the joint	Fasten each joint
	Check whether there is leakage in the piston cylinder	Replace the piston lock ring
	Check whether the materials to be filled are enough	Add materials
	Check whether the drawing and pushing speed is normal	Adjust the front valve and behind valve to the stable status
	Check whether the material viscosity is even	Make materials be even



2-4 Safety Instruction

1. You can use soap and warm water to clean the machine. Fill hopper with cleaning agent and water; cycle until discharge is clear of any product; fill hopper with clean water and cycle until water is clear.
2. Never use sharp tools on any parts surface when cleaning the internal parts and install the parts when they are dry.
3. Use lubricant for all moving parts.
4. Check the o-rings of all parts and replace damaged rings.
5. Check whether there is damage or leakage on the air lines.
6. Fasten screws of all parts.
7. Never clean the filler via harsh or abrasive cleaners to protect the machines integrity.
8. Never cycle the filler without a product.
9. Never put hard materials into the hopper.
10. Filler should be on a flat surface in a dry place with little dust and enough room for movement during each filling cycle.
11. Use the machine in air-current environment when volatile liquid is to be filled.
12. Body or materials should be far away from moving parts and our factory takes no responsibility for any machinery and human injury due to it.
13. Cut off the air source when repairing/replacing parts/cleaning.
14. Never use organic flux to clean the machine, such as gasoline, benzene, xylene, banana oil and sodium hypochlorite.

2-5 Annex table

No.	Term	Type (Model)	Quantity	Unit	Remark
1	Book Description	SGY-5000K-2	1	piece	——
2	“O” shape ring	φ135.89×φ7	4	piece	——
3	“O” shape ring	φ5×φ2.5	2	piece	——
4	“O” shape ring	φ10×φ2	2	piece	——
5	“O” shape ring	φ18×φ3	1	piece	——
6	“O” shape ring	φ25×φ3	1	piece	——



Chapter 3 Machine Specification

3.1 Machine Specifics – Oring List

Machine comes standard with buna orings

- 113 – Fill head**
- 148 – fill head / supply tank (hopper)**
- 275 – fill head**
- 224 - supply tank (hopper)**
- 120 - fill head nozzle**
- 108 - middle oring**
- 107 - middle oring**
- 121 - top**
- 116 - piston**
- 375 – Piston**
- 7” sanitary gasket**
- 3.5 inch T gaskets**

3-2– SGY Series Single & Dual Head (same size just x 2) Hose Dimensions

Measurements are in inches.

Model	Dispensing Hose		Draw Hose	
	Inside Diameter	Outside Diameter	Inside Diameter	Outside Diameter
SGY-60	1/2	3/4	1	1 1/4
SGY-120	1/2	3/4	1	1 1/4
SGY-250	1/2	3/4	1 1/2	1 3/4
SGY-1000	1/2	3/4	1 1/2	1 3/4
SGY-5000	1	1 1/4	2	2 1/2



3-3– SGY Series Machine Capacities

Model No.	Filling Capacity	Pressure Range (MPa)	Filling Precision	Speed (min./bottle)	Dimension LxWxH inches	Weight (lb)
SGY-60	0.34 - 2.0 oz / 10ml - 60ml	0.4-0.6	1%-2%	0-50	31x10x19	35
SGY-120	1.0 – 4.0 oz / 30ml - 120ml	0.4-0.6	1%-2%	0-50	34x14x19	37
SGY-250	1.5 - 8.5 oz / 45ml - 250ml	0.4-0.6	1%-2%	0-50	36x15x19	56
SGY-500	2.5 - 16.9 oz / 75ml - 500ml	0.5-0.8	1%-2%	0-50	44x15x19	58
SGY-1000	3.5 - 33.5 oz / 100ml - 1000ml	0.5-0.8	1%-2%	0-50	47x17x19	85
SGY-2500	8.5 - 84.5 oz / 250ml - 2500ml	0.5-0.8	1%-2%	0-30	52x13x19	91
SGY-5000	16.0 - 169.0 oz / 500ml - 5000ml	0.5-0.8	1%-2%	0-15	51x15x19	128

3-4- SGY-D Series Machine Dimensions

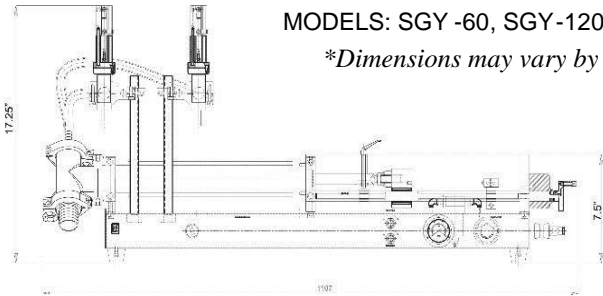

MODELS: SGY -60, SGY-120, SGY-250
**Dimensions may vary by model*

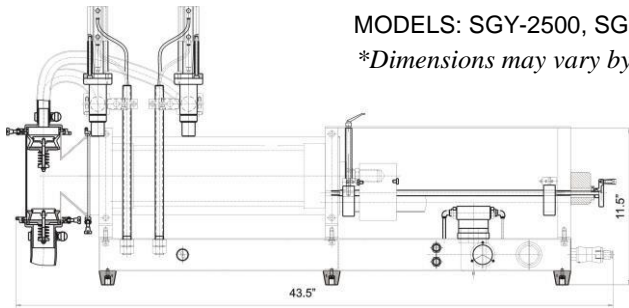
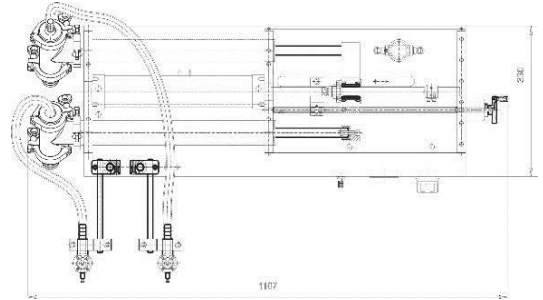

MODELS: SGY-2500, SGY-5000
**Dimensions may vary by model*

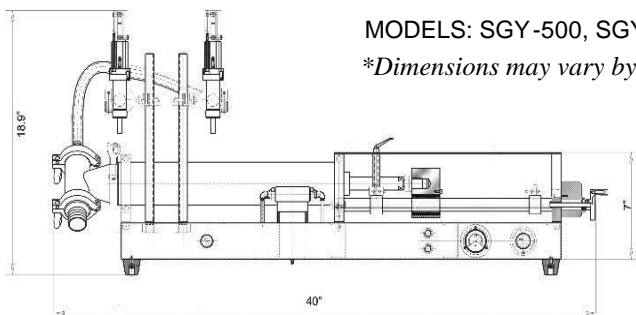
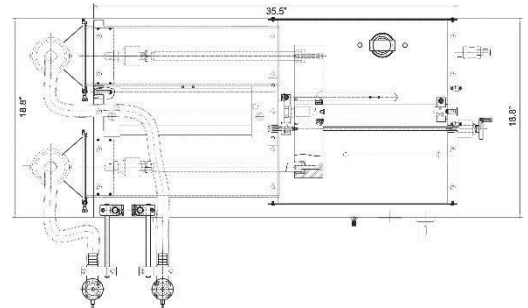

MODELS: SGY-500, SGY-1000
**Dimensions may vary by model*

