

CE-5800-HVE

Continuous Sealer

Operation Manual



866-888-6327

sales@clevelandequipment.com

4403 Delp Street • Memphis, TN 38118

www.clevelandequipment.com

Contents

Preface	4
1. Product Introduction	5
1.1 Application	5
1.2 Products' Feature	5
1.3 Operation Principles	5
1.4 Technical Specification	6
2. Safety	8
2.1 Preparation	8
2.2 Precautions on safety	8
2.3 Using environment	9
3. Conveying & storage	10
3.1 Carton packaging configuration	10
4. Installation	11
4.1 Essential condition for installation	11
4.2 Installation environment	12
4.3 Installation steps	13
5. Startup and commissioning	14
5.1 Controlling panel	14
5.2 Power on	15
5.2.1 Power connection	15
5.2.2 Startup procedure	16
5.2.3 Stop operation	16
5.2.4 Emergency stop switch	16
5.3 Commissioning	17
5.3.1 Replacement and adjustment of the sealing belt	17
5.3.2 Forward-and-backward adjustment of conveyor table	18
5.3.3 Adjustment of sealing belt deviation	19
5.3.4 Adjustment of conveyor table height	19
5.3.5 Adjustment of conveyor belt deviation	20

5.3.6 Pressure adjustment of embossing wheel	20
6. Standard Operation & Parameter Setting	21
6.1 Preparation, adjustment and inspection before operation.....	22
6.2 Parameter Setting.....	23
6.3 Menu	24
6.4 File Edit.....	26
6.5 Preview.....	28
6.6 Advanced.....	29
7. Maintenance	31
7.2 Maintenance period table.....	32
8. Troubleshooting	33
8.1 Troubleshooting	33
8.2 Motor maintenance.....	37
9. Storage	38
9.1 Storage of short time	38
9.2 Storage of long time.....	38
9.3 Start the machine after long-term storage.....	38
10. Electric schematic diagram	39
11. Parts Diagrams	40
11.1 Sealing part 1:.....	40
11.2 Sealing part 2 :.....	42
11.3 Sealing part 3.....	45
11.4 Worm gear box assembly	47
11.5 Worm gear box motor assembly	49
11.6 Conveyor Table Parts	51
11.7 Chassis components	53

Preface

Thank you for buying the intelligent inkjet band sealer of CE-5800-HVE BAND SEALER.

The Manual is suitable for the model CE-5800-HVE BAND SEALER series.

This instruction manual has following content:

- Instruction on the product
- Precaution on safety
- Transportation and storage
- Installation
- Operation and commissioning
- Maintenance
- Troubleshooting

This manual gives a description of the installation and use of the product, and it includes following contents: the product's transportation, storage, installation, operation conditions, maintenance, troubleshooting and repairing.

Notice:

- Please read this manual carefully and understand it thoroughly before using..
- Make sure this manual is possessed by the operator or the managerial personnel of this product.
- Please retain this manual after reading and make sure it is available for reference if needed.
- Any questions, please contact the manufacturer or distributor.

Responsibilities:

- This manual is written carefully and for possible mistakes or the mistakes due to misunderstanding, the manufacturer does not take any responsibility.
- The manufacturer will not be responsible for the damage or problems caused by having not adopted the specified spare part.
- The manufacturer keeps the right of amendment on the parameter or parts without prior notice.
- All rights are reserved by manufacturer. And without written approval, printing of any part of this manual is forbidden. If found, the company reserves the right to pursue legal responsibilities.

Terms:

- Sealing belt (Teflon belt): to make the bag be out of touch of heating block to avoid influence the sealing effect.
- Heater: consist of copper block and heating tube.

1. Product Introduction

1.1 Application

This sealer can seal small packages, with a printing control operating system adopting the Linux operating system widely used worldwide, free and open source. The system has strong stability and scalability, and can run stably for a long time. Customers can freely adjust, the font size length, and rich content of the printing according to their own needs, and the machine has its own sealing counting function, which can be widely used in food, medicine, chemical, daily use, agriculture, and other industries. It is the best sealing equipment for bulk product packaging in factories and shops.

1.2 Products' Feature

- The touch screen operating system is a free and open source for the Linux, using a quad-core high-performance processor, with a main frequency of up to 1.5GHz, extremely fast response and smooth operation.
- Flat interface design: simple software interface appearance with guided scrolling prompt and friendly interaction.
- 5-inch IPS high-definition capacitive touch screen: a display resolution of 800x480, delicate and colorful display, 180 degrees visible angle.
- The market's exclusive double spelling smart input method: support various input modes like predictive typing in Chinese and English, handwriting input, Wubi entry, Cangjie input, making editing more efficient. The corresponding language input method can be automatically switched according to the system language.
- Support direct import of pictures in various formats: bmp, jpg, png, and any graphic element can be resized by dragging and scaling, eliminating the tedious operation of computer conversion.
- Unique font management function: users can import personal favorite fonts.
- Various printing contents: contents like the text, date, symbol, LOGO image, two-dimensional code, bar code, etc. can be printed.
- One-click switch languages: more than 20 languages supporting (including corresponding language input methods), and support for any language customization.
- Software support USB flash disk update, continuous maintenance optimization.

1.3 Operation Principles

After power supply is connected, electrothermal elements start to produce heat, which leads to rapid temperature rise of both upper and bottom heating blocks. Adjust temperature controller and speed-adjusting knob to get the required temperature and speed respectively. The sealing area of plastic packing bag is conveyed to the position between two sealing belts by conveyor belt first, then clamped by two sealing belts and delivered to the heating area. The plastic film is heated and softened. Under the pressure from pinch roller, the film binds. After this, the sealing part will be conveyed to the cooling area for cooling and forming, and then pressed by embossing roller for making stripe or grid pattern. Finally, through the inkjet printer, the production date, QR code, barcode, etc. are printed.

The running of transmission part of the sealer is started by motor, which drives sealing belts, guiding belts and conveyor belt through gears to run synchronously.

1.4 Technical Specification

Parameter Item	CE-5800-HVE (Vertical Type)
Voltage(V/Hz)	AC 220/50 110/60
Motor power(W)	50/100
Sealing power(W)	300×2
Sealing speed(m/min)	0~16 (0~24)
Sealing width(mm)	10
Temperature control range(°C)	0~300 (°C) (Stepless adjustable)
Distance from sealing center to conveyor table (mm)	200-320
Max. distance from sealing center to Bag Opening (Kg)	21
Max. overall loading of conveyor (Kg)	≤10
External dimensions (L×W×H) (mm)	954×400×548
Net weight (Kg)	40
Inkjet Printer Parameters	
Operating System	Linux
Size of Touch Screen	5 inch
Touch Screen Resolution	800×480
Processor	Quad-core high-performance processor, main frequency up to 1.5GHz (extremely fast response, smooth operation)
Memory	1G + 4G
Print head	TIJ2.5 Thermal foaming nozzle
Printing Font Height	1.5-12.7mm
Printing Length	Unlimited
Maximum Printing Lines	6 lines
Ink Type and Capacity	Oily/42ml
Languages in Touch Screen	Simplified Chinese, Traditional Chinese, English, Arabic, Turkish, Spanish, Portuguese, Korean, Russian (support customization)
Printing Content	Chinese, English, numbers, symbols, graphics (support any picture without format conversion), QR codes, barcodes (custom barcode content, real-time variable barcode), variable date (system custom), variable count (system Custom), variable QR codes (real-time variable data printing system, all online systems are customized models)
Counting	0-100000
Printing Volume of Ink Cartridge	About 200,000 times (take the production date of 4mm in height and 30mm in length as an example)



Printing Content Storage	200 pieces can be stored (each piece of printing content has a separate counting and storage function)
Printing Font	Adjustable (customizable printing font)
External Interface	USB
Online Operation	Optional (one host can control 1+N units)

2. Safety

2.1 Preparation

- This manual describes the transportation, storage, installation, starting, operation condition, maintenance, troubleshooting and repairing of this product.
- The installation of this machine should be operated by professional workers.
- Please obey this maintenance instruction
- Before using this machine, please read this instruction manual and understand it fully.
- Any questions, please contact the manufacturer or distributor.

2.2 Precautions on safety

- Pls confirm the machine voltage, frequency to prevent the accident.
 - This machine is in power system of single-phase three-wire, and the yellow and green wire is protective earth wire which should be grounding and could not be removed.
 - The power cord should be protected from pressing, pulling, and should be winded when it is not used.
 - Do not touch the electrical devices inside the machine after the power is turned on.
 - Do not touch any driving parts to avoid injury when the machine is in operation.
 - Do not open the machine hull, protection cover etc. when machine is on to avoid pinching, scalding or electric shock.
 - Do not touch the heating blocks to prevent from burns.
 - When the machine is repaired, please proceed when the heating blocks are fully cool to avoid burns.
 - Do not use the machine in corrosive and humid environments.
 - Do not optionally replace parts on the machine.
 - Keep the inside and outside of the machine clean and remove the surface adhesive materials from the Teflon belt in time.
 - Fill and exchange oil in worm-gear case regularly, and oil gear and sprocket (YP7408 semi-liquid gear oil).
- When the machine is not in use, the power supply should be switched off.

Keep this manual properly for easy reference in the future.

For example:

	<p>Danger!</p> <p>There may be severe accidents or death if this precaution is ignored!</p>
---	--

	<p>Warning!</p> <p>There may be severe accidents or deaths if this precaution is ignored!</p>
---	--

	<p>Warning!</p> <p>There may be personal injury or property loss if this precaution is ignored!</p>
---	--

2.3 Using environment

This product is designed to operate under room temperature and if environmental conditions are bad, (for example, corrosivity in atmosphere and the environmental temperature over 30°C or lower than 5 °C), please contact the manufacturer or the supplier.

3. Conveying & storage

3.1 Carton packaging configuration

- Packed tightly by wad in the carton

Note: The maximum layers should not be more than 5 while palletizing.

- Please ensure that the wrapping film is wrapped stably on the machines.
- Please transfer the carton according to the arrow on it, do not transfer reversely
- Please use the forklift to transfer the machines palletized on the pallets

Note: Each machine is equipped with conveyor, hold the handle when moving the machine, do not hold the conveyor to move the machine

4. Installation

Before the operation of installation, please read this manual. By reading this manual, the things about how to install, start, and usage and maintenance of this machine can be learnt. If there are problems caused because of not referring to this manual, the manufacturer will not take any responsibility.

The manufacturer hopes the client will use the machine without breakdowns for a long time. If there is any problem, please contact with the supplier or the manufacturer.

4.1 Essential condition for installation



Caution! Harm to machine!

Without essential condition for installation, machine will be damaged.

Be careful injured!

Please obey the essential condition for installation.

Please assure the installation environment satisfy basic safety regulations.

4.2 Installation environment

- No inflammable and explosive gas is allowed.
- Environment temperature: 5-30°C. If need operation under other temperature, please confirm with supplier or dealer first.
- Environment pressure, standard atmospheric pressure
- Assure power environment satisfy requirements (refer to nameplate).
- No inclined is an important factor of the machine successful operating.
- Leave enough space to assure good ventilation for heat dissipation. At least 10cm interspace.
- Machine cannot be exposed to heat source and steam device directly. (such as steamer, dish-washing machine or stove)

Assure enough space to replace the easy worn spare parts.

4.3 Installation steps

Ink cartridge installation steps:

Remove the cartridge clip (be sure to keep the clip), pinch the end of the cartridge, and insert the cartridge nozzle along the track into the printer.

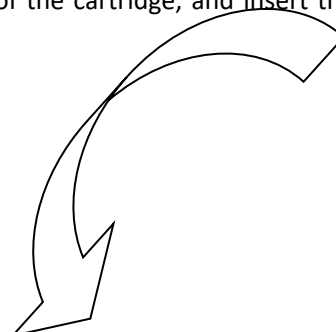

Aim the nozzle of the ink cartridge at the nozzle hole of the printer, push the ink cartridge forward, and the ink cartridge will pour down along the slope above the marbles.

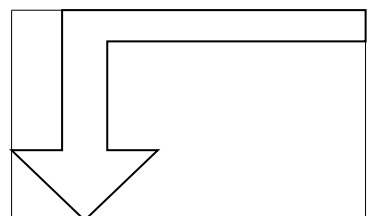

Press down on the tail of the ink cartridge and hear the sound of marbles. The nozzle of the ink cartridge is aligned parallel to the hole of the inkjet printer head, and the ink cartridge is successfully inserted.



5. Startup and commissioning

5.1 controlling panel

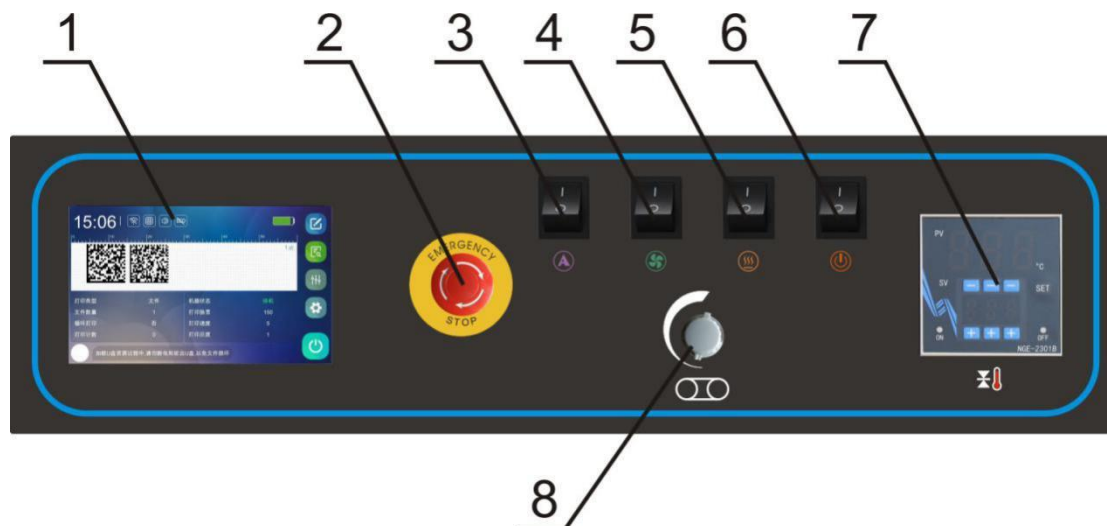

No.	Name	Description
1	Touch Screen for Inkjet Printing	Used to set the working parameters of the inkjet printer
2	Emergency Stop	For emergency stop, press the machine to stop running.
3	Printing Switch	Choose to turn on or off the coding function.
4	Fan	Open or close heat sealing / Open or close fan
5	Heat Sealing	Optional opening and closing heat sealing function.
6	Power	Used to turn on or off the machine power supply.
7	Temperature controller	Adjust the temperature of the heating block.
8	Knob	Adjust the motor speed, can make the sealing speed up or down.

5.2 Power on

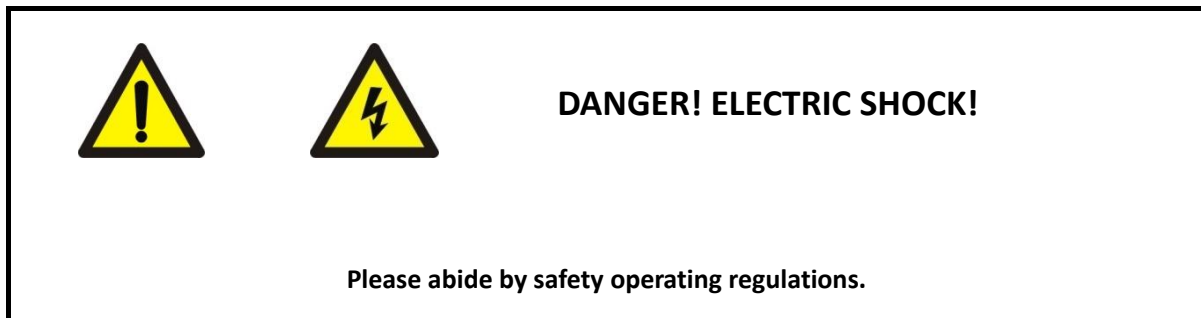

- Via rotating the Power Switch to start the machine.
- After the connection with the power supply, the indicator light will be on. And the touch display will show the home page, which means the machine is now in the state of standby, and the machine is ready to be operated.

5.2.1 Power connection

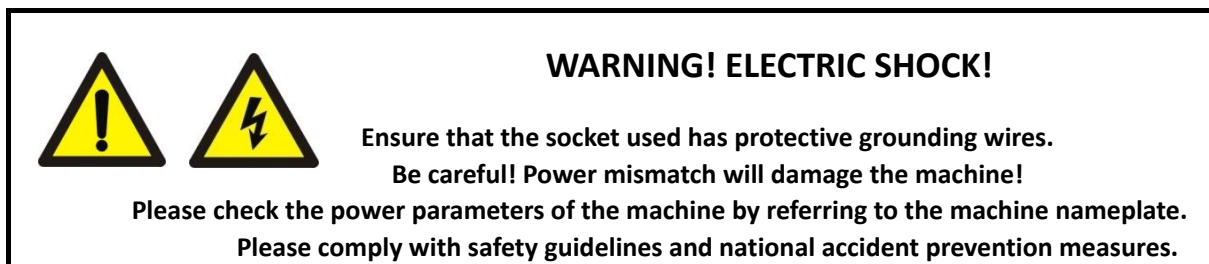

Power/Ground

- Check whether the power supply voltage is consistent with the voltage in the machine's nameplate.
- Ensure the machine is properly connected to a grounded receptacle, so as to avoid the fire or electric shock (grounding line is the yellow green double color line).
- The cable must be free to move to avoid extrusion.
- Once the cable is damaged, please replace immediately.
- When there is machine malfunction or when the machine needs maintenance, please cut off power supply.
- If the machine will be idle for a period, please pack the cable.

5.2.2 Startup procedure

- Connect the power and press the start switch, the indicator lights up, adjust the speed control knob, then the transmission parts run synchronously.
- Fine tune printing wheel knob, make the printing wheel rotating. Adjust it to the appropriate pressure and fix the limit screw.
- Turn on the heater switch, then the green light of temperature controller lights up. According to the material and thickness of the packing bag, adjust the temperature controller to the desired temperature. When the heating block begins to warm up, the machine shall be turned on at the same time.
- That whether it is necessary to turn on the fan for cooling depends on the material and thickness of packing bag.
- Flatten and align sealing opening, then feed the bag by aligning the bag opening with the feed opening. When the bag opening is gripped by the sealing belts, which makes the bag moving forward automatically, at that moment, please do not push it in or pull it out by force, otherwise there will be irregular sealing or breakdown.
- If it is found that there is dirt attached to the sealing belt or the heating block, stop the sealer and clear it. Do not clear the dirt with hands when the temperature is high

5.2.3 Stop operation

In order to prolong the service life of the sealer, before turning off the machine, please return the temperature-regulating knob to position 0 firstly, and turn on the fan. At the same time, the indicating temperature begins to fall and the sealing belt should still be in state of running. After several minutes later, when the temperature drops below 100°C, it is allowed to turn off the fan and main power switch.

5.2.4 Emergency stop switch

At any time, the machine stops immediately after pressing the emergency stop switch. The emergency stop switch is a self-locking switch, and it needs to be rotated by a clockwise 120 degrees to open.

5.3 Commissioning

5.3.1 Replacement and adjustment of the sealing belt

- Remove the safety cover, after the heating block cooling, rotate retaining washer by 90° on both upper heating block and upper cooling block to lift both two blocks, then loosen the springs on both embossing roller and pinch roller, meanwhile, remove the guiding belt, to make it ready for removing sealing belts (as below figure).

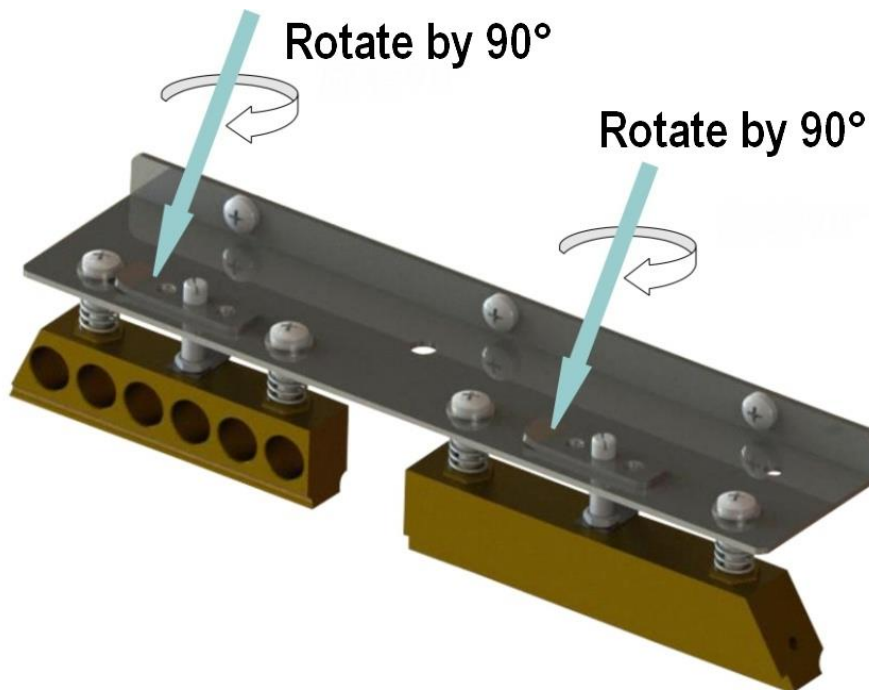

- Move the driven wheel seat (adjusting block) towards heating block, and remove the sealing belt.
- Replace it with a new sealing belt and install the guiding belt back.
- Adjust the driven wheel, heating blocks, cooling blocks, and pinch roller etc. to the original position.
- Connect the power supply to test the machine.
- Install the protection cover. When the temperature reaches the setting temperature, the machine is ready for work.

5.3.2 Forward-and-backward adjustment of conveyor table

Loosen the adjusting knobs on both sides first, and then move the conveyor table forward or backward in the long slot along the feet. Tighten the knobs on both sides after finishing the adjustment.

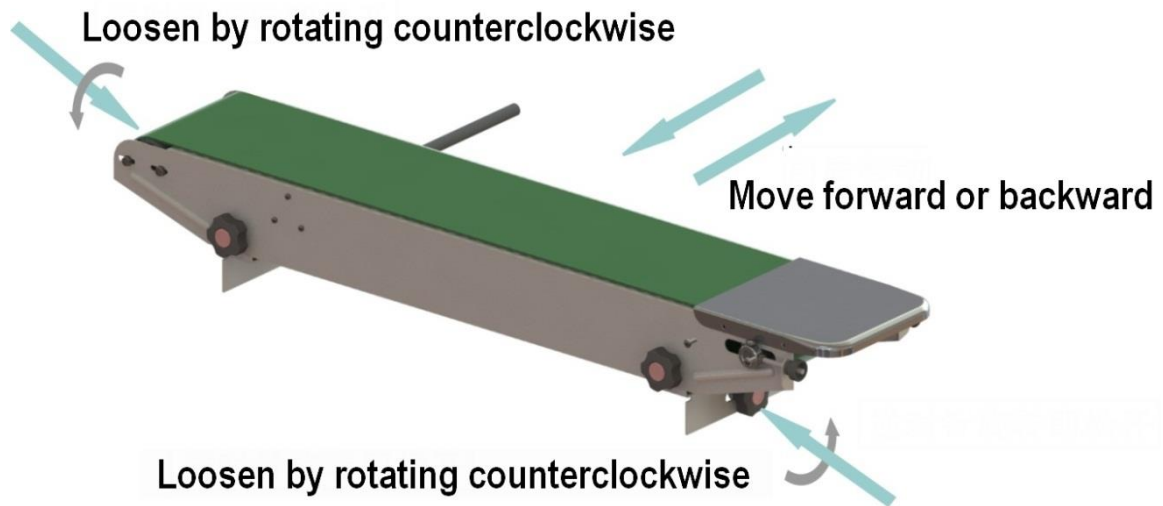

5.3.3 Adjustment of sealing belt deviation

If the sealing belt deviates, the sealing belt can be adjusted by adjusting the screws in the driven wheel seat (adjusting block) (as below figure).



5.3.4 Adjustment of conveyor table height

According to different materials, if it is needed to adjust the height of the conveying table, adjust the conveying table height by the adjusting knob in front of the conveyor table (as below figure), and tighten it after adjustment.



Loosen counterclockwise to adjust conveyor table height.

5.3.5 Adjustment of conveyor belt deviation

If the conveyor belt deviates, the conveyor belt can be adjusted by adjusting screws in the right side of conveyor table (as below figure). Keep the conveyor belt under tension state when adjusting, and it is not allowed to adjust when the conveyor belt under relaxed state.

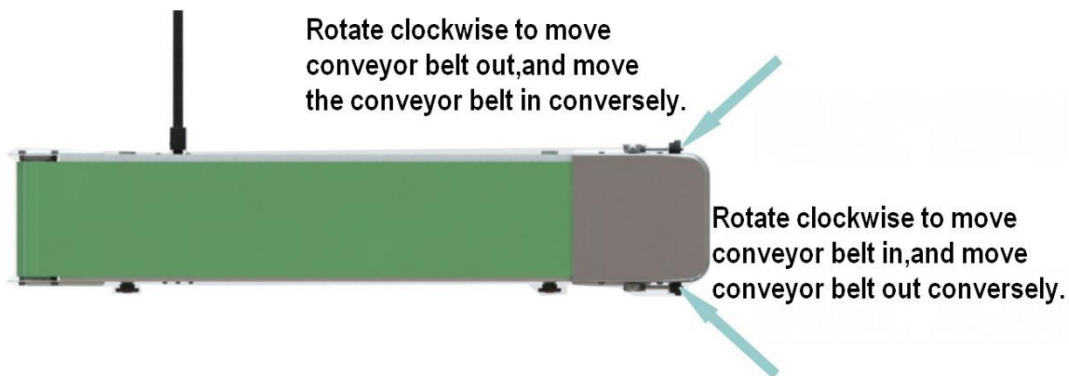

5.3.6 Pressure adjustment of embossing wheel

If there is a need to make the pattern of the embossing wheel deep or shallow, adjust the adjustment knob at the top of the embossing wheel (as below figure).





6. Standard Operation & Parameter Setting





TAKE CARE! INJURED!

Please refer to this manual to operate this machine.
It is not allowed to discharge the necessary protection cover or hull.



TAKE CARE! CLAMPED!

When the machine is running, it is forbidden to put hands into the driving wheel to avoid clamping hands!



TAKE CARE! SCALD!

When sealing, the temperature outside the surface of heating block can reach over 200°C.
Even after cooling, it is still with high temperature.

- If any question about operation and function of the machine, when related information is not included in this manual, please contact manufacturer or distributor.
- If machine is not running in normal situation or produces strange noise, please turn off power immediately to stop machine running and cut off power supply.
- Once in trouble, please contact manufacturer or distributor.

6.1 Preparation, adjustment and inspection before operation

- This machine is equipped with a grounded three-hole socket. The power supply used should be well grounded to ensure safety in production.
- **Before use, you need to check the cartridge chip and metal sheet for residual ink. If there is ink, it needs to be cleaned or it will burn out the jetty.**
- **It is recommended to test the ink condition by placing a piece of white paper under the ink cartridge before it is inked.**
- When in first time use or when there is too long time interval after use, the electric heating element will be affected with damp, it should be operated in normal operation after preheating in low temperature for a few minutes.
- According to the bag shape and size, adjust the conveying table height and forward-and-backward position.
- According to the shape and size of the sealing line to the mouth, adjust the position (inlet).
- According to thickness of the sealing material, adjust upper and lower heating blocks, and the clearance between upper and lower cooling blocks, adjust the pressing force of retaining washer to control the clearance between the two sealing tapes, adjust clockwise to lift (increase clearance) and counterclockwise to fall (narrow clearance). The clearance between two sealing belts is equal to about the thickness of one layer of packing bags, so that the sealing fastness and embossing sharpness of the bag can be ensured and the clearance between two ends of the seal are not too long.

6.2 Parameter Setting



TAKE CARE! DAMAGE!

Unreasonable parameter setting may damage machine or shorten machine service time.

- Unreasonable parameter setting may damage the machine or shorten the service time.
- Unreasonable parameter setting may cause all procedures or sealing not to be completed correctly.
- If any question about machine's operation or function of the machine, please contact the manufacturer or distributor.
- **Speed Parameter Setting**
- There is a speed adjusting knob in the control panel to adjust the sealing speed, clockwise rotation is to increase the sealing speed, counterclockwise rotation is to reduce the sealing speed.
- **Optimal Parameter**
- The distance between bag sealing center to the edge of the bag is 10 ~ 20 mm.
- Bag sealing quality is determined by the three elements of heat sealing temperature, sealing speed and pressure.
- Temperature setting should be adjusted slowly from low to high according to the thickness of the bag.
- Speed setting should be adjusted slowly from slow to fast according to the sealing effect.

The sealing pressure is adjusted to appropriate pressure before the machine leaving factory, and it is suitable for most product bags. If after adjusting temperature and speed, the bags cannot get the ideal sealing effect, please adjust the belt-pressing wheel to make pressure change from low to high slowly so that to get the expected sealing effect.

Common material heat-sealing temperature reference table

Material Name	Thickness (μm)	Recommended temperature setting ($^{\circ}\text{C}$)	Heat-sealing speed (m/min)
LDPE	30~160	105~150	6~10
MDPE	40~120	115~120	7.2~10.2
HDPE	40~90	125~150	7.2~10.2
PP	40~60	135~160	7.2~10.2

6.3 Menu

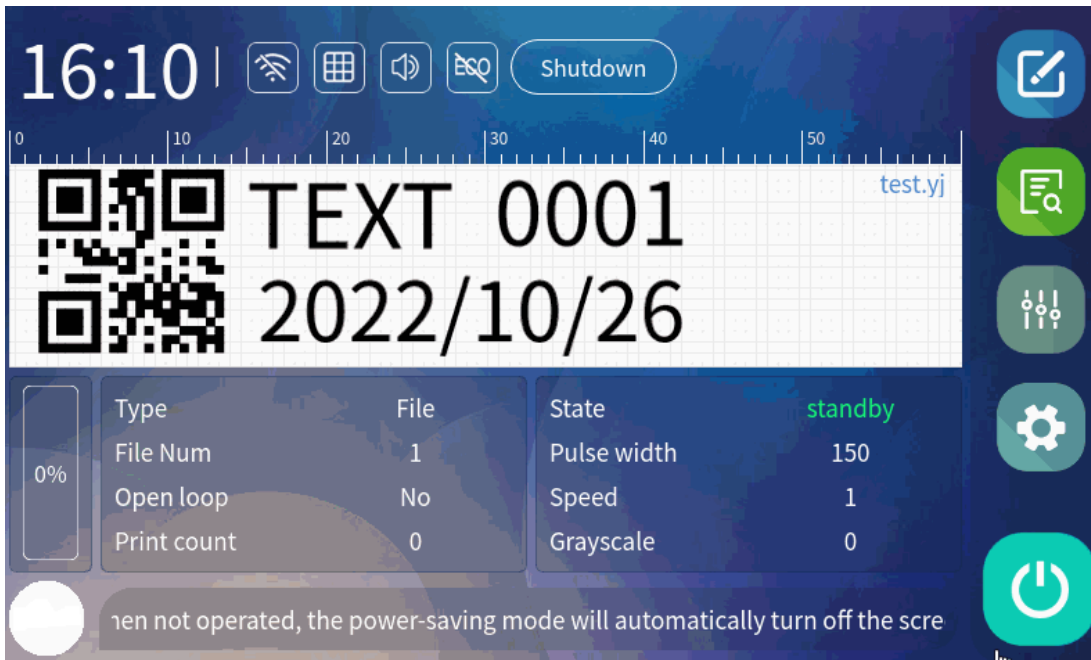

1.The first line: display the current system time and function

2. Display text content length and height scale

3. The current print information and its file name

4. Type:display a single file or a group of files in printing

5. File Num:show how many files are in the printing information

6. Open loop: display whether the group file is cyclically printed

7. Print count: display the number of times the text was printed

8. State: show that the machine is in standby or printing





9. Pulse width:display the set print pulse width value

10. Speed:display the set printing speed value

11. Grayscale:display the set print grayscale value

12. Display area of small tips for machine use



13. File editing: click to edit a new file

-
14.  File selection: click to select the internal file saved in the machine
 15.  Advanced options: setting of machine general and printing parameters
 16.  Setting: general and printing parameters settings of the machine
 17.  Start printing: After the ink cartridge is installed, click this button to print (note: do not insert or remove the ink cartridge when printing); when printing is not required, click this button to stop working.

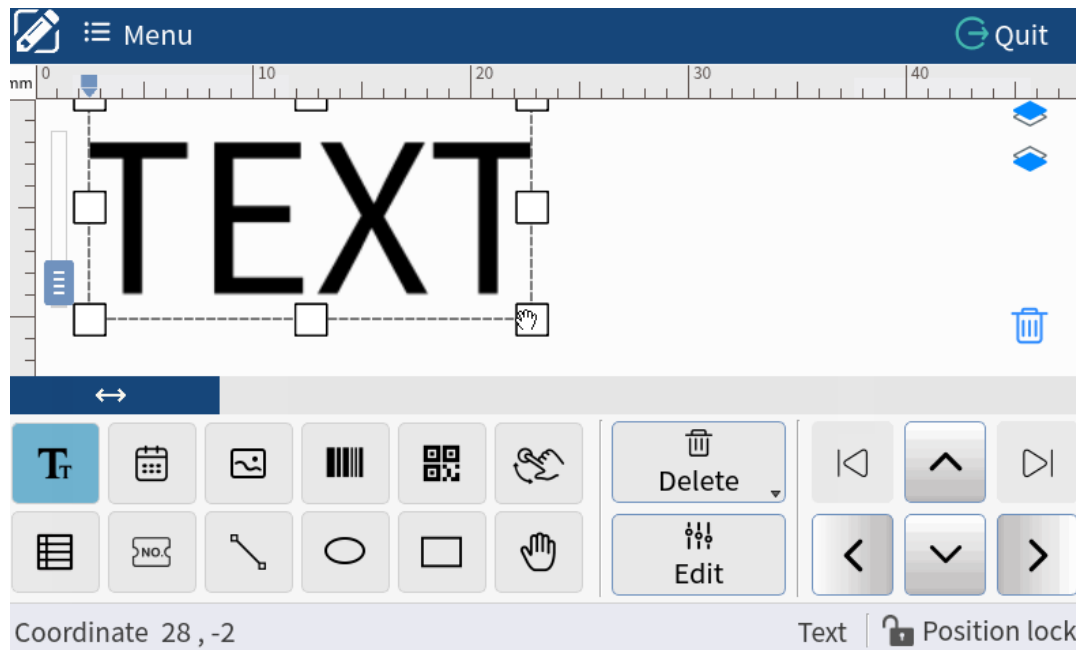
6.4 File Edit

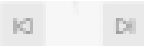

1. Add fixed text content
2. Add variable date and time
3. add pictures
4. Add barcode
5. Add a QR code
6. Rotate selected objects (fields or graphics)
7. Add table
8. Add serial number counter
9. Add line segment
10. Add a circle or ellipse
11. Add rectangle
12. Move or zoom the selected object
13. 删除 Delete a single selected object or clear information
14. 编辑 Edit and modify the selected object

-
15.  Fine-tune the selected object up, down, left, and right
 16.  When there are multiple field objects in the information area, switch the selected field object
 17.  Click this button to save information, create new information or modify saved information

6.5 Preview

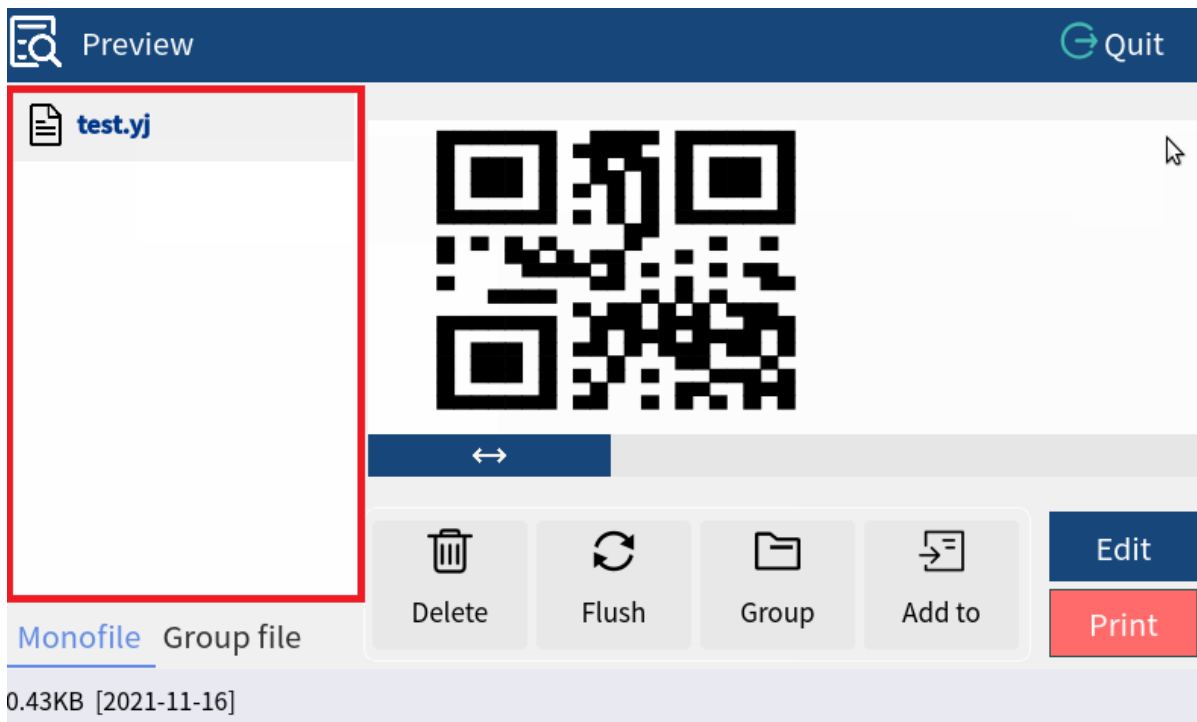



1. The file name of the saved information is displayed in the red solid line frame. You can click the file name to preview the file content, edit the file content or print the selected file

2.  Display the information content under the current file name

3.  Delete Delete selected files

4.  Refresh the information content

5.  Create group file

6.  Add the selected single file to the group file

7.  Edit and modify the selected single file

8.  Print the selected single file or group file

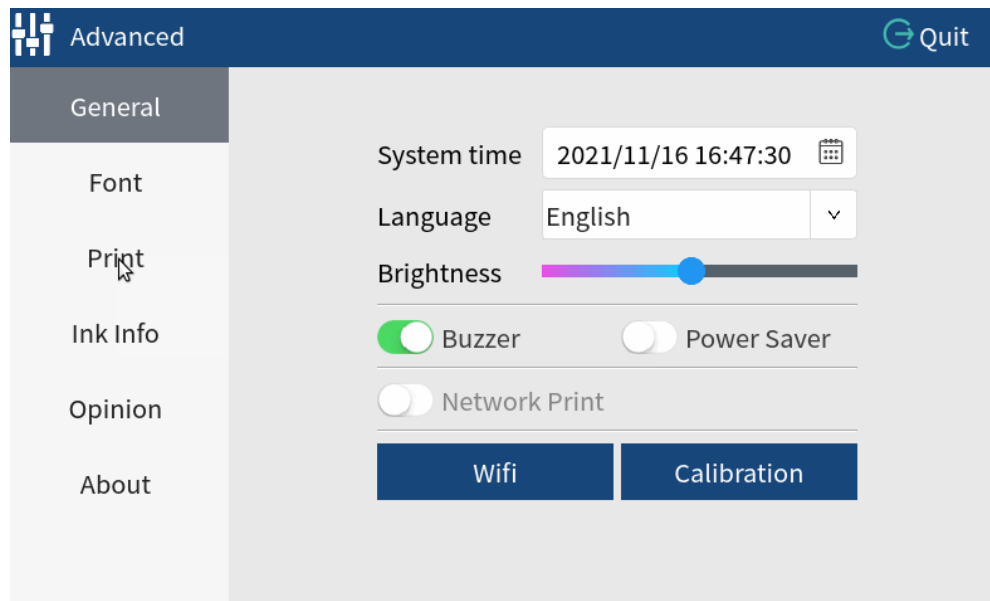

6.6 Advanced

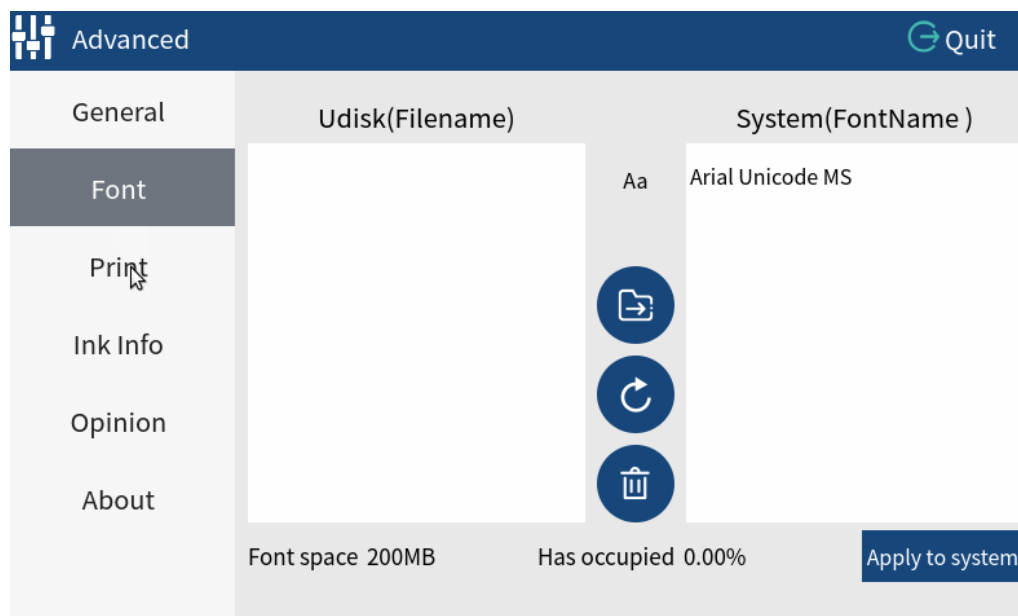

1. System time: adjust the current system year, month, day, hour, minute, and second
2. Language: select the desired language
3. Brightness: adjust the brightness of the screen backlight
4. Buzzer: when you select the ON state, there will be a "di" sound at the beginning and end of printing; if it is not turned on, there will be no sound when printing
5. Power Saver: when the on state is selected, the machine will automatically reduce the brightness of the screen after no operation to protect the life of the screen; otherwise, it will not
6. Calibration: when the touch screen is not sensitive, you can enter the screen calibration for calibration



When you need to print fonts that are not in the system, you can copy them on this page

 Advanced
 Quit

General	Direction	forward	▼	Inkjet mode	left	▼
Font	Trigger	electric eye	▼	Pulse width	— 110	+
Print	Source	built-in	▼	Frequency dou	— 0	+
Ink Info	Speed	— 16	+	Frequency	— 0	+
Opinion	Delay	— 22	+	Interval time	— 0	+
About	Grayscale	— 1	+	<input type="checkbox"/> Sync-wheel		
	Voltage	— 9	+			

1.Direction: the direction in which the font is printed, forward, reverse, forward and backward, reverse direction can be selected

2.Inkjet mode:The cartridge has two nozzles, you can choose to spray left or right

3.Trigger: electric eye

4.Speed: the faster the bag moves, the smaller the print speed value is set

5.Delay: the larger the delay, the later the printing position will be after the sensor is inducted, the smaller the delay, the forward the printing position



6.Grayscale:Print gray scale: adjustable font depth, the larger the number, the darker the color(No more than 2 is recommended)

7.Pulse width: recommended to be set to 110-150

8.Voltage: recommended to be set to 9

9.Sync-wheel: close this button

7. Maintenance



Alarm ! Electric Shock !

The power of the machine should be fully cut off before maintenance.

Daily maintenance to the machine is necessary to lengthen the service life of the machine and to achieve best packing effect. If the machine is frequently used (more than four hours per day), it is suggested to do professional maintenance every three month. If the machine is used less than four hours per day, it is advisable to do comprehensive maintenance very six month (according to place, environment and product). However, some users could do simple following maintenance to the machine according to their practical needs.

7.1 Attention for maintenance

- The power of the machine should be fully cut off, the power cord should be pulled out from the socket in the wall.
- If the machine runs incorrectly or there is some abnormal noise during operation, please immediately turn off the power and contact supplier or manufacturer.
- Please do not wash the machine with high pressure washer which will do much damage to the electronic components and other spare parts in the machine.
- Please do not let the water flow into the control panel, or it will do damage to the electric circuit.
- Power off the machine before installing or removing the ink cartridge. Otherwise, the ink cartridge may be burned.
- Do not squeeze, hit, or drop the ink cartridge. If the ink cartridge is scratched or knocked, it may be unavailable.
- If the operator's maintenance to the machine is not according to this manual, the manufacturer will not take responsibility for any failure or damage of the machine.

7.2 Maintenance period table

Schedule	Contents of Maintenance
Daily	<ol style="list-style-type: none"> 1. Use the brush to remove the substance attached to the appearance of the sealing belt and guiding belt. 2. Use wet cloth to clean the appearance of the conveyor belt. 3. When not using the machine for more than 20 minutes, please remove the ink cartridge from the machine and cover it with a special clip.
Monthly	<ol style="list-style-type: none"> 1. Check whether the sealing belt is worn or not 2. Check whether the guiding belt is worn or not 3. Clean the carbon brush of the motor
Half a year	<ol style="list-style-type: none"> 1. Check the worn situation of the carbon brush of the motor which is suggested to change once a year 2. Adding lubricating grease to the gears which are exposed without cover.
Yearly	<ol style="list-style-type: none"> 1. Comprehensively check the machines according to above items. 2. Check whether the rubber wheel is aging or not, aged rubber wheel is better to be replaced. 3. Check whether the temperature controller could reach the temperature value set within ten minutes or not. If it could not reach the set temperature within ten minutes, the temperature controller should be replaced. 4. Check whether the electronic parts including emergency switch, buttons, potentiometer, fan and so on work normally or not. 5. Check and add lubricating grease to the transmission parts including gears, shafts and joints. If there are any worn seriously among these parts, it is necessary to change them. 6. Clean the Worm-gear case and change the oil in it. If filtering the oil in the Worm-gear case twice, and the oil is still not clear, then the lubricating oil must be changed.

8. Troubleshooting

8.1 Troubleshooting

Problem	Reason	Solution
The machine does not work	<ol style="list-style-type: none"> 1. The power is not connected. 2. The fuse is broken or high resolution circuit breaker trips. 3. The emergency stop switch is pressed but there is no reset. 	<ol style="list-style-type: none"> 1. Check the electric outlet. 2. Replace the fuse and high circuit breaker. 3. Reset the emergency stop switch.
Conveyor belt is off-tracking.	<ol style="list-style-type: none"> 1. The active axle is not parallel to the driven axle. 	<ol style="list-style-type: none"> 1. Adjust two adjusting screws of Driven Wheel Seat.
Sealing belt is easily broken.	<ol style="list-style-type: none"> 1. Too much tension on sealing belt. 2. Sealing belt is off tracking. 3. Crease on sealing belt. 4. Adhesive film or other dirt attached to sealing belt surface. 5. Sealing belt is easy to be scorched. 	<ol style="list-style-type: none"> 1. Adjust the vertical adjusting screw on driven wheel seat, so as to make sealing belt neither too tight nor too loose. 2. (see the point above) . 3. No crease on sealing belt. 4. Clean the surface of sealing belt in time 5. Clearance between two heating blocks is too small or temperature is too high.
Embossing is not clear.	<ol style="list-style-type: none"> 1. Embossing wheel is worn out. 2. Pressing spring on embossing wheel is not tightened enough. 	<ol style="list-style-type: none"> 1. Replace embossing wheel. 2. Adjust the tightening spring of embossing wheel.
There is resistance when the sealing belt is conveying.	<ol style="list-style-type: none"> 1. The clearance between heating blocks or cooling blocks is too small, the friction is too much. 	<ol style="list-style-type: none"> 1. Adjust the clearance between sealing belts properly, which should be about thickness of packing bag in one layer, to ensure strong sealing and clear printing, but not make the two ends of sealing part extend too long.
There is block or fold phenomenon when the packing bag is conveyed to middle pressing wheel or embossing wheel.	<ol style="list-style-type: none"> 1. Too much pressure caused by pressing wheel or embossing wheel. 	<ol style="list-style-type: none"> 1. Adjust the pressing wheel or embossing wheel to proper pressure, to make the clearance between two sealing belts be about thickness of packing bag in one layer. So that not only ensure the strong sealing and clear printing, but not make the two ends of sealing part extend too long. 2. Adjust limiting screw after adjusting clearance.
Conveyor belt is off-tracking.	<ol style="list-style-type: none"> 1. The active roller shaft is not parallel to the driven roller shaft 	<ol style="list-style-type: none"> 1. Adjust the two adjusting screws of the driven roller shaft (rear axle).
Conveyor belt and sealing belt don't move synchronously.	<ol style="list-style-type: none"> 1. The conveyor belt is not tight. 	<ol style="list-style-type: none"> 1. Tighten the chain of driving roller shaft (front shaft) and middle shaft properly. 2. Tighten the conveyor belt properly.
The noise in the gear box increases	<ol style="list-style-type: none"> 1. The lubricating oil of worm gear box needs to be changed. 	<ol style="list-style-type: none"> 1. Use Great Wall 000# super pressure lithium grease.

Problem	Reason	Solution
Touch screen is out of order. Nothing happens when you click the screen	1. You need to recalibrate the screen.	1. ① Insert the mouse into the USB port on the side of the case; ② Click the mouse to enter the advanced option -- General -- screen calibration; ③ When the screen restarts, pull out the mouse, and then the screen will enter the calibration interface. Click the anchor point on the screen successively, and click 5 times to complete the calibration of the screen.
Incomplete printing, printing appears to be missing the upper or lower part of the print	1. The portal chip of the ink cartridge should not have ink marks, otherwise it may cause some contacts to burn out, resulting in some nozzle of the ink cartridge can not work. 2. Part of the pin in the jetty did not pop out, resulting in the nozzle of the ink cartridge not working. 3. Part of the ink cartridge nozzle is blocked.	1. Check whether the gate chip of the ink cartridge has ink marks. 2. Check whether part of the pin in the jetty does not pop out. 3. Adjust the printing pulse width in the touch screen parameter setting page to 150 (if it is winter, the printing voltage can be adjusted to 12V if the printing voltage is low).
The print is not black, and there is scattered ink next to it	1. The distance between the bag and the jetty is too large. 2. The ink in the cartridge is running out.	1. Check the distance of the guide plate below the jetty, and the jetty is within 5mm of the guide plate. Beyond this distance, the printed word will be pale in color, with scattered ink around the font. 2. The print font is not black before use will not appear, in the ink cartridge will be used up. Adjust the print gray value in the parameter setting interface, the larger the value, the more black the word, the larger the ink printing machine. After adjusting the gray font will become longer, and need to adjust the print speed value set small. (Adjust the gray value must adjust the printing speed).
When customers adjust the sealing speed, they find that the font length changes and the kerning also changes.	1. This is a normal phenomenon, you can set the parameters to solve.	1. If the customer proposes that the printed word is too long and not compact in the sealing process, it is necessary to adjust the printing speed in the parameter setting interface to a smaller value. On the contrary, the customer feels that the printing word is too short and crowded together, so the printing speed in the parameter setting interface is adjusted to a larger value. 2. The font height change of the injet machine is to adjust the appropriate height when editing the content and then printing. The printing height can not be solved by adjusting the printing speed,



Problem	Reason	Solution
		but can only be adjusted by adjusting the font size.
In the process of inkjet printing, the main interface prints count hops, but no words can be sprayed	<ol style="list-style-type: none"> 1. The printed content is empty. 2. The ink cartridge contact is poor or the ink cartridge is not inserted in place. 3. The printing delay setting in the touch screen parameter setting page is too large or too small, resulting in the actual action of the inkjet, but did not hit the bag. 	<ol style="list-style-type: none"> 1. Whether the printed content is edited, and whether the printed content is visible on the main interface. 2. Check whether the cartridge is inserted properly. 3. Adjust the printing delay time in the screen parameter setting page.
In the process of jet code printing, the word can not be sprayed out, and the print count of the main interface does not jump	<ol style="list-style-type: none"> 1. The trigger mode in the touch screen parameter setting page is not external electric eye. Please note that it should be set as external electric eye. 2. The synchronization wheel in the touch screen parameter setting page is open, and please note that the synchronization wheel should be closed. 3. The wiring fault between the spray wharf and the touch screen may be that the wiring is not inserted firmly or inserted backwards. 4. The spray wharf photoelectric is blocked by the lower guide plate, resulting in photoelectric failure. 5. Before the sealing machine inlet baffle is adjusted, the photoelectric can not shine on the bag. 	<ol style="list-style-type: none"> 1. Check whether the trigger mode on the parameter setting page of the touch screen is external electric eye. 2. Check whether the synchronization wheel is closed on the parameter setting page of the touch screen. 3. Check whether the wiring connecting the spray dock and the touch screen is inserted firmly or not. 4. Check whether the guide plate is blocked to photoelectric. 5. Check whether the position of the sealing machine inlet baffle is wrong.



<p>The jetty is burnt out</p>	<ol style="list-style-type: none"> 1. Live plugging ink cartridge will cause the contact piece to touch the two contacts, which will cause short circuit. 2. When the cartridge is removed for preservation or other operations, the touch piece is stained with ink, resulting in short circuit when it is installed and printed again. 	<ol style="list-style-type: none"> 1. The customer must insert and remove the ink cartridge in the case of power failure. 2. Before loading the ink cartridge, ensure that the ink cartridge door font chip is clean and no ink residue remains.
<p>After a few hundred prints, the machine stops printing and can be restarted to print again</p>	<ol style="list-style-type: none"> 1. The machine has no ground wire, or the ground wire is impassable, and the instantaneous current will cause the program to stop. 2. In the process of machine operation due to the material of packaging materials, the instantaneous static electricity will cause the program to stop. 	<ol style="list-style-type: none"> 1. the machine needs to be effectively grounded. 2. The occasional printing stop requires the guest to restart the system.

8.2 Motor maintenance

(1) Stop and check the machine when any abnormal occurs to motor, do not use the machine until problem is solved.

(2) Dedust and clean motor regularly. Ethyl alcohol, gasoline and liquid with benzene chemicals should be avoided, otherwise it will affect the paint of motor cover.

(3) Carbon brush is designed to be used 2500 hours continuously and commutator 2500 hours. The toner on the internal of motor and surface of commutator should be cleaned every 120 hours after use. The commutator should be wiped by ethyl alcohol. Replace carbon brush and commutator immediately when they were worn out.

(4) The motor should be used indoors under normal atmospheric temperature to avoid friction, exposure to rain, and chemical corrosion, etc.. Please contact the supplier or manufacturer first if the motor is to be used in bad condition (such as exposure to Corrosive atmosphere, temperature higher than 30°C or lower than 5°C).

9. Storage

9.1 Storage of short time

- Turn off the power button, unplug the power cord, pack up the power cord.
- Clean the dust.
- If possible, cover it with the plastic bag to keep it from dust.
- Store it in a dry, dust-free and shockproof room.
- When not using the machine for more than 20 minutes, please remove the ink cartridge from the machine and cover it with a special clip to prevent the nozzle from being exposed to the air for a long time and causing the nozzle to block.(be sure to keep the clip)

9.2 Storage of long time

- When the machine leaves the factory, it has been dealt with necessary anti-rust treatment, so there is no need to add more preservative oil to the machine. If the condition of the storage is poor(the surrounding environment is corrosive, higher or frequently changing temperature),it is suitable to add more preservative oil to the machine. If there is any question, please feel free to contact supplier or manufacturer.
- Turn off the power button, unplug the power cord, pack up the power cord.
- Clean the dust.
- cover it with the plastic bag to keep it from dust.
- If possible, please pack it as original.
- Store it in a dry, dust-free and shockproof room.

9.3 Start the machine after long-term storage

Please refer to the instruction of “Installation and Start” in this manual.

10. Electric schematic diagram

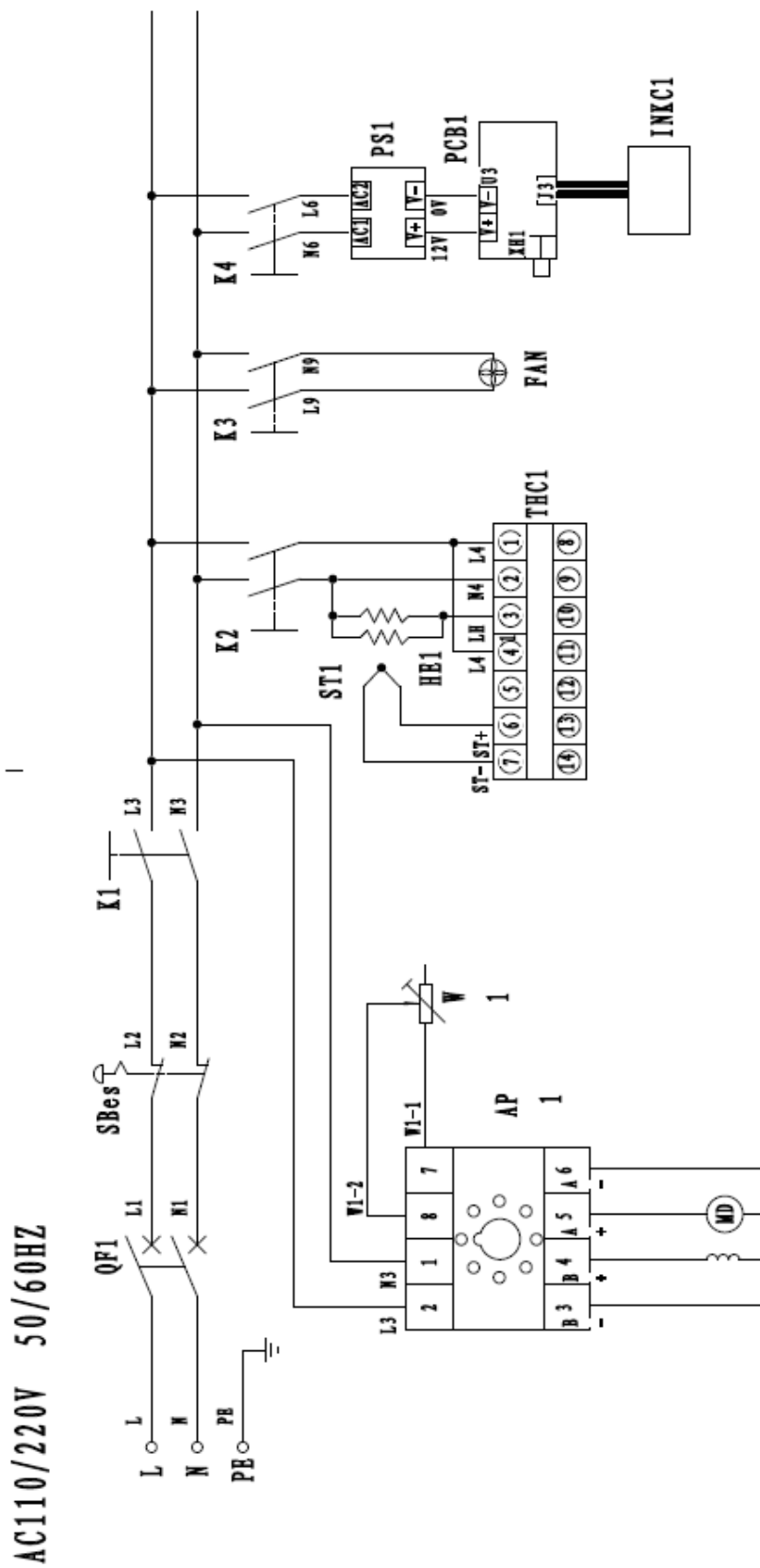

QF1-Break SBes-Emergency stop switch K1-Power switch K2-Heat switch K3-Fan switch K4-Inkjet switch
 W1-Speed adjustment HE1-Heat sealing heating pipe MD-Motor FAN-Fan THC1-Heat seal temperature controller ST1-Thermocouple
 AP1-Governor board PS1-Switching mode power supply PCB1-Inkjet control circuit board INKC1-Ink cartridge

11. Parts Diagrams

11.1 Sealing part 1:

serial number	ERP	name	quantity	unit	Remark
1-1	11271020500	Fully enclosed upper guard	1	individual	
1-2	9425100020672	wide angle belt	1	individual	
1-3	9425100020600	wide angle belt	1	individual	
1-4	11271020600	Fully enclosed lower guard	1	individual	
1-5	11111030004	Embossed wheel seat	1	individual	
1-6	A111110307 square bearing housing assembly	9105200602011 deep groove ball bearing	2	individual	6201 2Z
1-7		Square bearing	1	individual	
1-8	11111030003B	Embossing wheel	1	individual	
1-9	11211030028	rubber axle	1	individual	
1-10	11111030100	Rubber wheel assembly	1	individual	
1-11	9746016400032	retaining ring for hole	1	individual	Φ 32mm
1-12	9105200602011	Deep Groove Ball Bearings	1	individual	6201 2Z
1-13	11111030018	rubber wheel cover	1	individual	
1-14	9746036400012	shaft retaining ring	2	individual	Φ12mm _
1-15	11111030022	Drive pulley shaft	2	individual	
1-16	11271030019	Drive pulley	2	individual	
1-17	A113110101	Universal joint assembly	1	individual	
1-18	11271040031	Fully enclosed lower guard struts	3	individual	
1-19	11311030002	tension pulley	1	individual	
1-20	11111030001	small pulley	3	individual	
1-21	9105200600062	Deep Groove Ball Bearings	4	individual	606-2Z
1-22	9746016400017	retaining ring for hole	4	individual	Φ17mm _
1-23	11271030002	small pulley shaft	4	individual	
1-24	9103101211060	driven wheel seat spring	1	individual	
1-25	11111030006	spring seat	1	individual	
1-26	11111030008	feet	1	individual	
1-27	9100402143052T	Five-star handle (casting)	1	individual	
1-28	11271090005	Inkjet printer guide plate	1	individual	
1-29	11271090010	jetting pad	1	individual	
1-30	9230210400017	Jetting terminal (for right-entry machine)	1	individual	
1-31	11271040600	case back cover	1	individual	
1-32	11111040015S	Door Latch	2	individual	

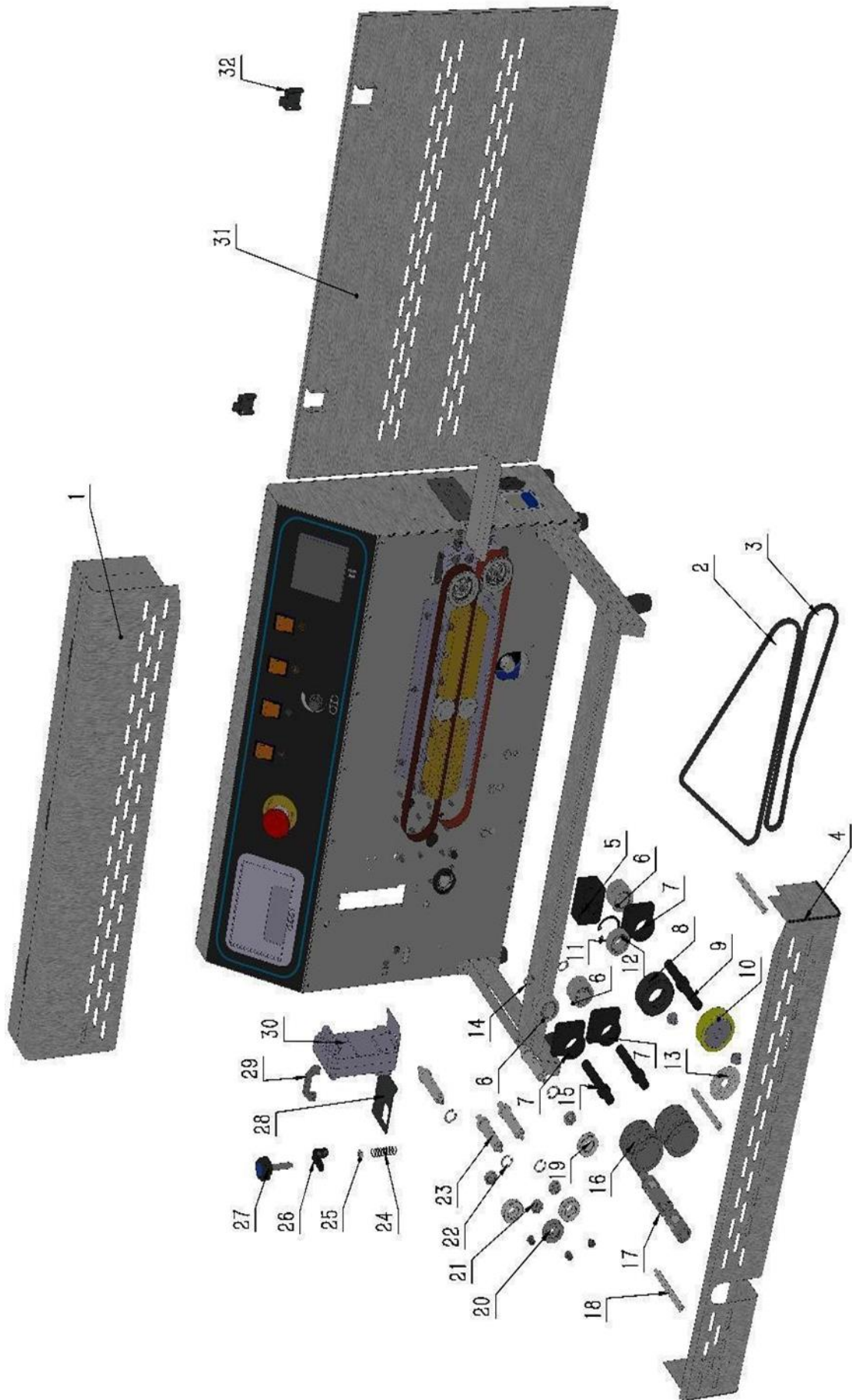

11.2 Sealing part 2 :

	ERP	name	quantity	unit	Remark
2-1	11271030039	Bottom plate	1	individual	
2-2	9103101211060	driven wheel seat spring	2	individual	
2-3	11311030029	Inlet	1	individual	
2-4	11101020016A	Compression torsion spring (upper)	1	individual	
2-5	11101020017AS	Tablet (on)	1	individual	
2-6	11101020017BS	Tablet (below)	1	individual	
2-7	11101020016B	Compression torsion spring (lower)	1	individual	
2-8	9241100010350	thermocouple	1	individual	
2-9	11111030042S	Thermocouple base plate	1	individual	
2-10	9240112123005	Heater	2	individual	
2-11	11111030200	driven wheel seat	2	individual	
2-12	A111110303 driven wheel assembly	9105200602012 deep groove ball bearing	2	individual	6201-2RS
2-13		9746016400032 retaining ring for holes	2	individual	Φ32mm
2-14		driven wheel	2	individual	
2-15	9161101113201S	upper heating block	1	individual	
2-16	9161101113201X	lower heating block	1	individual	
2-17	11111030031	copper pad	4	individual	
2-18	11311030036S	Lower pallet	1	individual	
2-19	9430113081015	sealing tape	2	individual	
2-20	11111030011	stop film	2	individual	
2-21	11311030012S	Upper pallet assembly	1	individual	
2-22	9103101010025S	copper block spring	5	individual	
2-23	9161100111001	Copper block spring seat	4	individual	
2-24	9161102113201S	upper cooling block	1	individual	
2-25	9161102113201X	lower cooling block	1	individual	
2-26	11111030014	Roller slider	1	individual	
2-27	11311030014	Upper roller shaft	1	individual	
2-28	9746016400026	retaining ring for hole	2	individual	Φ26mm
2-29	9105200601002	Deep Groove Ball Bearings	2	individual	6000-2Z



	ERP	name	quantity	unit	Remark
2-30	9746036400010	shaft retaining ring	2	individual	Φ10mm
2-31	11311030035	Pressure wheel	2	individual	
2-32	11311030034	Press down axle	1	individual	

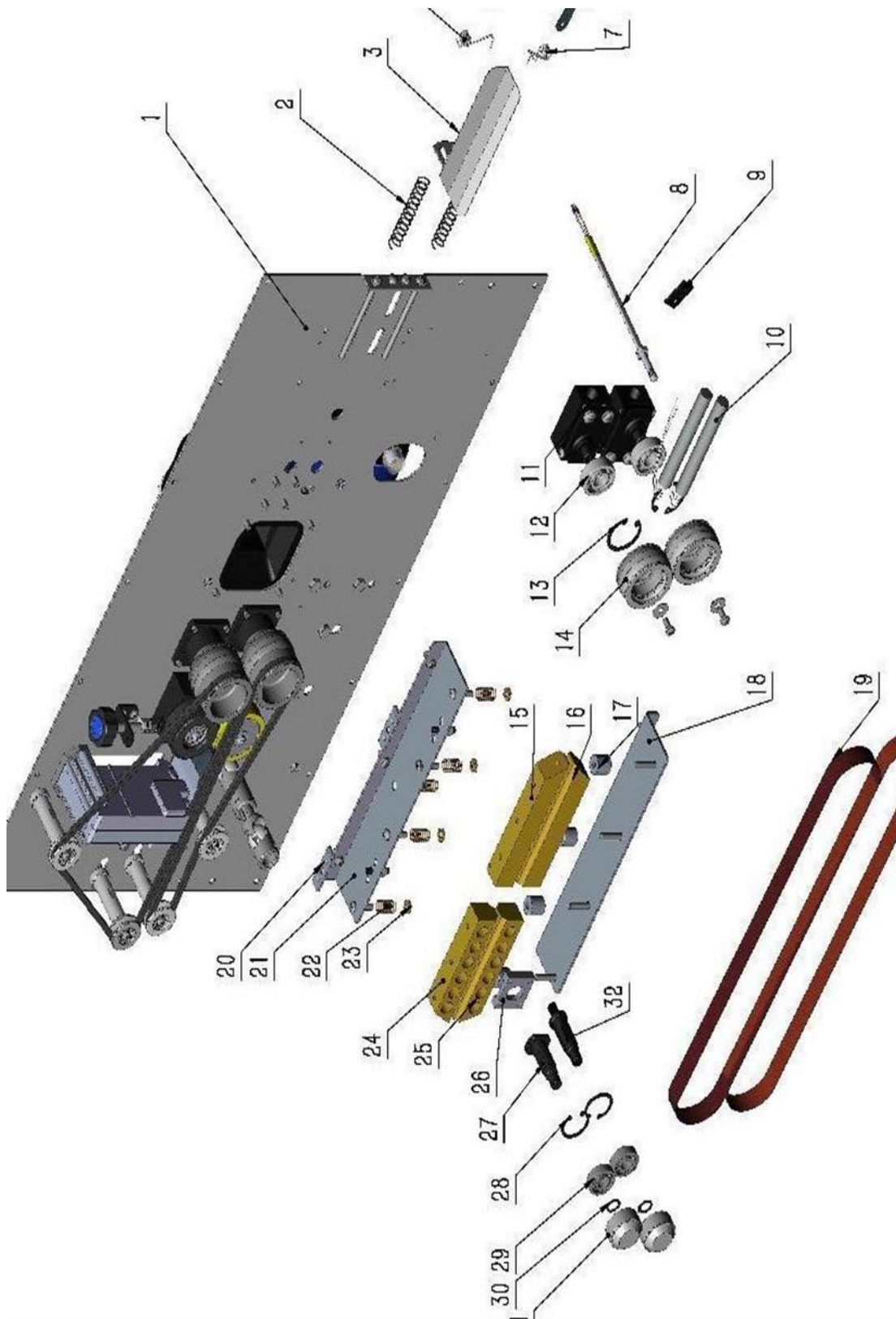

11.3 Sealing part 3

serial number	ERP	name	quantity	unit	Remark
3-1	11311030026	Connecting shaft bearing housing	1	individual	
3-2	9105200601012	Deep Groove Ball Bearings	2	individual	6001-2Z
3-3	11111030021-35	gear	4	individual	
3-4	11311030024	Intermediate gear shaft	1	individual	
3-5	9105200601982	Deep Groove Ball Bearings	1	individual	619/8-2Z
3-6	9746016400019	retaining ring for hole	1	individual	Φ19mm _
3-7	11311030023-20	Medium gear	1	individual	
3-8	9230121000635-1	fan	1	individual	
3-9	9201401125005	Terminals	1	individual	
3-10	Attached picture	Worm Gear Box Motor Assembly	1	individual	

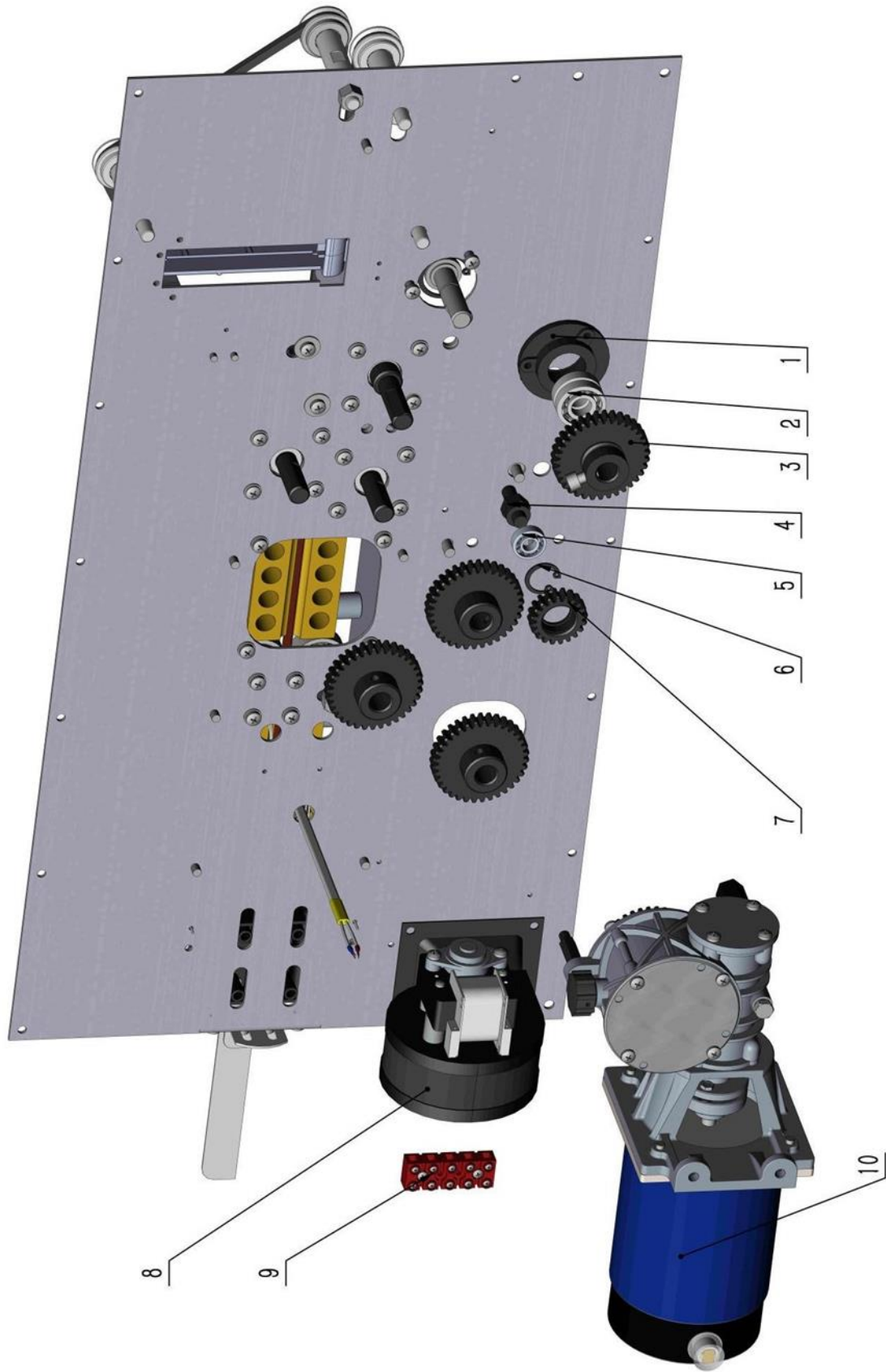

11.4 Worm gear box assembly

serial number	ERP	name	quantity	unit	Remark
4-1	11111050006	Worm gear box cover II	1	individual	
4-2	9412121002512	Skeleton oil seal	2	individual	
4-3	9105200602011	Deep Groove Ball Bearings	4	individual	6201 2Z
4-4	11271050008	Double shaft extension worm gear shaft	1	individual	
4-5	11111050001-2	worm shaft	1	individual	
4-6	11111050005-25	worm gear	1	individual	
4-7	11111050013	Worm cover	1	individual	
4-8	11111050011-25	Worm	1	individual	
4-9	11111050003	Worm gear box motor flange	1	individual	
4-10	11111050009	Coupling Half I	1	individual	
4-11	9412120009050T1	Coupling rubber ring on worm gear box	3	individual	
4-12	11111050010	Coupling Half II	1	individual	
4-13	11111050002	Worm gear box air cap	1	individual	
4-14	11111050004	Worm gear box cover I	1	individual	

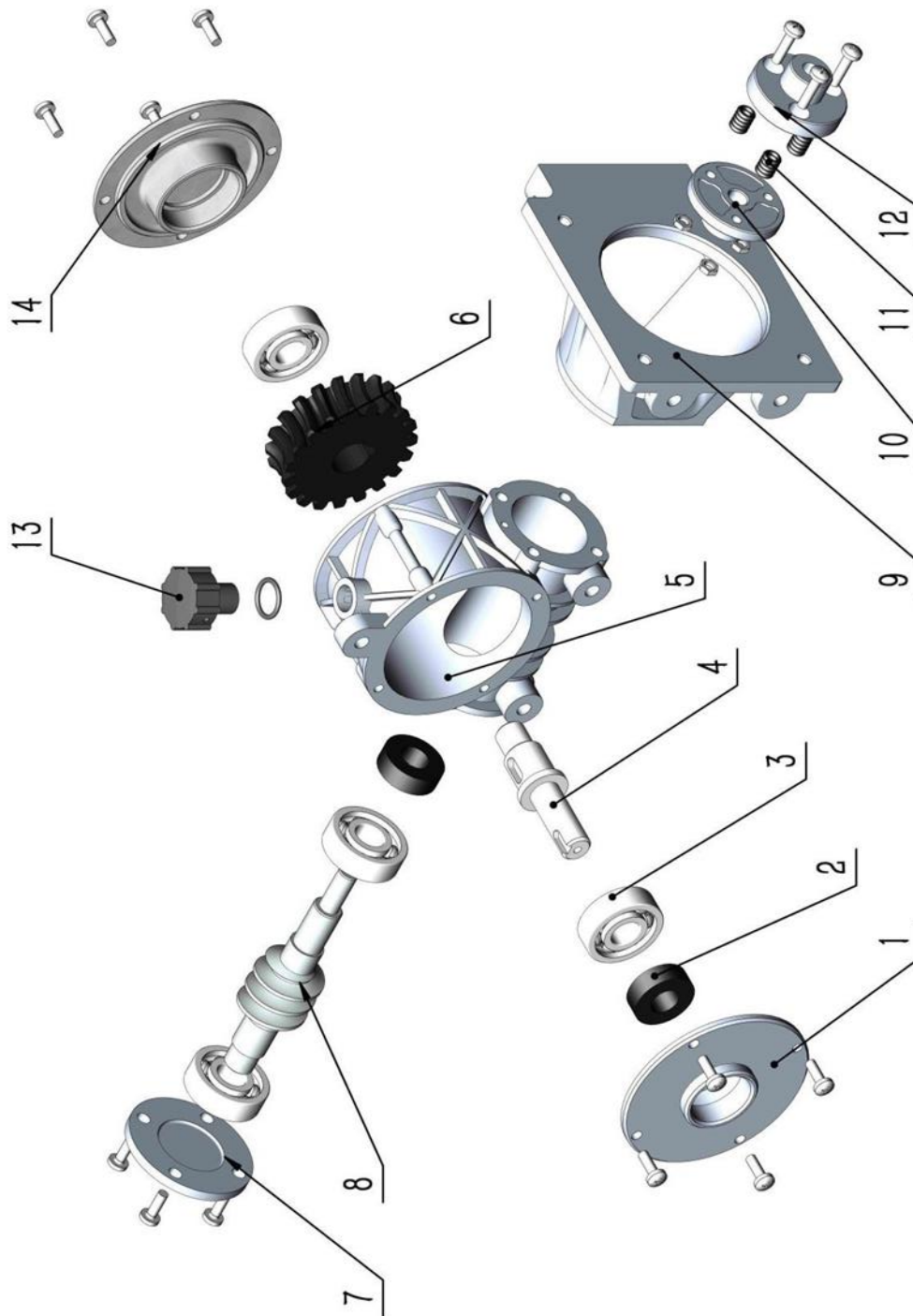

11.5 Worm gear box motor assembly

serial number	ERP	name	quantity	unit	Remark
5-1	11311050005	Worm gear box output gear cover	1	individual	
5-2	11311050004-35	Worm shaft output gear	1	individual	
5-3	11311050007.31	Worm gear box spacer	2	individual	
5-4	11311050007.42	Worm gear box spacer I	1	individual	
5-5	Attached picture	Worm Gear Box Assembly	1	individual	
5-6	9210200340818	Motor carbon brush	2	individual	
5-7	9220115000505	Vertical DC Motor	1	individual	

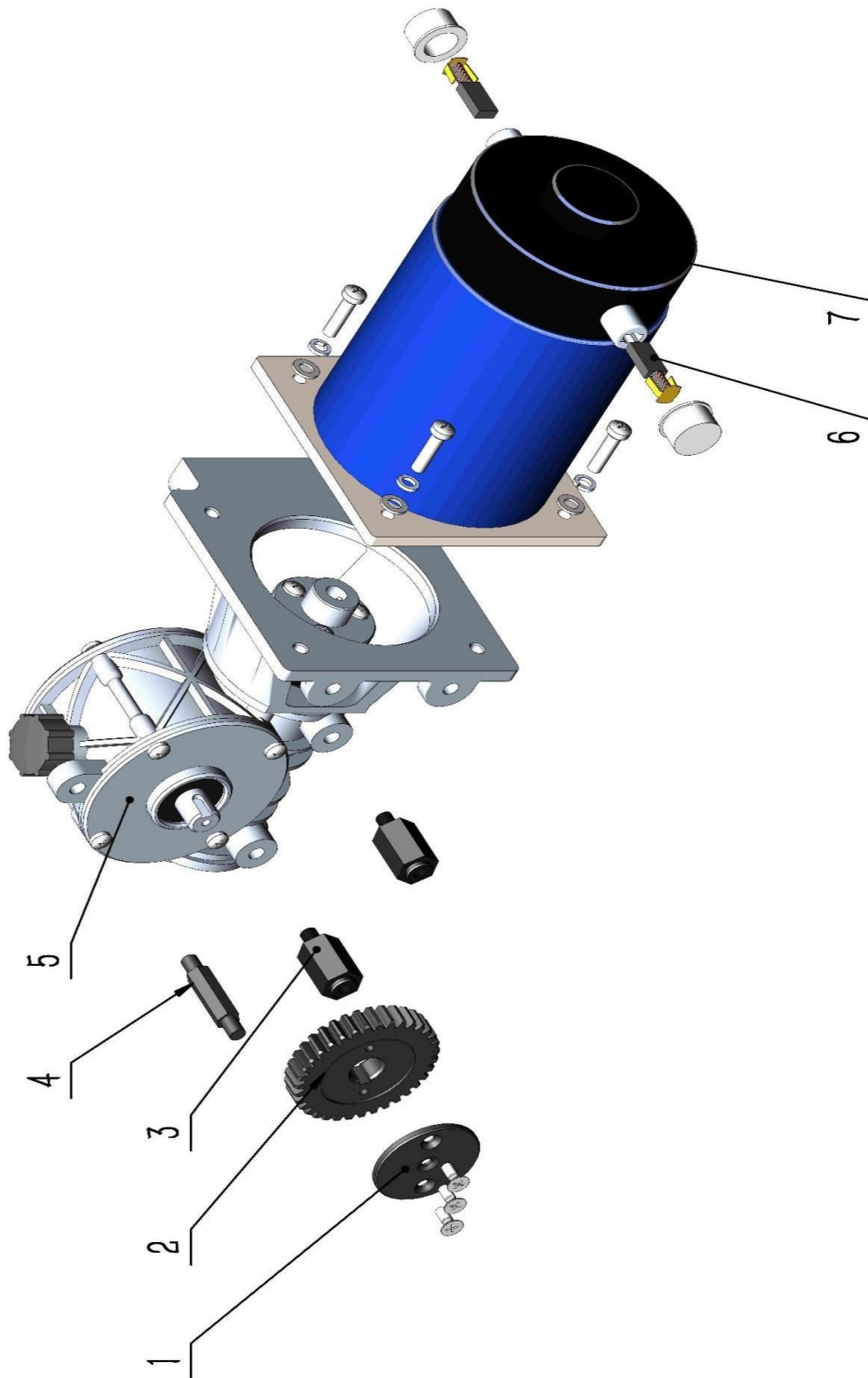

11.6 Conveyor Table Parts

Serial number	ERP	name	quantity	unit	Remark
6-1	9422112180136	conveyor	1	individual	
6-2	11111010009K	conveyor belt adjustment block	2	individual	
6-3	9715051105055	Equal length stud	2	individual	
6-4	9100401130520	Corrugated handle	2	individual	
6-5	9746036400012	shaft retaining ring	6	individual	Φ12mm _
6-6	9105200602011	Deep Groove Ball Bearings	2	individual	6201 Z
6-7	11111010102	rear roller bearing housing	2	individual	
6-8	11111010008	Conveyor rear axle	1	individual	
6-9	11111010101	rear roller	1	individual	
6-10	11111010001AS	work table	1	individual	
6-11	A111110906	Five-star handle assembly	4	individual	
6-12	9712011208165	Round head square neck bolts	2	individual	
6-13	11111010010S	Conveyor table support	2	individual	
6-14	11311010011S-HL	conveyor table	1	individual	
6-15	11111010004A	Spacer	2	individual	
6-16	11311010015	Axis backing plate	1	individual	
6-17	11111010002	Front roller shaft bearing housing	1	individual	
6-18	9105200601012	Deep Groove Ball Bearings	3	individual	6001-2Z
6-19	11311010012	Conveyor axis	1	individual	
6-20	11111010005	conveyor sprocket	2	individual	
6-21	7-21 _	A111110107 Three-eye bearing seat assembly	1	individual	
	7-18 _				
6-22	9104101106062	3 point chain	1	individual	
6-23	7-23	A111110105 Two-eye bearing seat assembly	2	individual	
	7-18 _				
	9746016400028 retaining ring for the hole (Φ 28mm)				
6-24	11111010003	front roller	1	individual	
6-25	11111010006-D2	Conveyor front axle	1	individual	

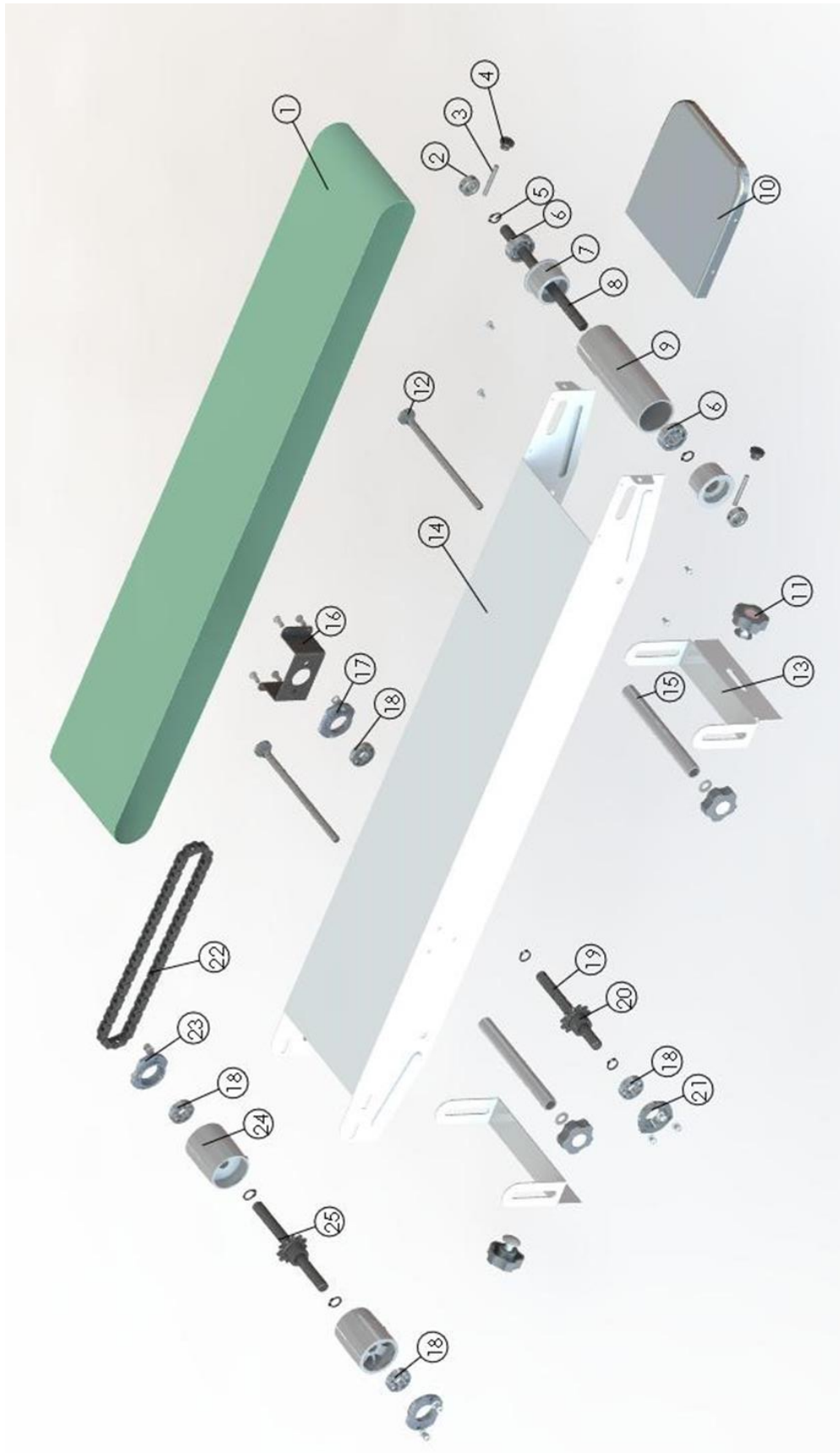

11.7 Chassis components

serial number	ERP	name	quantity	unit	Remark
7-1	11311040007S	rung	1	individual	
7-2	9400101000025T2	rubber feet	2	individual	
7-3	9450101111002	rubber feet	2	individual	
7-4	11111040006BS	foot (right)	1	individual	
7-5	9310101035125	switching power supply	1	individual	
7-6	9210110080042	Relay holder	1	individual	
7-7	9310121111030T	Speed control circuit board assembly	1	individual	
7-8	9100511030003	High breaking bracket	1	individual	
7-9	9212711602005	Miniature Circuit Breaker	1	individual	
7-10	9450101111006	handle seat	2	individual	
7-11	9201111031002	Pin-shaped socket	1	individual	
7-12	9300112522200	Carbon film potentiometer	1	individual	
7-13	9210200100011	knob	1	individual	
7-14	9241131410641T	Digital temperature controller	1	individual	
7-15	9212240140442	Springboard switch (square)	4	individual	
7-16	9212232025600	Emergency stop switch	1	individual	
7-17	9230210400006	inkjet printer touch screen	1	individual	
7-18	9160101112715	PVC panel paper	1	individual	
7-19	11271040100	chassis	1	individual	
7-20	9400101000025T	rubber feet	4	individual	
7-21	11111040006AS	foot (left)	1	individual	

