

CETM **CLEVELAND**
EQUIPMENT & MACHINERY COMPANY

CE-4800-HVE

Continuous Sealer
Operation Manual

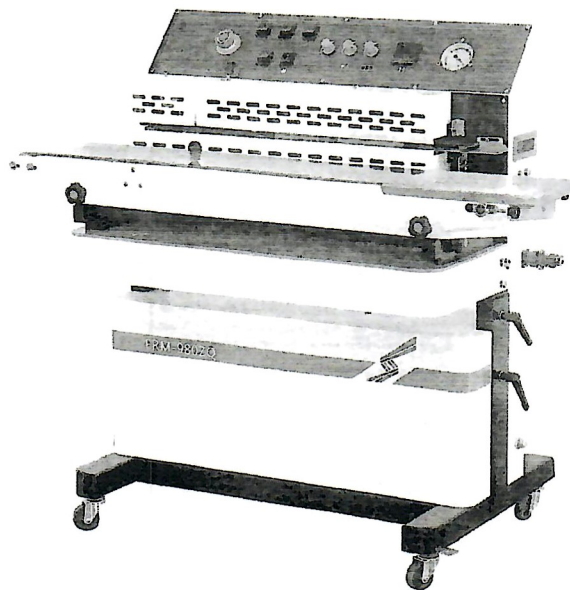

866-888-6327

sales@clevelandequipment.com

3889 E Raines Rd

Memphis, TN 38118

www.clevelandequipment.com

CONTENTS

Preface	1
1 Description of Product.....	2
1.1 Product application	2
1.2 Product features.....	2
1.3 Working principal	2
1.4 Product parameter	2
1.5 Product structure	3
2 Security, Preparation and Examination	3
2.1 Preparation before operating.....	3
2.2 Safety instruction	3
2.3 Environment condition	4
3 Installation.....	4
3.1 Essential condition for installation	4
3.2 Installation condition.....	4
4 Startup and Commissioning.....	5
4.1 Control panel	5
4.2 Power on	5
4.3 Starting power supply.....	6
4.4 Startup procedure	6
4.5 Stop operation	6
4.6 Emergency stop.....	6
4.7 Vacuum pump maintenance	6
4.8 Special oil for vacuum pump	9
4.9 Replacement and adjustment of the sealing belt	9
4.10 Forward-and-backward adjustment of conveyor table	10
4.11 Adjustment of sealing belt deviation	10
4.12 Conveying lifting adjustment.....	11
4.13 Adjustment for conveyor belt deviation	11
4.14 Pressure adjustment of embossing wheel.....	11
4.15 Printing mechanism adjustment method	12
5 Standard Operation and Parameter Setting.....	14
5.1 Preparation, adjustment and inspection before operation	14
5.2 Parameter setting.....	15
6 Product Maintenance.....	16
6.1 Maintenance announcements.....	16
6.2 Maintenance periodic table	16
7 Troubleshooting.....	17
7.1 Product fault analysis table.....	17
7.2 Motor maintenance.....	19
8 Equipment Handling and Storage.....	19
8.1 Equipped with carton packaging	19
8.2 Short-term storage	19
8.3 Long-term storage	19
8.4 Restart after long-term storage.....	19
9 Schematic Diagram.....	20
9.1 Electrical schematic diagram (see the attachment for details)	20

Preface

Thank you for buying the Continuous Band Sealer of CE-4800HVE!

This manual is for model CE-4800HVE.

This instruction manual has following content:

- Instruction on the product
- Precaution on safety
- Transportation and storage
- Installation
- Starting and operating
- Maintenance
- Troubleshooting
- Packing list

This manual gives a description of the installation and use of the product, and it includes following contents: the product's transportation, storage, installation, operation conditions, maintenance, troubleshooting and repairing.

Notice:

- Please read this manual carefully and understand it thoroughly before using..
- Make sure this manual is possessed by the operator or the managerial personnel of this product.
- Please retain this manual after reading and make sure it is available for reference if needed.
- Any questions, please contact the manufacturer or distributor.

Responsibilities:

- This manual is written carefully and for possible mistakes or the mistakes due to misunderstanding, the manufacturer does not take any responsibility.
- The manufacturer will not be responsible for the damage or problems caused by having not adopted the specified spare part.
- The manufacturer keeps the right of amendment on the parameter or parts without prior notice.
- All rights are reserved by manufacturer. And without written approval, printing of any part of this manual is forbidden. If found, the company reserves the right to pursue legal responsibilities.

Terms:

- Sealing belt(Teflon belt): to make the bag be out of touch of heating block to avoid influence the sealing effect.
- Heating block: consist of copper block and heating tube.

1 Description of Product

1.1 Product application

This sealer is suitable for sealing all kinds of plastic films, which is widely used in fields of food, medicine, chemicals, daily use and vegetable seeds etc. It is the best sealing equipment for packing batch products from factories and shops.

1.2 Product features

- This sealer, adopting electronic thermostat control unit and step less speed-adjusting transmission mechanism, easy to move with the wheels, suitable for sealing of small packaging bag.
- This machine is characterized by high efficiency in continuous sealing, reliable sealing quality, rational structure and convenient operation etc.
- The FRM series are all starting running from right side, it can also be customized as the request of clients, it can be customized as left side.
- After sealing, there will be stripe or netted pattern, it can also be optional with no pattern. According to requirements of clients, there are indentation printing wheel and counter for optional.
- Through adopting solid-ink roller printing mechanism, the machine can print desired colored label on bag while sealing, with the characteristics of high definition, instant print and instant dry, and strong adhesion. For types in R arrange, the machine can print two lines in font size two (18PT) and three lines in font size five (10.5PT), and 20 types can be arranged in each line. Special order for T arrange or multi-line types is available.
- This machine can seal various plastic film bags in different materials and can also be equipped with varied packaging production lines.

1.3 Working principal

After power supply being connected, electrothermal elements start to produce heat, which leads to rapid temperature rise of both upper and lower heating blocks. Required temperature and speed can be got through adjusting temperature controller and speed-adjusting mechanism. Open the plastic packing bag and make it smooth, hold the two sides of the bag mouth, let the air cock inside the bag slowly, the plastic packing bag will be transmitted by conveying belt, and its sealing part will be conveyed into the clearance between two sealing belts, then the sealing part will be clamped by two sealing belts and conveyed into the heating area. Sealing part is pressed by two heating blocks and pressing wheels there, which could make the plastic film fuse and stick together, after this, the sealing part will be conveyed into the cooling area for cooling, and then to be pressed by embossing wheel for making stripe or netted pattern, at last, colored label on the sealing part will be coded by printing wheel.

The transmission of sealing and printing is started by motor, which drives sealing belts, guiding belts and conveyor belt to work synchronously, as well as make printing mechanism work intermittently. It also intermittently drives the printing part working synchronously.

1.4 Product parameter

Parameter	Model
Item	CE-4800HVE Solid-Ink Coding Continuous Aerating and Air Suction Band Sealer
Voltage(V/Hz)	AC 220/50 110/60
Motor Power (W)	50
Vacuum Pump Power (W)	250
Sealing Power (W)	300×2
Printing Heating Power (W)	40×2
Speed (m/min)	0-12
Seal Width (mm)	10
Temperature Range (°C)	0-300(Adjustable)
Printing Type	Solid ink roller
Distance from Sealing Center to Conveyor (mm)	10-40
Distance from Base Plate to Interior Conveyor (mm)	68-85

Max. Distance from Sealing Center to Bag Opening (mm)	38
Conveyor Size (L×W) (mm)	1054×203
Overall Conveyor Load (kg)	≤10
Diameter of Charging Air Source Connecting Pipe	8
External Dimensions (L×W×H) (mm)	1054×550×900
Net Weight (kg)	67

1.5 Product structure

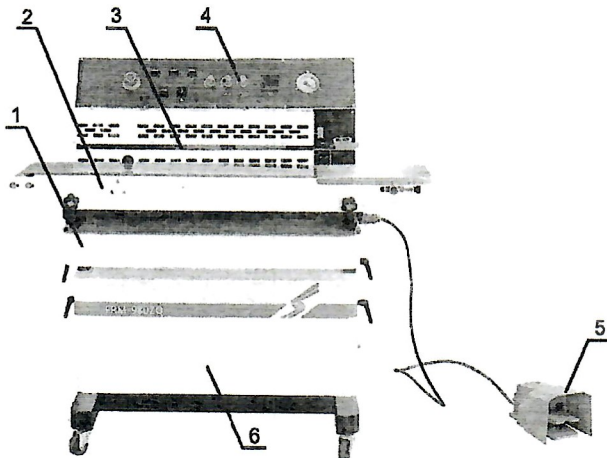

NO.	Name
1	Rack Assembly
2	Conveyor Assembly
3	Heating Elements
4	Control Panel Assembly
5	Foot Pedal
6	Vacuum Pump

2 Security, Preparation and Examination

2.1 Preparation before operating

This manual contains an elaborated description of carrying, storage, installation, activate, operation condition, maintain, troubleshooting of the product.

The installation of the machine is suggested to be operated by trained professionals.

Please be sure to follow the maintain instruction

- Please be sure to read the manual and fully understand it before operating the machine.
- If you have any problem with security, please contact the manufactory or your supplier.

2.2 Safety instruction

- Please confirm the voltage of this machine in order to avoid mistakes.
- This machine uses the single-phrase three wire system. The yellow-green double colored wire is the protective ground wire, it has to be get connected to ground separately and steady, it cannot be removed. The voltage wire should not be compressed, it ought to be rolled up and keep it in a cool and dry place.
- Forbidding to touch the electric assembly after the machine get connected with power.
- Forbidding to touch any transmission parts while operating the machine, in order to avoid getting wounded.
- Forbidding to open the security devices such as chassis and cover after activating the machine.
- Forbidding to touch the heating elements, solid-ink heating elements in order to avoid getting scald.
- In order to avoid to get scald, please let the machine sufficient cooling before maintaining.
- Forbidding to operate the machine under a wet or corrosive conditions.
- Please do not change components of machines at will.
- Please keep the inside and outside of machine clean, removing the burrs on the surface of sealing area in time.
- Ought to refuel and change oil the worm gear case on schedule, and add lubricant oil to the gears of gear wheel and chain wheel. (YP7408 semi-fluid gear oil)
- The power should be cut off when the machine is out of using. If the operator leaves the m then the machine must be power off.
- Please keep the manual in order to consult.

For Example:

	DANGER! Ignoring this safety precaution can result in serious or fatal injury accidents.
---	--

	WARNING! Ignoring this safety precaution can result in a serious injury.
---	--

	WATCH OUT! Ignoring this safety precaution can result in personal injury or property damage.
---	--

2.3 Environment condition

This product is suggested to be operating in a condition of normal temperature and indoor. If your operating condition is tough (such as an environment condition with corrosively air, temperature higher than 30°C or lower than 5°C, please contact the manufactory and your supplier.

3 Installation

Please read the manual carefully before installation. This manual provides a better understanding of installation, activating, maintain and operating of the machine. Manufactory will not be response for the machine failures caused by operation unfollowed the manual.

Manufactory hope client can have the machine to keep running with failures after purchasing it, if there are any problems, please contact the manufactory or the supplier.

3.1 Essential condition for installation

	CAREFUL! FAILURE MACHINE! If it is not fits the essential condition for installation, the machine will be damaged. Be careful and avoiding from injury! Please follow the essential condition for installation.
---	--

Please guarantee the installation condition fits the basic safety regulations.

3.2 Installation condition

- No inflammable and explosive gas.
- Environment temperature: 5-30°C. Please contact the manufactory or supplier, if the environment temperature is out of the range.
- Atmospheric Pressure: Standard atmosphere
- Ensure the voltage fits the requirement. (Pay attention to the nameplate on the machine)
- Ensure the machine is placed horizontally. It is the most significant element for machine running trouble-free)
- For a better heat dissipation, please keep at 10cm space around the machine to make it ventilated.
- Do not place the machine near the heat source or steam plant. (such as steamer or stove)
- Ensure that there is enough space for replacing component.

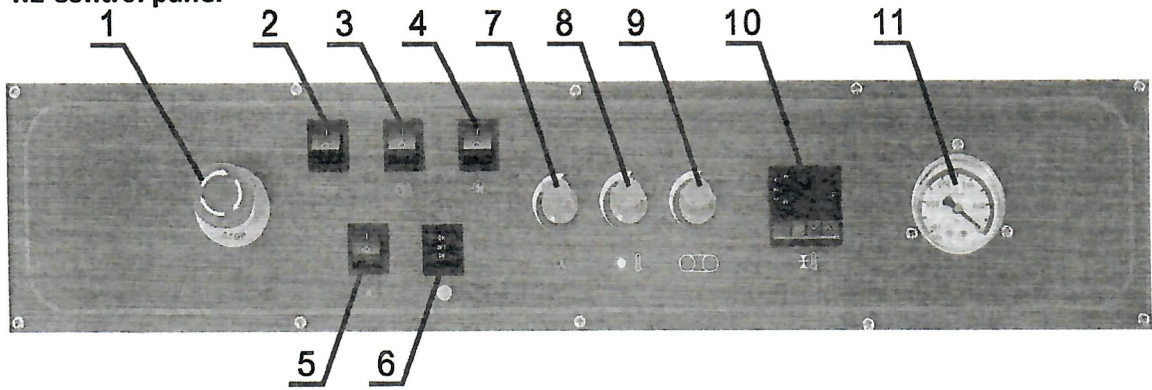

4 Startup and Commissioning

4.1 Control panel



No.	Name	Description
1	Emergency Stop	Used to stop the running of machine. Press it to stop the machine at any time. After pressing, the machine will stop all the operation.
2	Power	Used to turn on or off the machine power supply.
3	Seal	Optional opening and closing heat sealing function.
4	Fan	Open or close fan
5	Printer	Optional opening and closing solid-ink coding function.
6	Air Suction/ aeration	Optional Air Suction or aeration function.
7	Coding Position	Adjust the printing position on the bag film.
8	Solid -ink Temperature	Adjust the temperature of the heating block in the solid-ink.
9	Speed Knob	Adjust the belt speed.
10	Sealing Temperature	Adjust the temperature of the heating block.
11	Pressure gauge	Display pressure

4.2 Power on

DANGER! ELECTRIC SHOCK!

Please abide by safety operating regulations.

- Via rotating the Power Switch to start the machine.
- After the connection with the power supply, the indicator light will be on. And machine is now in the state of standby, ready to be operated.

4.3 Starting power supply



WARNING! ELECTRIC SHOCK!

Ensure that the socket used has protective grounding wires.

Be careful! Power mismatch will damage the machine!

Please check the power parameters of the machine by referring to the machine nameplate.

Please comply with safety guidelines and national accident prevention measures.

➤ Power/Ground

- Check whether the power supply voltage is consistent with the voltage in the machine's nameplate.
- Ensure the machine is properly connected to a grounded receptacle, so as to avoid the fire or electric shock (grounding line is the yellow green double color line).
- The cable must be free to move to avoid extrusion.
- Once the cable is damaged, please replace immediately.
- When there is machine malfunction or when the machine needs maintenance, please cut off power supply.
- If the machine will be idle for a period, please pack the cable.

4.4 Startup procedure

- Connect the power and press the emergency stop switch, the indicator lights up, adjust the heating speed knob, then the transmission parts run synchronously.
- Fine tune printing wheel knob, make the printing wheel rotating. Adjust it to the appropriate pressure and fix the limit screw.
- Turn on the heater switch, then the green light of temperature controller lights up. According to the material and thickness of the packing bag, adjust the temperature controller to the desired temperature. When the heating block begins to warm up, the machine shall be turned on at the same time.
- That whether it is necessary to turn on the fan for cooling depends on the material and thickness of packing bag.
- Optional opening and closing solid-ink coding function according to actual need.
- Adjust coding position to regulate the printing position on the bag film.
- Flatten and align sealing opening, then feed the bag by aligning the bag opening with the feed opening. When the bag opening is gripped by the sealing belts, which makes the bag moving forward automatically, at that moment, please do not push it in or pull it out by force, otherwise there will be irregular sealing or breakdown.
- If it is found that there is dirt attached to the sealing belt or the heating block, stop the sealer and clear it. Do not clear the dirt with hands when the temperature is high.

4.5 Stop operation

In order to prolong the service life of the sealer, before turning off the machine, please return the temperature-regulating knob to position 0 firstly, and turn on the fan. At the same time, the indicating temperature begins to fall and the sealing belt should still be in state of running. After several minutes later, when the temperature drops below 100°C, it is allowed to turn off the fan and main power switch.

4.6 Emergency stop

Press the Emergency stop, the machine will be stop working immediately. This switch is self-locking switch which will automatically lock after being pressed down. It needs to be clockwise rotated for 120 degrees to reset itself.

4.7 Vacuum pump maintenance

- The daily maintenance of the vacuum pump is essential to prolong the service time and ensure correct operation.
- It is suggested to exam all-round the vacuum pump at least once every year if the machine is used frequently. Any question or suggestions please contact the manufacturer or the supplier.

Filling and replacing oil



TAKE CARE! POLLUTION!

Please deal with the waste oil according to the environmental regulations.



TAKE CARE! SCALD!

The surface temperature of the vacuum pump will rise to more than 70°C when it is running. Don't touch the vacuum pump during its working. If it is necessary, please stop the machine, cool it down or wear thermal protective glove.

- Check the color of the vacuum pump oil.

The vacuum pump oil is bright and clear without any foam or muddle. If there are white materials after precipitation, it indicates there are foreign materials in the oil. Please replace the blackened vacuum pump oil or the oil with foreign materials.

- The service time of the vacuum pump oil

The service time of the vacuum pump oil depends on its working environment. To extract clean and dry gas, the vacuum pump oil should be replaced every 500 working hours or every six months.

- Please check oil level at least once a week. You can check through the oil window. If the oil level is too low, you need to fill oil.
- It is suggested to replace the vacuum pump oil mist filter at the same time when replacing vacuum pump oil.
- Keep the pump running for several minutes before replacing to get a proper temperature of the oil and the pump, so that the wet air and the impurities can be better absorbed and filtered. High temperature will volatilize the wet air in the pump so as to reduce the rust.

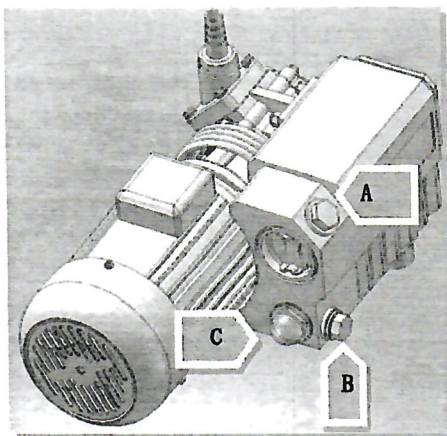

- A: Oil-filling hole
- B: Oil-drain hole
- C: Oil level indicator

Drain oil

- Open the back cover.
- Place a basin for oil under the oil-drain hole.
- Unscrew the oil-drain plug with wrench in correct size.
- Drain the oil.
- Put the oil-drain plug back after oil-drain.
- Dispose the waste oil as per environmental protection laws and regulations.

Note: When you unscrew the oil-drain plug, the oil will flow through the oil-drain hole, so there should be a basin for oil. At the end of the oil-drain, please lean the machine slightly so that the residual oil can be drained.

Filling oil



TAKE CARE! DAMAGE!

Correct oil type and quantity is essential to the vacuum pump. Improper vacuum pump oil or too much oil will damage the vacuum pump.

- The newly delivered machine should be filled with oil before use.
- Fill the oil after the oil-drain or when the oil level descends.
- Unscrew the oil-filling plug with wrench in correct size.
- Fill the machine with appropriate special oil for vacuum pump. Please refer to the Special Oil for Vacuum Pump section.
- Make sure the oil level is between 1/2 and 3/4 of the oil level indicator.
- Make sure the sealing ring is installed in the oil filler plug. Replace the ring when needed.
- Screw the oil filler plug.
- Wait for several minutes.
- Check whether the oil level is between 1/2 and 3/4 of the oil level indicator. If it is less than 1/2, please add more.
- If the oil level is between 1/2 and 3/4 of the oil level indicator, fix the back cover.
- Check weekly the oil level. If it is less than 1/2, please add more.

Replacing filter



TAKE CARE! POLLUTION!

The polluted filter should be disposed separately from other wastes according to the applicable regulation.

There are one or several filters in the vacuum pump, which is used to absorb and filter the oil mist. The filter will turn wet (saturated) and need replacement. The machine can't reach to the maximum vacuum if the filter is saturated.

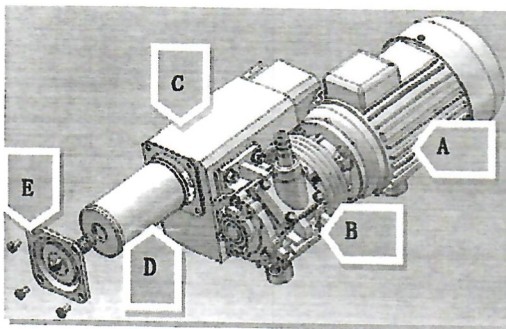

- A: Motor
- B: Pump body
- C: Oil tank
- D: Oil-mist filter
- E: Filter cover

- It is suggested to replace the filter at the same with the vacuum pump oil. The filter locates on the way of the vacuum exhaust pipe.
- The normal maintenance cycle of the oil-mist filter is between 6-12 months.

Replacing the oil-mist filter

- Open the back cover of the machine and find the oil-mist filter.
- Unscrew four bolts on the filter cover and take out the filter cover and the spring.
- Remove the old oil-mist filter and replace a new one.

- Reinstall the spring and the filter cover.
- Install the back cover to the housing.
- Dispose the wasted oil mist filter according to the environmental laws.

4.8 Special oil for vacuum pump

The temperature of the working environment is important for the choice of the oil type. The following table lists the relation among the working temperature, oil quantity and oil type.

There are two suggested brand for the oil: Shell Vitrea, Great Wall special oil for vacuum pump.

Vacuum pump oil	VM32	VM68	VM100
Viscosity level ISO-VG	32	68	100
Applicable temperature (°C)	<5	5-20	12-30
Dosage (L)	Please refer to the manual		

Note: If the oil applicable for low temperature is used under high temperature, the abrasion between the vacuum pump blade and the pump body will be aggravated and affect the service time of the vacuum pump.

Note: If the machine is not used under normal environmental temperature, please contact the manufacturer or the supplier.

4.9 Replacement and adjustment of the sealing belt

- Remove the safety cover, after the heating block cooling, rotate retaining washer by 90° on both upper heating block and upper cooling block to lift both two blocks, then loosen the springs on both embossing roller and pinch roller, remove the guiding belt, (as below figure).

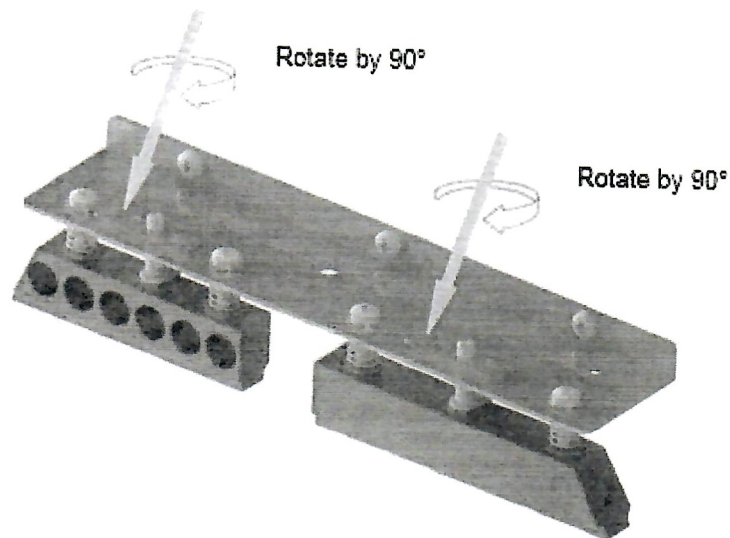

- Move the driven wheel seat (adjusting block) towards heating block, and remove the sealing belt.
- Replace it with a new sealing belt and install the guiding belt back.
- Adjust the driven wheel, heating blocks, cooling blocks, and pinch roller etc. to the original position.
- Connect the power supply to test the machine.
- Install the protection cover. When the temperature reaches the setting temperature, the machine is ready for work.

4.10 Forward-and-backward adjustment of conveyor table

Loosen the adjusting knobs on both sides first, and then move the conveyor table forward or backward in the long slot along the feet. Tighten the knobs on both sides after finishing the adjustment.

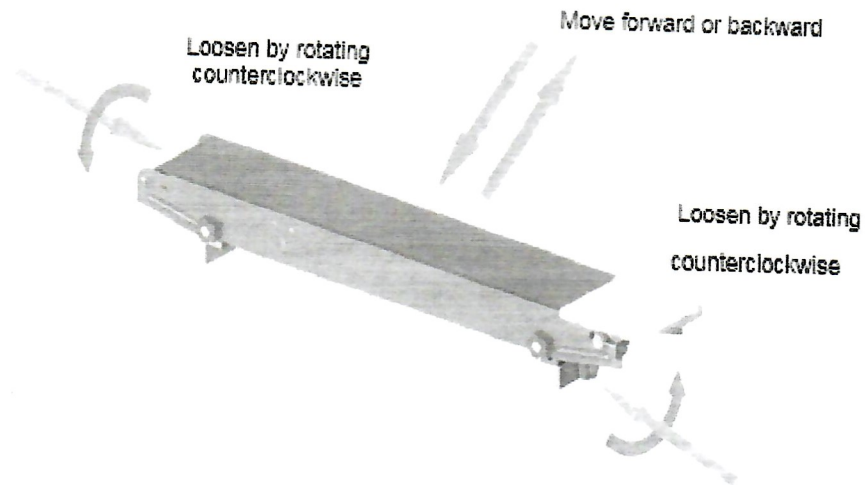

4.11 Adjustment of sealing belt deviation

If there is deviation of the sealing belt, it can be adjusted by adjusting the screw on the driven pulley seat (adjustment block) (as shown below).

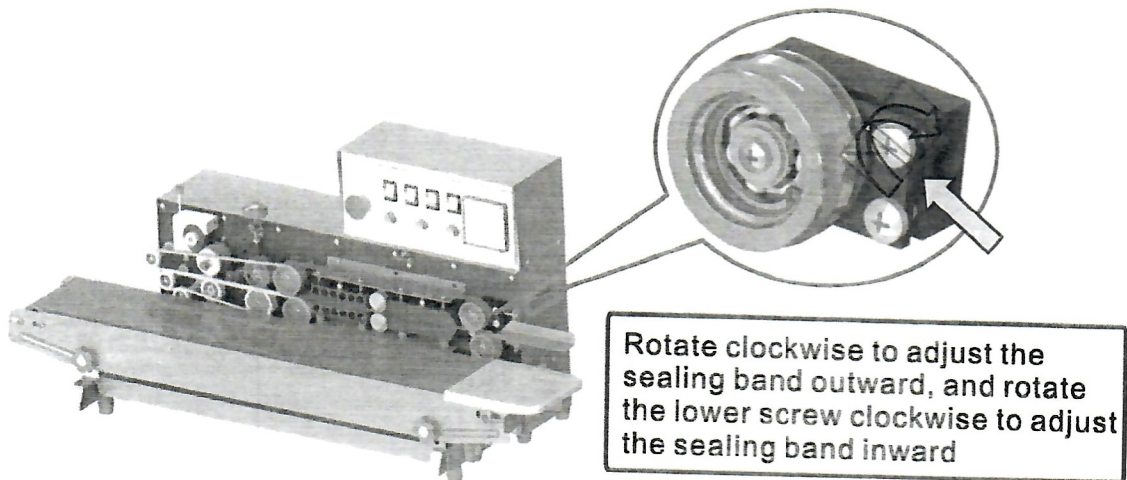

4.12 Conveying lifting adjustment

According to different materials, when the height of the conveying table needs to be adjusted, it can be adjusted by the adjusting knob in front of the conveying table (as shown in the figure below). After the adjustment, it needs to be tightened.

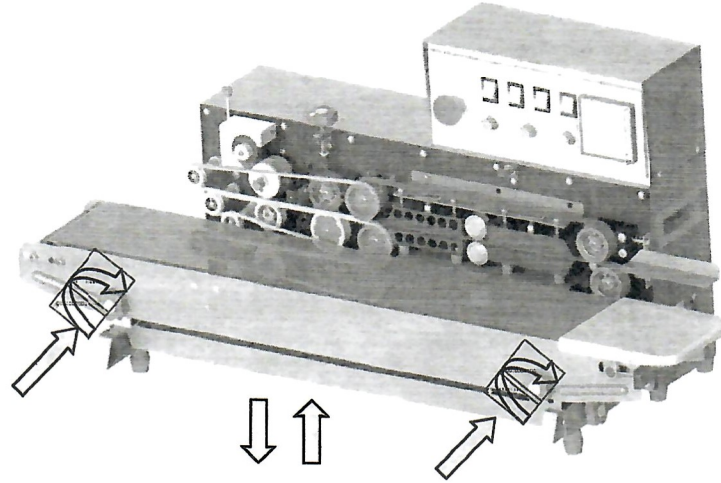

Rotate counterclockwise to loosen, which can make the conveyor table lift up and down as needed

4.13 Adjustment for conveyor belt deviation

If there is any deviation of the conveyor belt, it can be adjusted by the adjustment knob on the right conveyor table (as shown in the figure below). When adjusting the conveyor belt, keep the conveyor belt in tension, and never adjust it when the conveyor belt is slack.

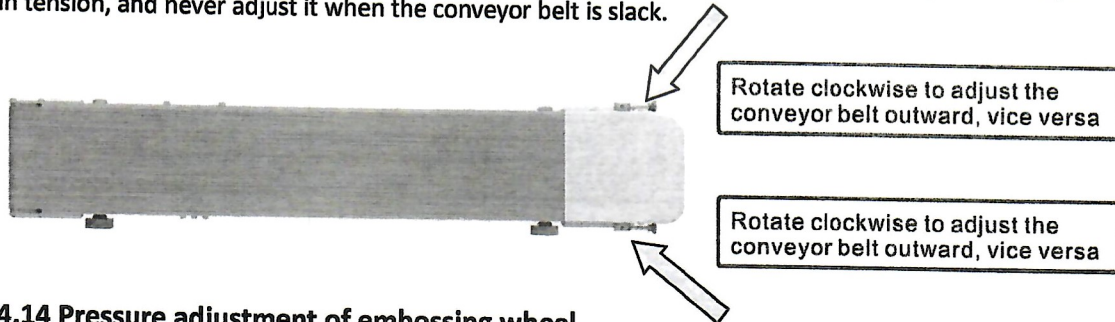

4.14 Pressure adjustment of embossing wheel

If it is necessary to deepen or lighten the texture of the embossing wheel, it can be adjusted by the adjustment knob above the embossing wheel (as shown below).

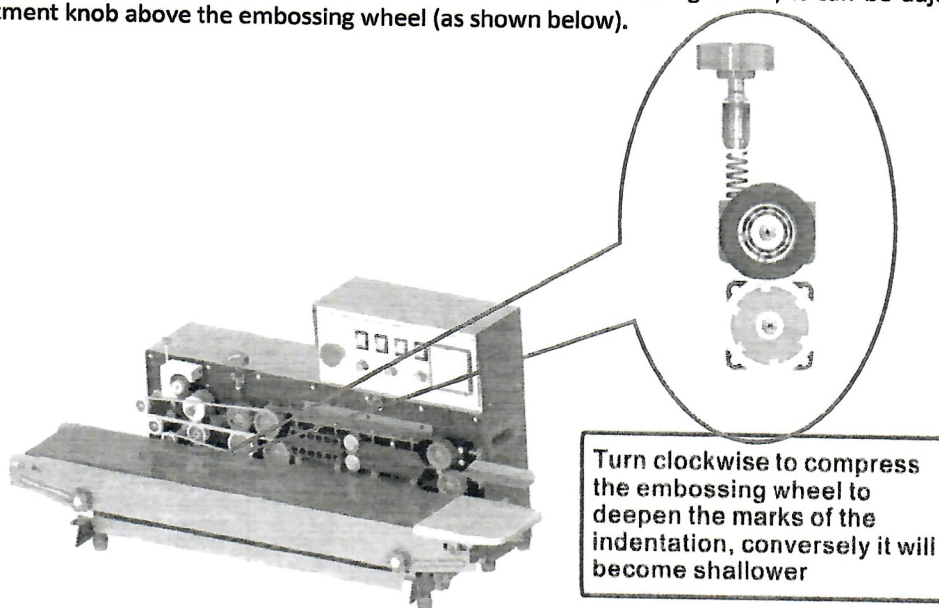

4.15 Printing mechanism adjustment method

- The choice of font arrangement: T-type and R-type font direction distinction (as shown below).

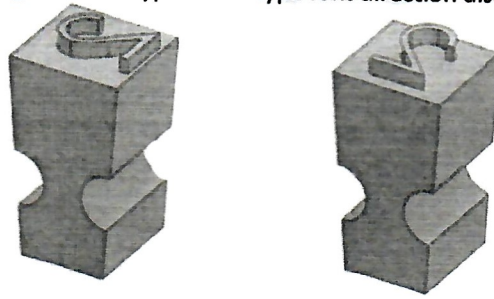

T Type character R Type character

- Reference arrangement of fonts on the printing wheel (as shown below)

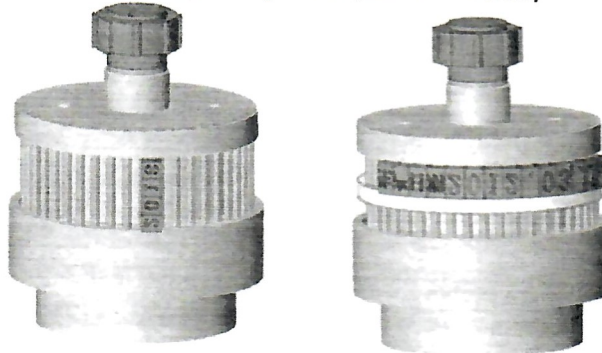

T type font reference arrangement

R type font reference arrangement

- Commonly used R-type arrangement printing effect

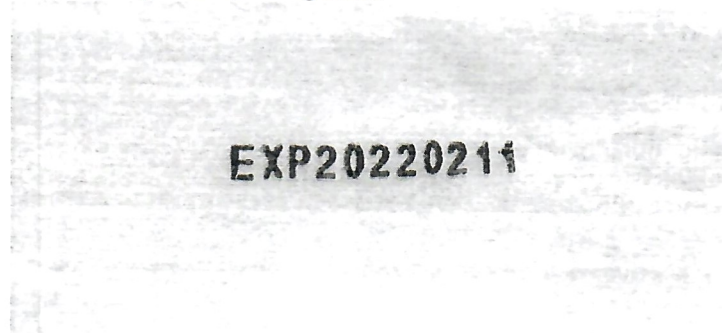

- Character replacement (as shown below)

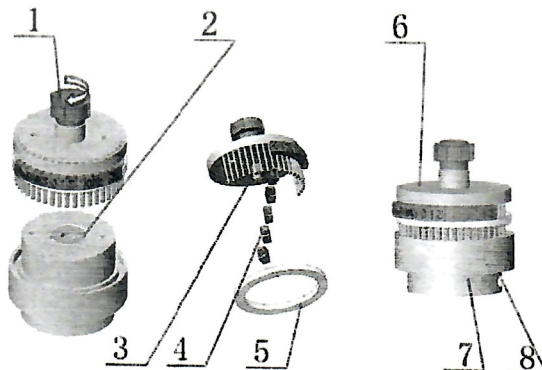

No.	Name
1	Red pin
2	End cap for printing wheel shaft
3	Cross pin
4	Font
5	Silicone rubber strip
6	Positioning pin
7	Printing wheel
8	Printing wheel set screw

- Rotate the red pin on the printing wheel cover by an angle to disengage the cross pin from the groove on the end cover of the printing wheel shaft, the printing wheel cover will automatically jump up, and the character can be changed after removing the cover.
 - After changing the character, press the silicon rubber strip, and then cover the printing wheel cover, insert the horizontal pin into the groove of the end cover of the printing wheel shaft, press the red pin to rotate and buckle it.
- **Adjustment of ink wheel and letter gap**
 - Turn the adjusting screw 5 clockwise, the ink wheel 1 will be tilted away from the printing wheel, conversely the ink wheel 1 will be pressed against the printing wheel under the action of the elastic element.
 - Adjust the adjusting screw 5 of the ink wheel swing lever, and rotate the printing wheel, so that the surface of the font and the ink wheel 1 are slightly in contact. Rotating the printing wheel by hand can easily move the ink wheel will be good (as shown below).

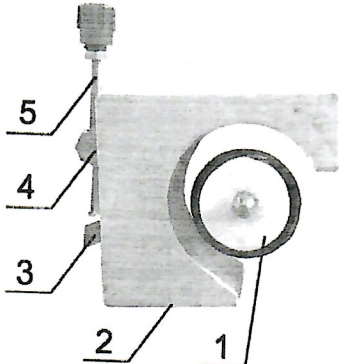

No.	Name
1	Ink wheel
2	Ink wheel heating block
3	Pendulum
4	Adjustment column
5	Adjusting screw

- **Pressure adjustment of printing wheel and silicone wheel**

There is no contact between the characters on the printing wheel and the silicone wheel when not working, and they are contacted only when printing. Loosen the screw 4 at the front end of the silicone wheel, and rotate the hexagon of the eccentric sleeve 3, so that the surface of the character in rotation rotates slightly with the silicone wheel 2. If printing thicker packaging bags, you need to adjust them properly, and the pressure should not be too large. After adjusting, tighten the screws (as shown below).

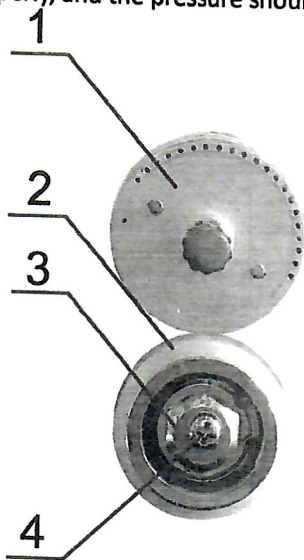

No.	Name
1	Printing wheel
2	Silicone wheel
3	Eccentric wheel
4	Screws

- **Temperature adjustment of printing wheel and ink wheel**

All adjustment knobs are in the 0 position when the machine leaves the factory. The user needs to adjust it by himself. The temperature can be lowered properly when the ink wheel is used for the first time. After a period of time, the temperature can be increased appropriately, so that the deep ink will leak out to extend the life of the ink wheel. When the ink wheel reaches the working temperature, lightly touch the outer surface of the ink wheel with white paper. It is advisable to be stained with a little ink. The

temperature should not be too high or low.

The specifications of the ink wheels suitable for this machine are shown in the following table. There are white, yellow, red, blue, green, brown, black and other colors to choose from. In the packaging bags that need to be cooked after printing, the medium-temperature or high-temperature series ink wheels should be used, and the temperature should be adjusted accordingly when using.

Variety	Outer diameter (mm)	Height (mm)
Low temperature series 120-150°C (Code 935)	Φ36	16
	Φ36	32
	Φ36	40
Medium temperature series 135-165°C (Code 932)	Φ36	16
	Φ36	32
	Φ36	40
High temperature series 150-175°C (Code 930)	Φ36	16
	Φ36	32
	Φ36	40

● **Printing position adjustment**

The user can adjust the label position knob to set the position of the printed label according to the length of the bag mouth.

● **Adjustment for the number of printed label lines**



Arrange the fonts within the set range, and then use the supplied silicone strips to fix the fonts in the desired axial position.

5 Standard Operation and Parameter Setting





BE CAREFUL! INJURED!

Please refer to this manual to operate the machine. Do not remove the necessary protective cover or casing.

BE CAREFUL! PINCH!

When the machine is running, it is forbidden to reach into the transmission wheel with both hands to avoid pinching hands!

BE CAREFUL! SCALD!

The surface temperature of the heating block of the machine can reach above 200°C during heat sealing.
Even after cooling, the performance is still high temperature.

- If you have questions about the operation and function of the machine or the manual does not provide relevant information, please contact the manufacturer or supplier.
- If the machine is not in normal working or is accompanied by abnormal noise during operation, immediately press the emergency stop switch, then turn off the power of the whole machine, contact the manufacturer or supplier, stop the machine and cut off the power.
- In case of failure, please contact the manufacturer or supplier.

5.1 Preparation, adjustment and inspection before operation

The machine is equipped with a grounding three-pin socket, and the power supply should be well

grounded to ensure safe production.

- For the first time use or when the interval between use is too long, the electric heating element will get wet. It should be preheated at low temperature for several minutes before normal operation.
- Adjust the height of the conveyor table and its front and rear positions according to the external dimensions of the packaging bag.
- Adjust the position of the seat (feeder) according to the external dimensions of the sealing line to the bag mouth.
- Adjust the gap between the upper and lower heating blocks and the upper and lower cooling blocks according to the material and thickness of the seal, adjust the pressing force of the non-return blade to control the gap between the two sealing belts, and increase clockwise (increasing the gap), Counterclockwise is down (narrowing the gap). The gap between the two sealing tapes is about the thickness of one layer of packaging bag, which should ensure the sealing is strong and the embossing is clear, and the distance between the two ends of the sealing is not too long.

5.2 Parameter setting



BE CAREFUL! DAMAGE THE MACHINE!

Unreasonable parameter setting may damage the machine or shorten the service life of the machine.

- Unreasonable parameter setting may damage the machine or shorten the service life of the machine.
- Unreasonable parameter setting may not complete all procedures or seal properly.
- If you have questions about the operation and function of the machine, please contact the manufacturer or supplier.

➤ Speed parameter setting

The control panel has a speed knob to adjust the sealing speed. Clockwise rotation increases the sealing speed, and counterclockwise rotation decreases the sealing speed.



➤ Best parameters

- The sealing center of the bag to the edge of the bag is 10-20mm.
- The quality of bag sealing is determined by the three elements of heat sealing temperature, sealing speed and pressure.
- The setting temperature should be adjusted slowly according to the thickness of the bag from low to high.
- The setting speed should be adjusted from slow to fast according to the sealing effect.
- The sealing pressure is set to the appropriate pressure at the factory and is suitable for most product bags. If your product bag adjusts the temperature and speed and the desired sealing effect is still not achieved, the pressure roller can be adjusted, and the pressure changes from small to large. Adjustment can achieve the desired sealing effect.

➤ Common material heat sealing temperature reference table

Material name	Thickness/um	Recommended temperature setting °C	Heat sealing speed m/min
LDPE	30~160	105~150	6~10
MDPE	40~120	115~120	7.2~10.2
HDPE	40~90	125~150	7.2~10.2
PP	40~60	135~160	7.2~10.2

6 Product Maintenance

BE CAREFUL! RISK OF ELECTRIC SHOCK!

The power supply must be completely disconnected before performing maintenance on the machine.

In order to prolong the service life of the product, prevent malfunctions, and achieve the best packaging effect, daily maintenance of the machine is necessary. If the machine is used more frequently (more than 4 hours per day), it is recommended to perform professional maintenance every three months, and if it does not exceed 4 hours per day, complete maintenance every six months (depending on the location, environment and product)

However, some users can perform simple maintenance work on the products according to their needs. The maintenance work is as follows.

6.1 Maintenance announcements

- Before maintenance, the power of the machine must be completely disconnected, and the power plug should be removed from the wall socket.
- If the machine does not operate normally or makes abnormal noise, please turn off the power immediately and contact the manufacturer or supplier.
- Do not perform high-pressure cleaning on the machine. High pressure cleaning will seriously damage the electronic devices and other parts of the machine.
- Do not let water enter the control panel of the machine, otherwise it will cause damage to the circuit.
- If the user fails to maintain the machine according to the instructions in this manual, resulting in machine failure or damage, the manufacturer will not be liable.

6.2 Maintenance periodic table

Maintenance phase	Maintenance content
Daily maintenance items	<ol style="list-style-type: none"> 1. Use a brush to remove attachments from the sealing belt and guiding belt caused by operation. 2. Clean the conveyor table with a damp cloth. 3. Whether there is noise or abnormal noise during the operation of the motor.
Monthly maintenance items	<ol style="list-style-type: none"> 1. Check whether the sealing belt is damaged. 2. Check the guiding belt for damage. 3. Motor carbon brush cleaning. 4. Cleaning the filter sponge of the air pump
Half-year maintenance items	<ol style="list-style-type: none"> 1. Check the motor carbon brush wear, it is recommended to replace the motor carbon brush once a year. 2. Lubricate the exposed gear mesh with grease.
Annual maintenance items	<ol style="list-style-type: none"> 1. Carry out general inspection according to the above items 2. Check the rubber wheel for aging. If the aging is serious, the rubber wheel needs to be replaced. 3. Check the temperature rise time of the temperature controller. If the temperature rises to more than ten minutes, consider replacing. 4. Check whether electrical components such as switches, emergency stops, potentiometers, fans, etc. are operating normally. 5. Check and add grease to the gears, shafts, universal joints and couplings of the transmission part, and replace severely damaged parts if necessary. 6. Clean the worm gear box and replace the lubricant (Great Wall brand 000# extreme pressure lithium grease lubricant).

7 Troubleshooting

7.1 Product fault analysis table

Problem	Reason	Solution
Fail to work	<ol style="list-style-type: none"> 1. Power supply disconnected 2. Fuse broken or Circuit breaker tripped 3. Emergency Switch fail to reset after being Pressed 	<ol style="list-style-type: none"> 1. Check the power socket 2. Replace fuse or circuit breaker 3. Reset the Emergency Switch
Sealing belt is off-tracking.	Driving wheel shaft is not parallel to driven wheel shaft.	Adjust two adjusting screws on driven wheel seat.
Sealing belt is easy to broke.	<ol style="list-style-type: none"> 1. Too much tension on sealing belt. 2. Sealing belt is off tracking. 3. Crease on sealing belt. 4. Adhesive film or other dirt attached to sealing belt surface. 5. Sealing belt is easy to burn. 	<ol style="list-style-type: none"> 1. Adjust the vertical adjusting screw on driven wheel seat, so as to make sealing belt less loose. 2. (see the point above) . 3. No crease on sealing belt. 4. Clean its surface in time. 5. Clearance between two heating blocks is too small or temperature is too high.
Embossing is not clear	<ol style="list-style-type: none"> 1. Embossing wheel is worn out. 2. Pressing spring on embossing wheel is not tightened to enough degree. 	<ol style="list-style-type: none"> 1. Replace embossing wheel 2. Adjust the embossing wheel's tightening spring
There is resistance when the sealing belt is conveying.	The clearance between heating blocks or cooling blocks is too small, the friction is too much.	Adjust the clearance between sealing belts properly, which should be about thickness of packing bag in one layer, so that not only ensure the strong sealing and clear printing, but not make the two ends of sealing part extend too long.
There is block or fold phenomenon when the packing bag is conveyed to pressing wheel or embossing wheel.	Too much pressure caused by pressing wheel or embossing wheel.	<ol style="list-style-type: none"> 1. Adjust the pressing wheel or embossing wheel to proper pressure, so as to make the clearance between two sealing belts be about thickness of packing bag in one layer. So that not only ensure the strong sealing and clear printing, but not make the two ends of sealing part extend too long. 2. Adjust limiting screw after adjusting clearance.
Conveyor belt is off-tracking.	The driving roller shaft is not parallel to driven roller shaft.	Adjust two adjusting screws of driven roller shaft (rear shaft) on conveyor.
Conveyor belt and sealing belt don't move synchronously.	Too small tension on conveyor belt.	<ol style="list-style-type: none"> 1. Tighten the chain of driving roller shaft(front shaft) and middle shaft properly. 2. Tighten the conveyor belt properly.
Ink roller printing mechanism doesn't work.	<ol style="list-style-type: none"> 1. The power supply is not connected. 2. Main control PC board is not inserted in place or poor contact. 3. Main control PC board is damaged. 	<ol style="list-style-type: none"> 1. Check whether the power line is connected and indicating light is on. 2. Check whether plug for PC board is inserted in place or wire end falls off. 3. Check and replace PC board.
Printing wheel doesn't work.	<ol style="list-style-type: none"> 1. Start sensor's touching head is blocked. 2. Start sensor is not clean, whose hole is blocked by dust. 	<ol style="list-style-type: none"> 1. Clean the obstacle. 2. Clean the dust on sensor's surface. 3. Check and replace PC board. 4. Repair round pin.

	<p>3. Main control PC board has been damaged</p> <p>4. Round pin on clutch falls off or is damaged.</p> <p>5. Electromagnetic clutch's wire is broken.</p>	<p>5. Repair clutch.</p>
<p>Printing wheel doesn't stop.</p>	<p>1. Sensor (groove sensor) is damaged, moved, or its surface covered by dust.</p> <p>2. Main control PC board is damaged.</p>	<p>1. Replace or correct position of sensor or clean its surface.</p> <p>2. Check PC board and replace it.</p>
<p>No heat for ink roller heating block or printing.</p>	<p>1. Heating pipe or wire is damaged</p> <p>2. Heating PC board is damaged</p> <p>3. The potentiometer on knob is damaged</p> <p>4. Carbon brush seat is not in place.</p> <p>5. Carbon brush is damaged</p>	<p>1. Replace heating pipe.</p> <p>2. Replace PC board.</p> <p>3. Replace potentiometer.</p> <p>4. Adjust and tighten nut then.</p> <p>5. Replace.</p>
<p>The temperature of heating block for ink roller printing mechanism is out of control.</p>	<p>The relay for temperature control PC board is damaged.</p>	<p>Check and replace temperature control PC board.</p>
<p>The printing position is out of control.</p>	<p>1. Tightening screw on printing wheel is loose.</p> <p>2. Main control PC board is damaged.</p>	<p>1. Tighten the screw.</p> <p>2. Check and replace PC board.</p>
<p>The noise in the gear box increases</p>	<p>The lubricating oil of worm gear box needs to be changed</p>	<p>Use Great Wall 000# super pressure lithium grease</p>
<p>Starting current or the working is too high.</p>	<p>Overflowing pump oil or incorrect oil type.</p>	<p>Check the oil level and type.</p>
	<p>Excessive viscosity when in low temperature.</p>	<p>Replace the proper pump oil.</p>
	<p>Exhaust filter blockage.</p>	<p>Clean or replace the filter.</p>
<p>The pump overheats during working.</p>	<p>Overflowing/insufficient oil.</p>	<p>Exam and adjust the oil level</p>
	<p>Poor heat dissipating</p>	<p>Clean the blade of the radiating pump and the motor to improve the ventilation.</p>
<p>Strange noise during working</p> <p>Driving components wears out or loose.</p>	<p>Strange noise during working</p>	<p>Strange noise during working</p>
	<p>Driving components wears out or loose.</p>	<p>Driving components wears out or loose.</p>
<p>Vent smoking or exhausting oil drip</p> <p>Overflowing pump oil</p> <p>Let the excessive oil out. Exhaust filter installed in the inaccurate position or the material breaks. Reinstall or replace the exhaust filter. Exhaust filter blockage. Clean or replace the filter.</p>	<p>Vent smoking or exhausting oil drip</p>	<p>Vent smoking or exhausting oil drip</p>
	<p>Overflowing pump oil Let the excessive oil out. Exhaust filter installed in the inaccurate position or the material breaks. Reinstall or replace the exhaust filter. Exhaust filter blockage. Clean or replace the filter.</p>	<p>Overflowing pump oil Let the excessive oil out. Exhaust filter installed in the inaccurate position or the material breaks. Reinstall or replace the exhaust filter. Exhaust filter blockage. Clean or replace the filter.</p>
	<p>Vent smoking or exhausting oil drip</p>	<p>Vent smoking or exhausting oil drip</p>

Vent smoking or exhausting oil drip		
Oil leak of vacuum pump	The small granule is adhered in the pump impeller blades	Run the pump in the opposite direction for 10 seconds, oil drainage, refuel, repetitive operation until normal or contact with the supplier

7.2 Motor maintenance

1. Stop machine when any abnormal occurs to motor, continue to use till problem solved.
2. Dedust and clean motor at regular intervals. Alcohol, gasoline and liquid with benzene chemicals should be avoid using, otherwise affecting paint of motor cover
Carbon brush is designed to be used 2500 hours continuously and commutator 2500 hours. Motor internal and commutator external should be cleaned every 120 hours after use. (Use alcohol to clean commutator).
3. Replace carbon brush and commutator immediately after they worn out.
4. Avoid damages like friction, rain, and chemical corrosion...etc. Use motor under normal environment. Contact suppliers if use motor under bad condition such as corrosion, temperature above 30°C or under 5°C...

8 Equipment Handling and Storage

8.1 Equipped with carton packaging

- The product is wrapped and fastened with filler in the carton.

Note: When the machine is palletizing on a pallet, the maximum should not exceed 5 layers.

- Make sure that the wrapping film is wrapped on the machine reliably.
- Please move according to the direction of the arrow of the carton. Do not carry it upside down.
- When palletizing products on a pallet, use a forklift to move the machine.

Note: The machine is equipped with a conveying table. Hold the handle when moving the machine. Do not carry the machine by supporting the conveying table.

8.2 Short-term storage

- Turn off the power switch, unplug the power, and put away the power cord.
- Remove dust.
- If possible, put a plastic bag to prevent dust.
- Store in a dry, dust-free and shockproof room.

8.3 Long-term storage

When the machine leaves the factory, anti-corrosion treatment has been done inside, no need to use protective oil for treatment. If the storage conditions are bad (such as corrosive atmospheric environment, high temperature or frequent temperature changes), it can be treated with protective oil. If you have any questions, please contact the manufacturer or supplier.

- Turn off the power switch, unplug the power, and put away the power cord.
- Remove dust.
- Put on plastic bags to prevent dust.
- If possible, keep the original packaging.
- Store in a dry, dust-free and shockproof room.

8.4 Restart after long-term storage

Follow the instructions in the "Installation" and "Startup" sections of this manual.

9 Schematic Diagram

9.1 Electrical schematic diagram (see the attachment for details)

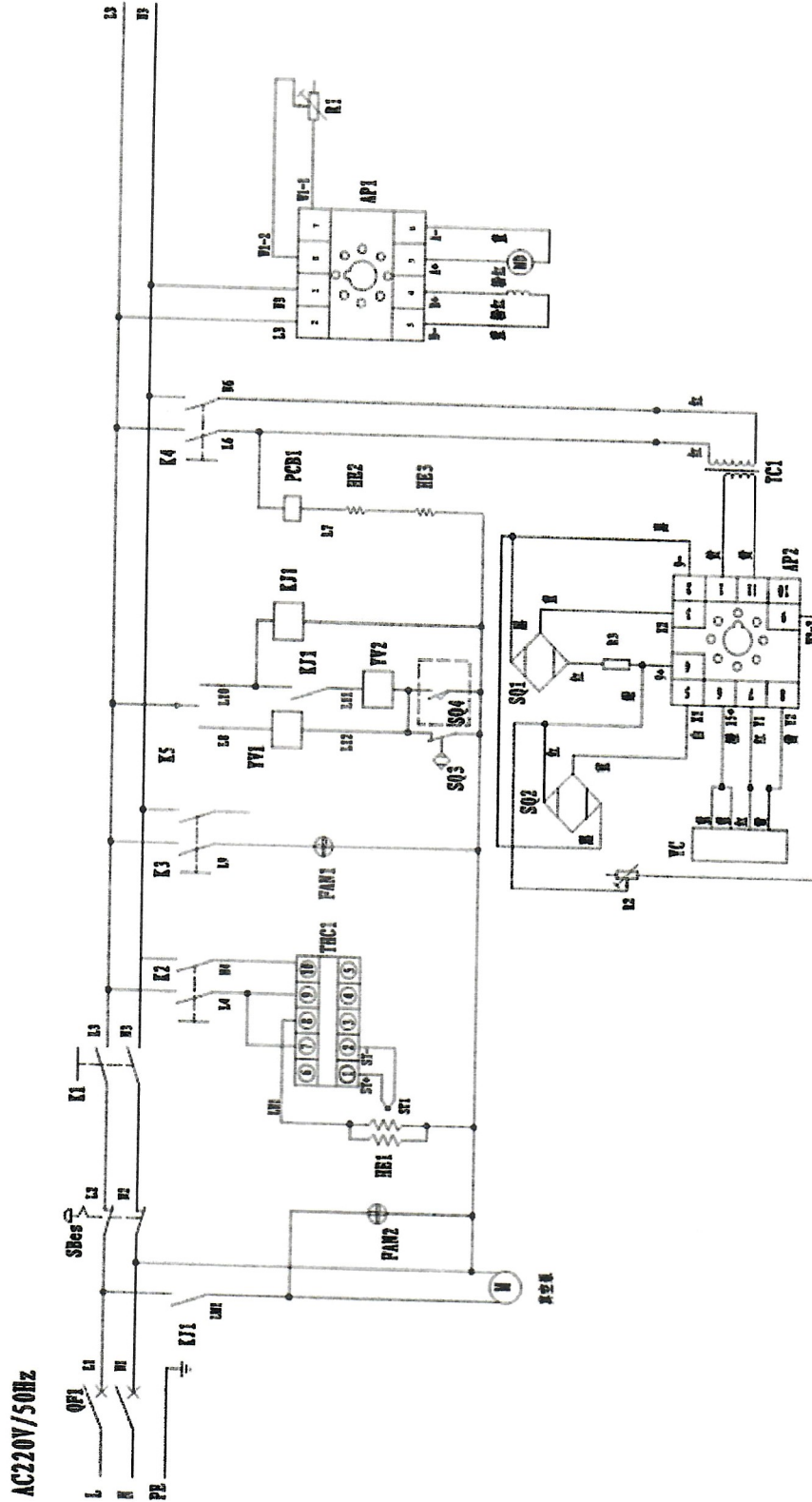

- QF1-Circuit breaker
- SBes-Emergency stop switch
- K1-Power switch
- K2-Sealing switch
- K3-Fan switch
- K4-Printing switch
- K5-Gas filling (exhausting) switch
- R1-Speed regulating potentiometer
- R2-Printing position adjustment potentiometer
- HE1-Sealing heating tube
- HE2-Solid ink roller heating tube
- HE3-Solid ink roller heating tube
- MD-Speed adjusting motor
- FAN1-Fan motor
- FAN2-Fan motor
- TC1-Transformer
- YC-Electromagnetic clutch assembly
- SQ1-Groove type optical coupling
- SQ2-Printing photoelectric sensor
- SQ3-Proximity switch
- SQ4-Pedal switch
- THC1-Heating temperature controller
- ST1-Thermocouple
- AP1-Speed adjusting board
- AP2-Main control board
- PCB1-temperature adjusting board
- YV1-Gas filling solenoid valve
- YV2-vacuuming solenoid valve
- KJ1-Gas filling/exhausting switch relay
- M-Vacuum pump

