



Cleveland Equipment

FG-1000

Tabletop Gear Pump Liquid Filler

USER MANUAL



866-888-6327

sales@clevelandequipment.com

4403 Delp Street • Memphis, TN 38118

www.clevelandequipment.com



Contents

1 SAFETY INSTRUCTION	3
2 PRODUCT DESCRIPTION	4
2.1 COMPONENTS.....	4
2.2 CONTROL PANEL	5
2.2.1 Test Mode	5
2.2.2 Manual Mode.....	6
2.2.3 Auto Mode	7
2.2.4.1 Setting Page (Manual mode)	8
2.2.4.2 Setting Page (Auto mode).....	9
2.2.5 Memory Page.....	10
2.2.6 Recipe List Page.....	11
3 BEFORE OPERATION.....	12
3.1 CONNECTIONS.....	12
3.2 DRIVEN PUMP AND DISPENSING AIR.....	13
4 OPERATION	14
4.1 OPERATION STEPS.....	14
5. After operation	16
5.1 Cleaning.....	16
5.2 Nozzle assembling.....	21
5.3 MAINTENANCE.....	25
6 TROUBLESHOOTING.....	26
7 CONTACT INFORMATION.....	27



1 SAFETY INSTRUCTION

This manual is designed for operators who are not acquainted with the machine, so please follow the instructions to operate and adjust the machine step by step. If you cannot thoroughly understand some of the instructions, please ask experienced technicians for help or contact us. Thank you!

Note: Please read this user manual in detail before taking any action to operate the machine!



- This machine is driven by 110 or 220 VAC. The voltage should fit for the power standard of the machine and should always stay within the security limit.



- Only engineering technicians are allowed to make adjustment of the machine, but any adjustment is forbidden while the machine is running. Failure to follow this warning may expose the operator to danger.



- Do not place the machine near high temperature or inflammables. The places where are not stable or where the machine will be crashed easily are also not suitable to place the machine.

- To prevent from getting electric shocks, the machine cannot be placed in a humid environment.

- Do not attempt to remove/replace parts or to use the machine for any other purpose other than what is recommended by us.

- Do not randomly apply lubricants to any part of the machine.

Notice of Equipment Improvements & Document Revisions

We continually devote to developing and researching for new items and reserves the right to change or terminate the production specifications and features which are presented in this manual without notice and without taking any responsibilities. We have also strived to provide all the needed information in this guide, but if there is any error, we reserve the right to correct for the next revisions.



2 PRODUCT DESCRIPTION

2.1 COMPONENTS

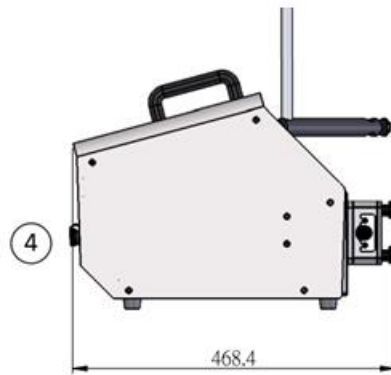
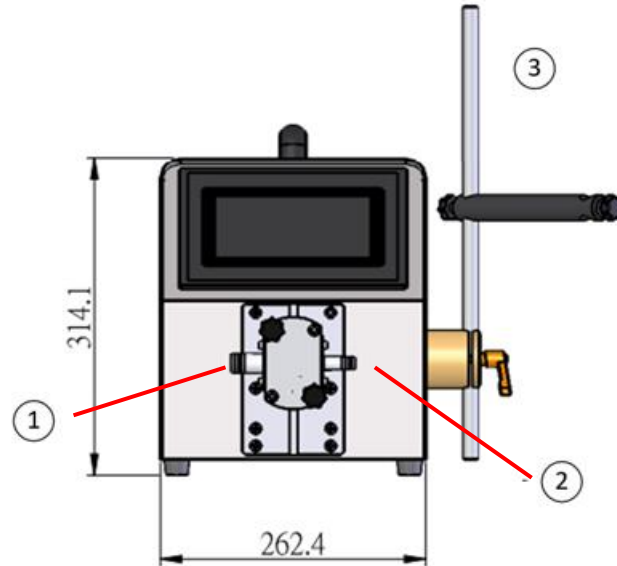

① Inlet Hose

③ Bracket

② Outlet Hose

④ Power Switch / Socket



2.2 CONTROL PANEL

2.2.1 Test Mode

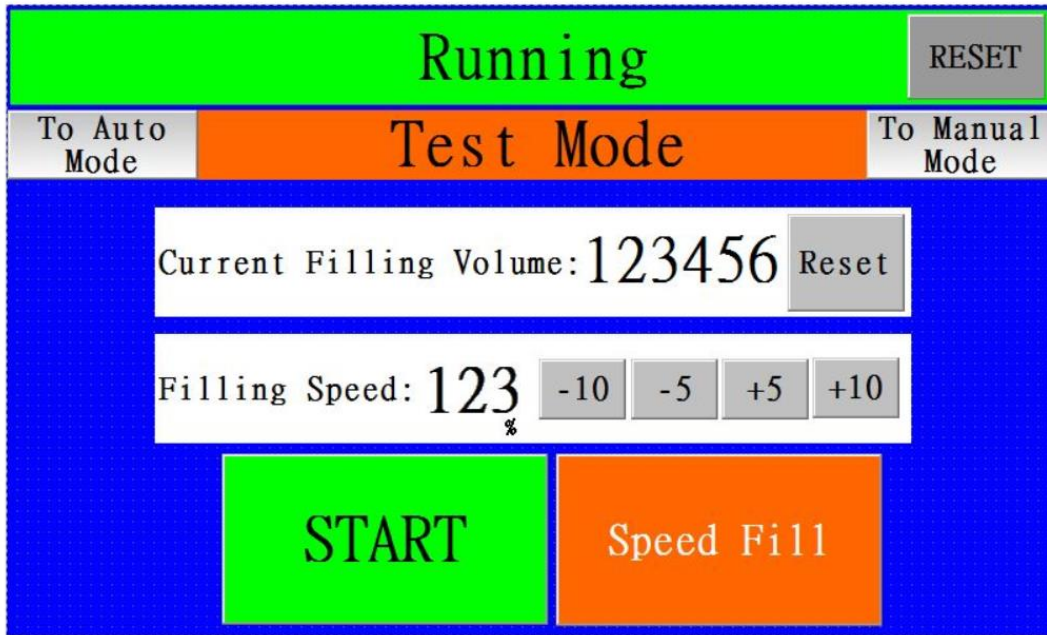

Reset	Reset the machine condition.
To Auto Mode	Enter auto mode.
To Manual Mode	Enter manual mode.
Current Filling Volume	The test result of filling volume.
Filling Speed	To set up the filling speed in test mode.
Start	Press start to test the filling volume.
Speed Fill	To fill in high speed to exclude the air in outlet tube.



2.2.2 Manual Mode

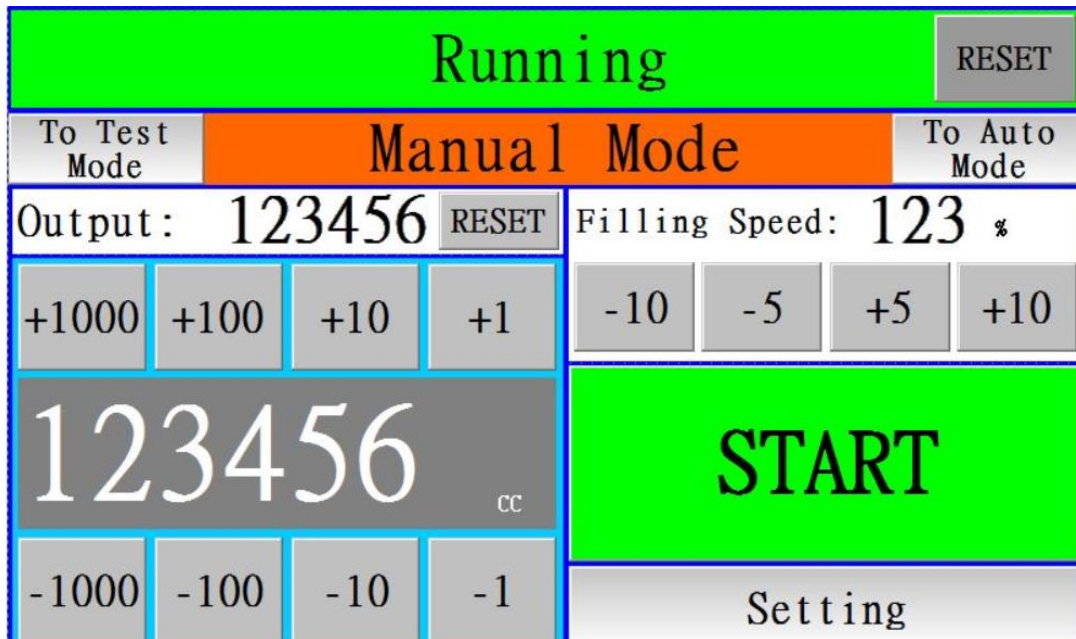

Reset	Reset the machine condition.
To Test Mode	Enter test mode.
To Auto Mode	Enter auto mode.
Filling Speed	To set up the filling speed in manual mode.
Output	The number of filled bottles. (Press RESET for one second, it will re-zero)
Start	Press start button to fill.
Setting	Enter setting page.
Filling Volume	Press the number button to adjust the volume or press CC to key in directly.



2.2.3 Auto Mode

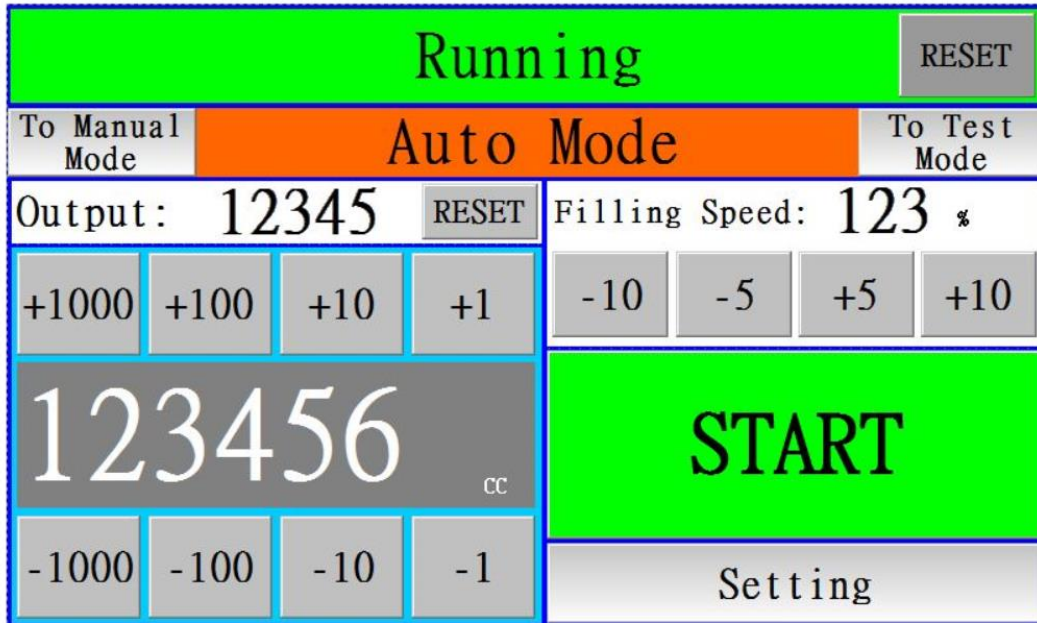

Reset	Reset the machine condition.
To Manual Mode	Enter manual mode.
To Test Mode	Enter test mode.
Filling Speed	To set up the filling speed in auto mode.
Output	The number of filled bottles. (Press RESET for one second, it will re-zero)
Start	Press start button to fill.
Setting	Enter setting page.
Filling Volume	Press the number button to adjust the volume or press CC to key in directly.



2.2.4.1 Setting Page (Manual mode)

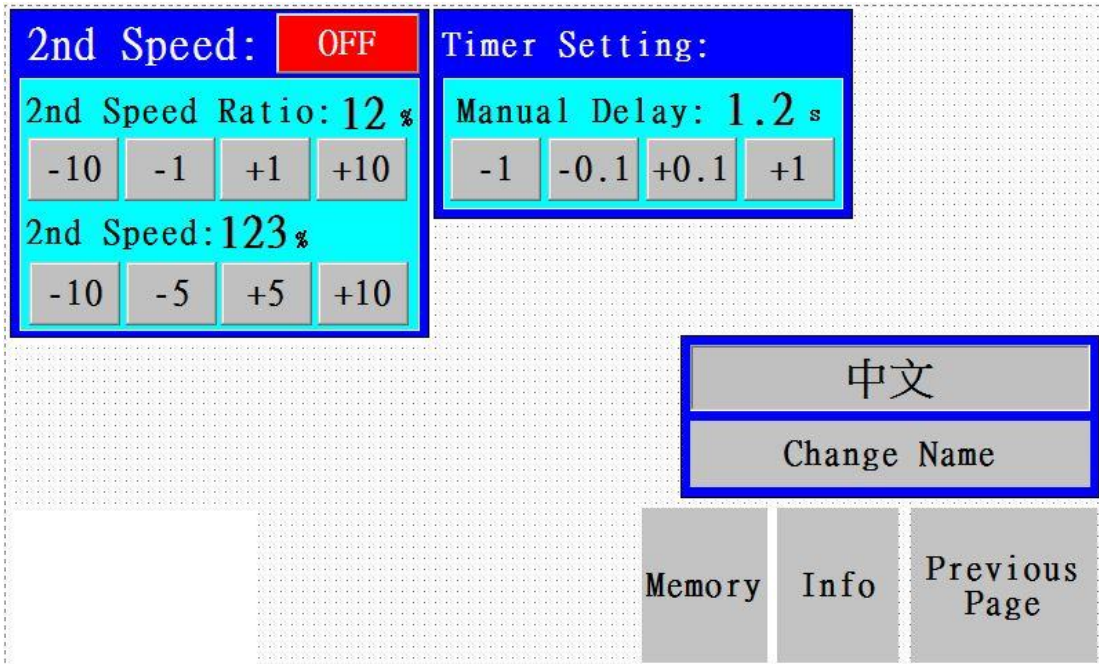

OFF	Turn on/off the function of 2 nd speed.
2 nd Speed Ratio	Select the filling percent to start 2 nd speed.
2 nd Speed	To set up the filling speed of 2 nd Speed.
Timer Setting	To set up the waiting time before filling 1 bottle in manual mode.
Memory	Enter memory page.
Info	Enter info page.
Previous Page	Back to previous page.
Change Name	To set up or change the recipe name



2.2.4.2 Setting Page (Auto mode)

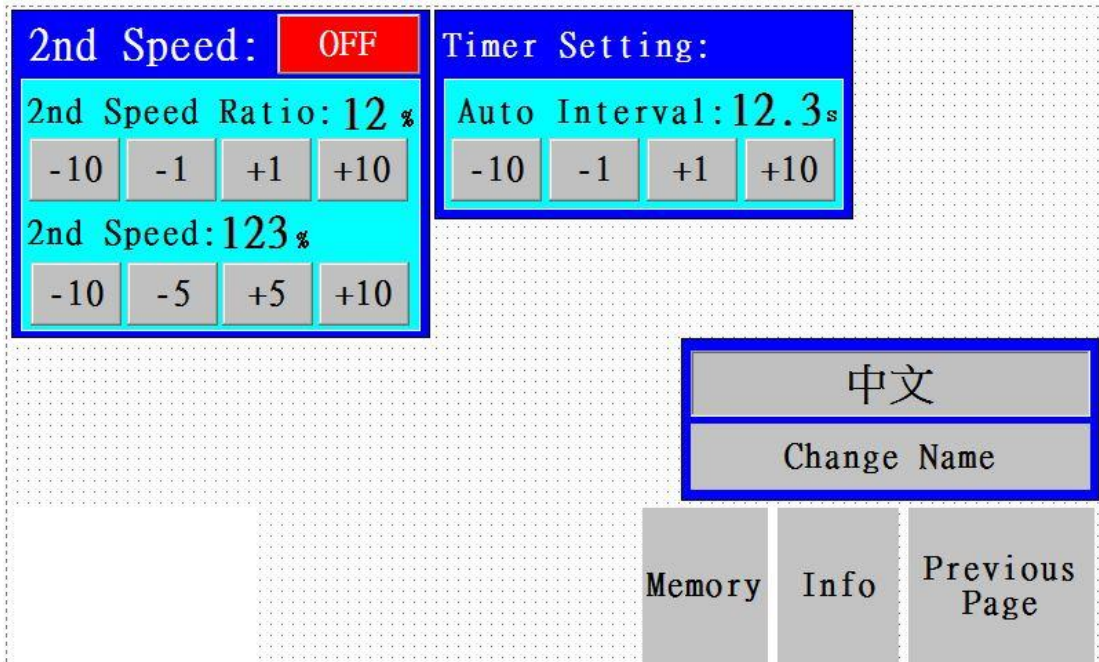

OFF

2nd Speed Ratio

2nd Speed

Timer Setting

Memory

Info

Previous Page

Change Name

Turn on/off the function of 2nd speed.

Select the filling percent to start 2nd speed.

To set up the filling speed of 2nd Speed.

To set up the waiting time before filling 1 bottle in auto mode.

Enter memory page.

Enter info page.

Back to previous page.

To set up or change the recipe name



2.2.5 Memory Page

Recipe Code	12		Present Value	Recipe
Product Name			中文	中文
Manual Filling Delay			1.2	1.2
Auto Filling Interval			12.3	12.3
Current Filling Volume			123456	123456
Filling Speed-Test			1234	1234
Filling Speed-Manual/Auto			1234	1234
Reverse Filling Speed-Manual/Auto			1234	1234
Reverse PULSE Value			12	12
Diving Time			1.2	1.2

Previous Page	Recipe +1	Recipe -1	Test Manual Auto		
	SAVE	LOAD			

- | | |
|---------------------|---|
| Product Name | Please name your recipe in this column. |
| Current | The present value in setting page. |
| RECIPE | The parameter value of selected recipe. |
| Pervious Page | Enter recipe list page. |
| Recipe+1 / Recipe-1 | To select saved recipe. |
| SAVE | To save Present Value as recipe. |
| READ | To load RECIPE value. |
| Test | Enter test mode page. |
| Manual | Enter manual mode page. |
| Auto | Enter auto mode page. |



2.2.6 Recipe List Page

Recipe List 1/2

Recipe1		Select	Recipe6		Select
Recipe2		Select	Recipe7		Select
Recipe3		Select	Recipe8		Select
Recipe4		Select	Recipe9		Select
Recipe5		Select	Recipe10		Select

Next Page Test Manual Auto

Recipe List 2/2

Recipe11		Select	Recipe16		Select
Recipe12		Select	Recipe17		Select
Recipe13		Select	Recipe18		Select
Recipe14		Select	Recipe19		Select
Recipe15		Select	Recipe20		Select

Previous Page Test Manual Auto

- | | |
|-----------------|--|
| Select | To select the recipe as filling parameter. |
| Next Page | To next page of recipe list. |
| (Previous Page) | (To previous page of recipe list.) |
| Test | Enter test mode page. |
| Manual | Enter manual mode page. |
| Auto | Enter auto mode page. |



3 BEFORE OPERATION

3.1 CONNECTIONS

Step1 Connect the tube wit the inlet hose and outlet hose.

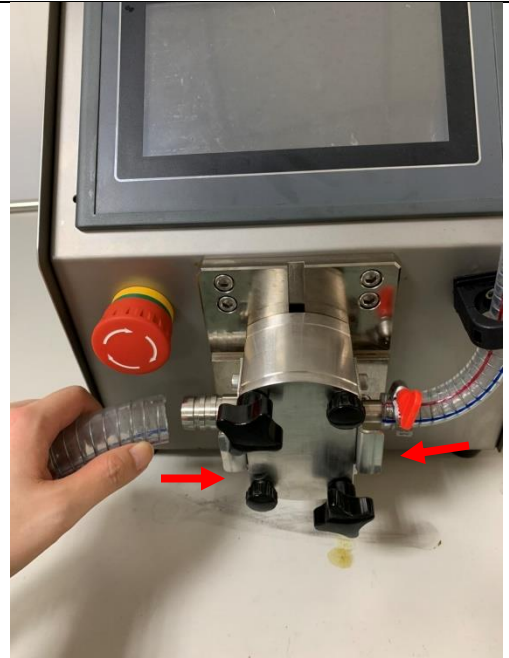

Step2 Tighten the hose clip.





3.2 DRIVEN PUMP AND DISPENSING AIR

- 3.2.1 Switch the filling mode to the Test Mode.
- 3.2.2 Adjust the filling speed over than 400RPM.
- 3.2.3 Aim the opening of the nozzle to the tank or other container and **push** the start button **continuously**. When the pump starts operating, the liquid will be sucked and filled into the filling tubes.
- 3.2.4 Please **push** the start button **continuously** until there is no more air in the filling hose.

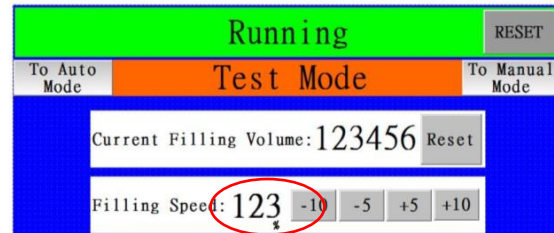

3.2.5 Fix the filling nozzle onto the bracket, and then the preliminary operation is done.

TIP 01: While testing, please adjust to HIGH filling speed to help the air to eliminate from the filling hoses. (This action can prevent from influencing the filling process afterward.)

TIP 02: The liquid in the hoses has to flow out smoothly without air so that it will not affect the filling accuracy.

TIP 03: The best way to fill is to let the surface of the filling liquid in the tank higher than the pump.





4 OPERATION

4.1 OPERATION STEPS

4.1.1
Switch on the power.



4.1.2
Turn the emergency stop button clockwise to activate the function.



4.1.3
Place the bottle (or container), which you want to fill, under the filling nozzle and adjust the machine with proper filling speed. (The larger the scale is, the faster the filling speed will be. However, too fast or too slow will both affect the filling accuracy.)

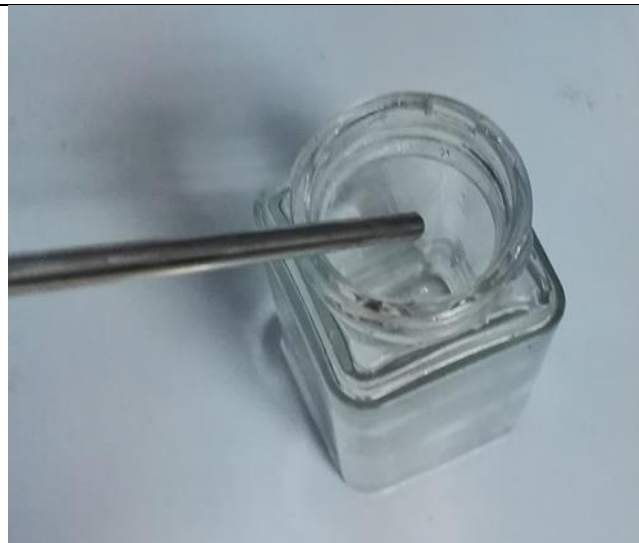



<p>4.1.4 Switch the to Test Mode, push the start button continuously until the required filling volume, and then note down the parameter shown on the screen. ★ Please push continuously, or the parameter will not be accurate for the filling volume.</p>	
<p>4.1.5 Switch to <u>Manual Mode</u>, and get into the parameter setting to enter the parameter you noted down from the previous step.</p>	
<p>4.1.6 Press start button to fill. If the volume still has some discrepancy, please adjust the volume on manual mode directly.</p>	
<p>4.1.7 While filling, the screen will show the output of the bottles being filled to assist the operator to measure the production.</p>	



5. After operation

5.1 Cleaning

5.1.1 Disassemble the filling hoses.



5.1.2 Disassemble the screws





5.1.3 Take off the pump and push the fixing plate to take off the inlet hose and outlet hose

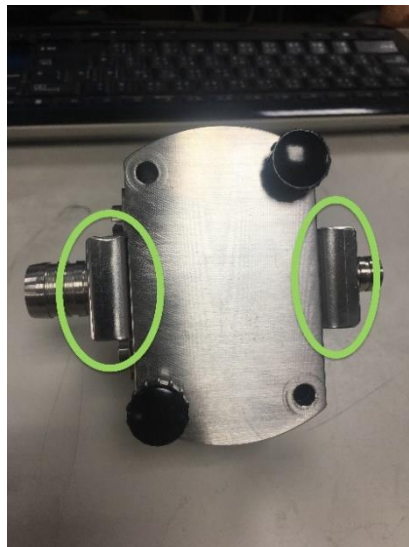

5.1.4 Disassemble the screws





5.1.5 Take off the back plate



5.1.6 Take off the main body of the gear pump

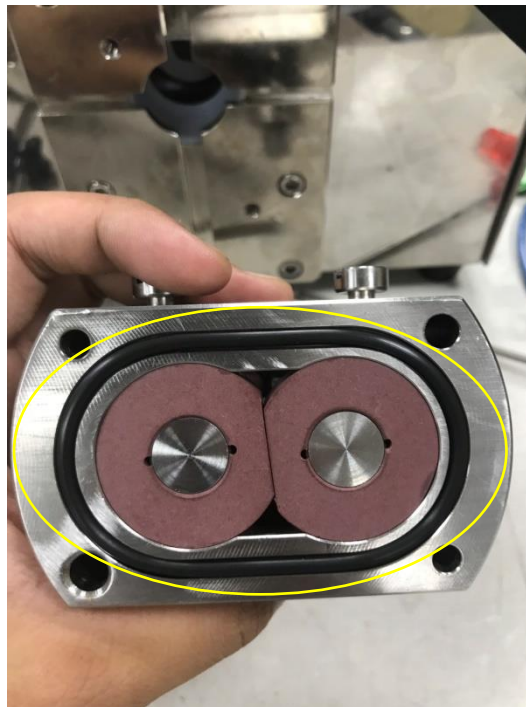



5.1.7 Clean the components of the gear pump



5.1.8 Assemble the main body of gear pump



5.1.9 Assemble the shaft seal set

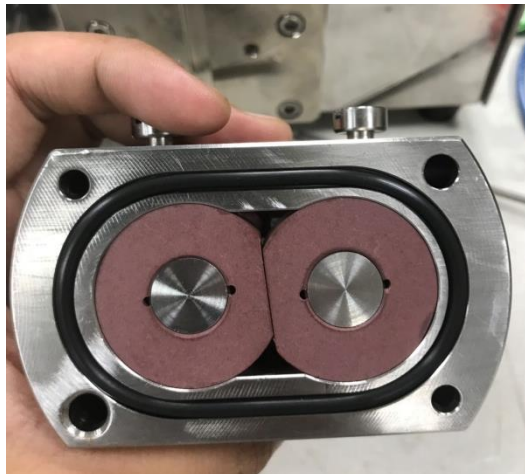



5.1.10 Assemble the back plate

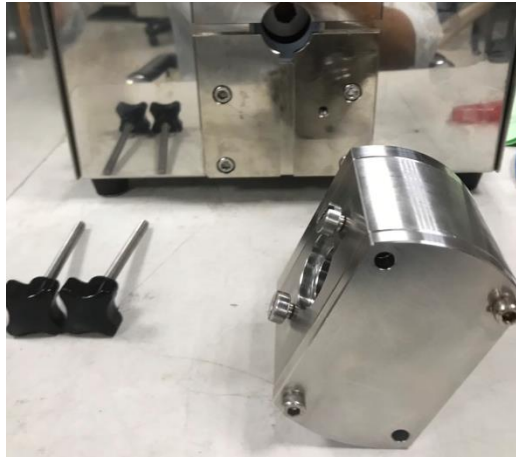

***The gear pump is hexagon, make sure assemble in the right position.**

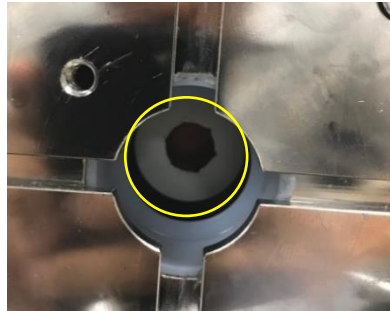



5.1.11 Assemble the screws



5.2 Nozzle assembling

5.2.1 Steel ball nozzle

5.2.1.1

Put the steel ball on the top of spring





5.2.2.2

Assemble the spring/steel ball/
gasket and



5.2.2.3

Assemble the clamp and tighten it.



5.2.2 Air nozzle

5.2.2.1

The components of air nozzle





5.2.2.2

Assemble filling needle into tube

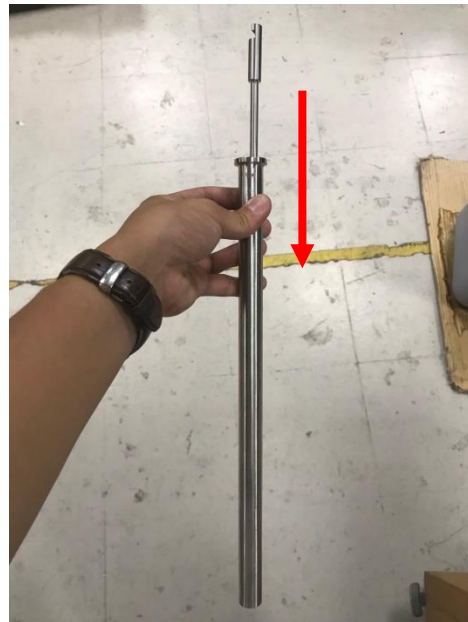

5.2.2.3

Assemble the gaskets



5.2.2.4

Assemble the clamp and tighten it.





5.2.2.5

Assemble grease seal



5.2.2.6

Assemble the cylinder and screw

(Make sure the latch is on the correct position)





5.3 MAINTENANCE

- 5.3.1 Be sure to dry the hands before operating the machine for setting and adjusting to prevent from getting electric shocks or causing short circuit.
- 5.3.2 Avoid filling materials that is higher than 80°C because liquids with higher temperature will cause resistance overloading of the control components and then affect the life span of the machine.
- 5.3.3 After filling, please be sure to clean the hoses and the pump to keep the machine clean.
- 5.3.4 If you need to fill liquids with “granule” please filter before filling in case the granule may block the filler and shorten the life span of the machine.
- 5.3.5 Please be cautious while filling acid or alkaline liquids to prevent from splashing to hurt the operator(s) and the machine.



6 TROUBLESHOOTING

Trouble(s)	Possible Causes & Solutions
Out of Power	<ol style="list-style-type: none"> 1. Check if the power switch is ON. (switch to “ - ”) 2. Check if the emergency button is ON. 3. Check if the power supply cable is loose or broken. 4. Check if the safety fuse blows.
No Reaction	<ol style="list-style-type: none"> 1. Check if the operation mode is Auto Mode. 2. Check if the filling speed is too low. 3. Check if the filling volume is too small. 4. Check if the machine status is stand by. 5. Repeat the setting and filling processes. 6. Check if using a foot pedal or any manual operation assisting devices. Once using those devices, the filler will adopt the signal from them in priority.
Bubbles Appear in Tubes	<ol style="list-style-type: none"> 1. Be sure to eliminate air from the hose before filling. 2. Check if the inlet hose is immersed in the tank. 3. Check if the hose is fastened. 4. Check if the hose is broken.
Strange Noise/ Not Filling Smoothly	<ol style="list-style-type: none"> 1. Check if anything blocks up the pump.

- In case there is any problem or malfunction that you cannot solve, please contact us immediately.



7 CONTACT INFORMATION

If you have any questions or you need to order some spare parts, please contact us through the contact information below:

Tel: **866-888-6327**

E-mail: support@clevelandequipment.com

Website: www.clevelandequipment.com



**Cleveland
Equipment**