

SB-2HD

Side Belt Case Taper

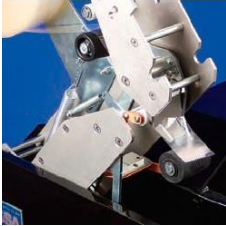

Output	30 cases/per minute* depending on box size and operator efficiency
Min Box Size	4.5"L x 4.0"W x 2.0"H
Max Box Size	∞L x 20"W x 25.5"H
Air Supply	None
Belt Speed	72 feet/per minute
Conveyor Adjustable	
Height	22.5" to 30.5", add 3" for casters if needed
Drive	Dual drive motors
Power Supply	110 VAC, 60Hz, 5.0A

The SB-2HD's side belts are great for light or heavyweight, narrow or small boxes. The system is ideal for void fill cases where the packaged product does not support the box. SB-2HD is designed to handle boxes that most other case tapers can't. SB-2HD offers fast and easy case changes with adjustable side rails and flexibility for boxes 4.5" long and greater. Adjustments can be made on the fly with easy hand tighten knobs and cranks. SB-2HD utilizes Easy-Taper Quick-Load top and bottom tape cartridges and will seal boxes as narrow as 4" wide and as low as 2" tall, where most standard case tapers are only able to tape at a depth of 3" or greater. The SB-2HD can be supplied to operate from left to right at no additional cost, and does not require air to run. Dual drive motors and aggressive industrial strength drive belts make SB-2HD a workhorse that will stand up to your toughest challenges. Each case taping machine is made from 12 gauge steel that will withstand even the most rugged applications. A powder coated exterior protects the machine from abusive conditions and guarantees years of use.



Cleveland Equipment

866-888-6327

sales@clevelandequipment.com

www.clevelandequipment.com

SB-2HD Side Belt Case Taper

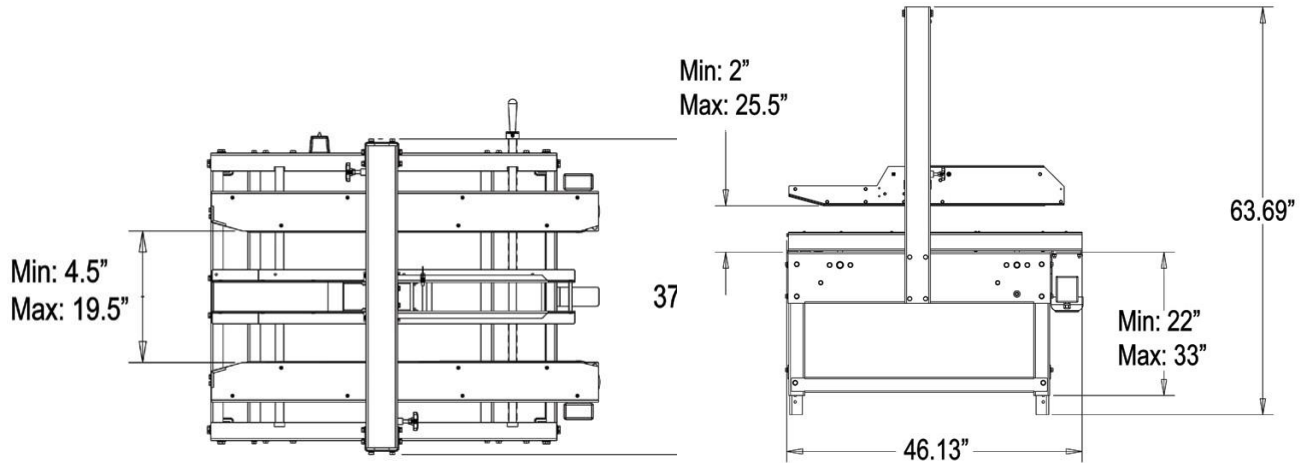

SB-2HD FEATURES	SB-2HD TAPING SPECIFICATIONS				
<ul style="list-style-type: none"> • Plug-in and go operation • Powder coated 12 gauge steel • Interchangeable top and bottom tape cartridges • Industrial strength side belts • Adjustable leg extensions • Fast and easy box size changes • No air required • Low maintenance • Accommodates wide box size change 	Sealer Type	Side belt, top and bottom case sealer			
	Machinery Makeup	Industrial strength 12 gauge steel, powder coated for			
	Belt Speed	72 feet/per minute			
	Tape Speed	30 cases/per minute, depending on box size and operator			
	Height Adjustment	Standard adjustable legs for 22.5" to 30.5" conveyor heights			
	BOX SPECIFICATIONS	Length	Width	Depth	
	Minimum Box Size	4.5"	4.0"	2.0"	
	Maximum Box Size	Infinite	20"	25.5"	
	Tape Size	2" wide pressure sensitive tape, up to 15" diameter rolls, optional 3" wide tape			
	Tape Cartridge	Proven design requires no lubrication, tips back for simple tape threading, removable for maintenance and interchangeable with top or bottom cartridges			
Air Requirements	None				
Electrical Requirements	110 VAC, 60Hz, 5.0A				
SB-2HD OPTIONAL ACCESSORIES					
Front Packing Table	Solid table bolts before taping system to allow for case packing				
Casters	Rugged wheels for transportation within plant				
Top Squeezers	Designed to stabilize the box and push the top flaps together for easier taping				
Stainless Finish	Complete stainless finish to meet specific application requirements				



Cleveland Equipment

866-888-6327

sales@clevelandequipment.com

www.clevelandequipment.com



Cleveland Equipment

866-888-6327

sales@clevelandequipment.com

www.clevelandequipment.com