



# Cleveland Equipment

## SB-2HD

Side Belt Case Taper

## Operation Manual



866-888-6327

[sales@clevelandequipment.com](mailto:sales@clevelandequipment.com)

4403 Delp Street

Memphis, TN 38118

[www.clevelandequipment.com](http://www.clevelandequipment.com)



# Contents

<b>Safety</b> .....	<b>3</b>
<b>Introduction</b> .....	<b>4</b>
SB-2 HD Overview .....	4
Specifications .....	5
<b>Installation and Setup</b> .....	<b>7</b>
Removing the Shipping Pallet.....	7
Repositioning Width Adjustment Handle.....	8
Installing the Optional Locking Casters .....	9
Set Machine Height .....	10
Location Requirements .....	10
Loading the Tape Cartridges.....	11
<b>Operation</b> .....	<b>17</b>
<b>Adjustments</b> .....	<b>18</b>
Package Width.....	18
Package Height.....	18
<b>Maintenance</b> .....	<b>19</b>
Rollers.....	19
Cutting Knives.....	19
Changing the Drive Belts .....	20
<b>Parts List</b> .....	<b>22</b>
SB-2 HD Main Assembly .....	22
Base Frame Assembly, Top.....	24
Base Frame Assembly, Bottom.....	25
Case Support Assembly .....	26
Width Adjustment Assembly.....	27
Vertical Column With Height Adjustment .....	28
Electrical Switch, Strain Relief & Column Attachment .....	29
Upper Tape Head Seat Plunger Pin, CF Spring & Spacer .....	30
Upper Tape Head Seat to Column Assembly.....	31
Side Belt Frame, Idler Pulley, and Tension Brackets.....	32
Side Belt Motor, Motor Pulley, and Attaching Hardware.....	33
Side Belt Guide Strips and Attaching Hardware .....	34
Side Belt Belts, Tensioning & Frame Attaching Screws .....	35
Side Belt Cover & Cover Attaching Screws .....	36



## Safety

Before installing, operating or servicing this equipment, please read the following precautions carefully:

- This machine is equipped with moving belts. Do not place hands near the belts when they are moving as fingers may be pinched where belts enter the frame. We suggest the use of a roller-type exit conveyor or pack table for your cases. Always remove boxes after they clear the exit end of the machine.
- Observe caution when near the tape heads or when threading tape. The tape cutting knife is very sharp, automatically operated, and is linked to the wipe down rollers.
- Always disconnect electrical power before attempting maintenance for any electrical or moving parts. Do not attempt to open or work on the electrical box, junction boxes or other electrical components of the unit without first disconnecting power to the machine. Electrical shock hazard exists if power is not disconnected.
- Use only the specified power-supply cable. Do not use the power cable to pull or position the machine, as this will damage or break the cable.
- Do not bypass any factory-designed safety features such as knife guards, interlocks, switches, etc. Do not operate a machine if such modifications have been made.
- Do not attempt to operate the machine with loads that exceed the limits of use and operation in regards to weight and sizes, or with unstable loads that present a hazard of tipping or falling.
- This equipment is designed for indoor operation in a typical clean, dry factory environment. Do not operate the machine in any extremely wet or oily environment that may exceed operating specifications.
- Do not place hands, head, or any part of the body inside the confines of the machine unless the tape head mechanisms are securely fastened, and the electrical supply is shut off. Do not stand or climb on any part of the taper.
- To minimize the potential for personal injury, always be sure that the machine operators and others working on the machinery are properly trained in the correct usage of this equipment and properly instructed regarding safe operation.
- Never provide service or clear a box jam when machine is running. Always stop the machine and shut off power before servicing.
- When feeding a box into the unit, always hold down the box top and present the box to unit. Release hands as soon as the belts begin to take the box.
- Do not wear loose clothing such as ties, scarves, jewelry etc. Long hair should be pulled back and/or covered while operating this machine.



# Introduction

## SB-2 HD Overview

The side belt driven SB-2 HD is a case taper that is designed to tape the tops and bottoms of uniform sized boxes at rates determined by the operator.

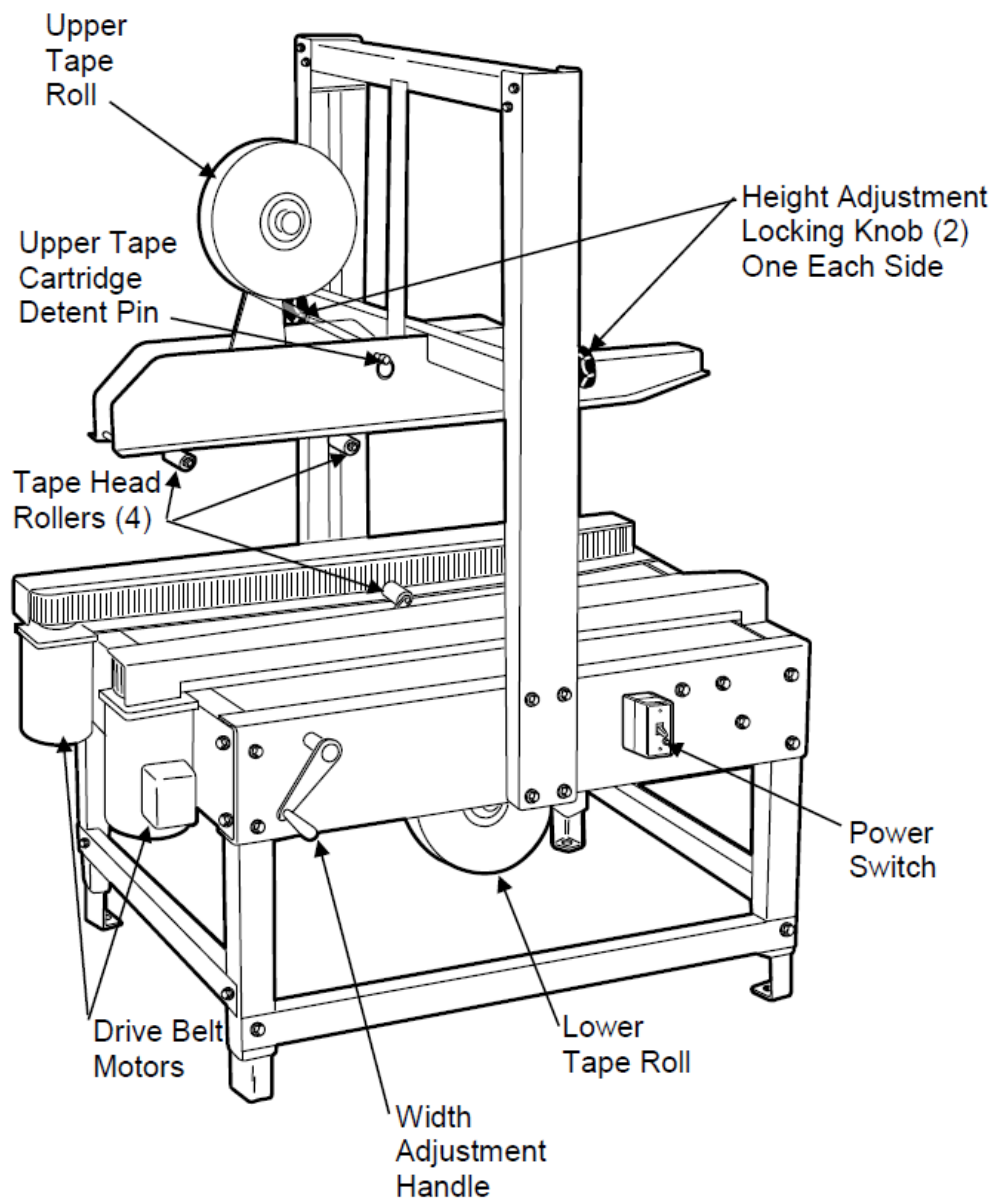



## Specifications

Model	SB-2 HD
Tape	1.5 inches (3.6 cm) or 2 inches (5 cm) up to 15 inches (36 cm) diameter rolls
Machine size	Width (A) 37.32 inches (94.79 cm) Height (B) Min. 52.69 inches (133.8 cm) without optional casters Height (B) Max. 63.69 inches (161.8 cm) with optional casters Length (C) Min. 46.13 inches (117.2 cm) without packing table Length (C) Max. 62.38 inches (158.4 cm) with packing table

## Dimensions

Dimensions shown in inches.

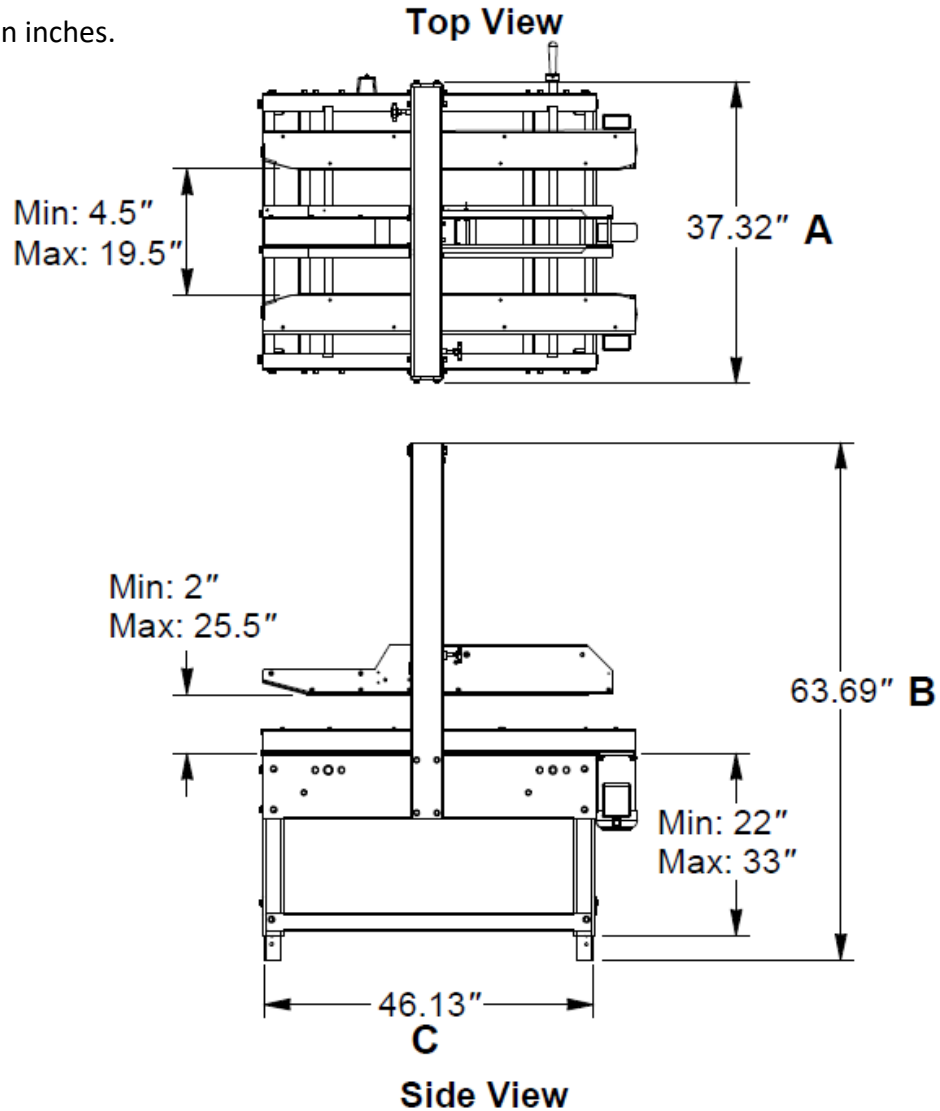



## Standard Features

- Powder coated 12 gauge steel construction
- Industrial strength side drive belts
- Adjustable leg extensions
- Plug-in and go operation
- Fast and easy box size changes
- Accommodates wide box size changes
- No air required
- Low maintenance

## Options

- Packing table
- Set of four locking casters

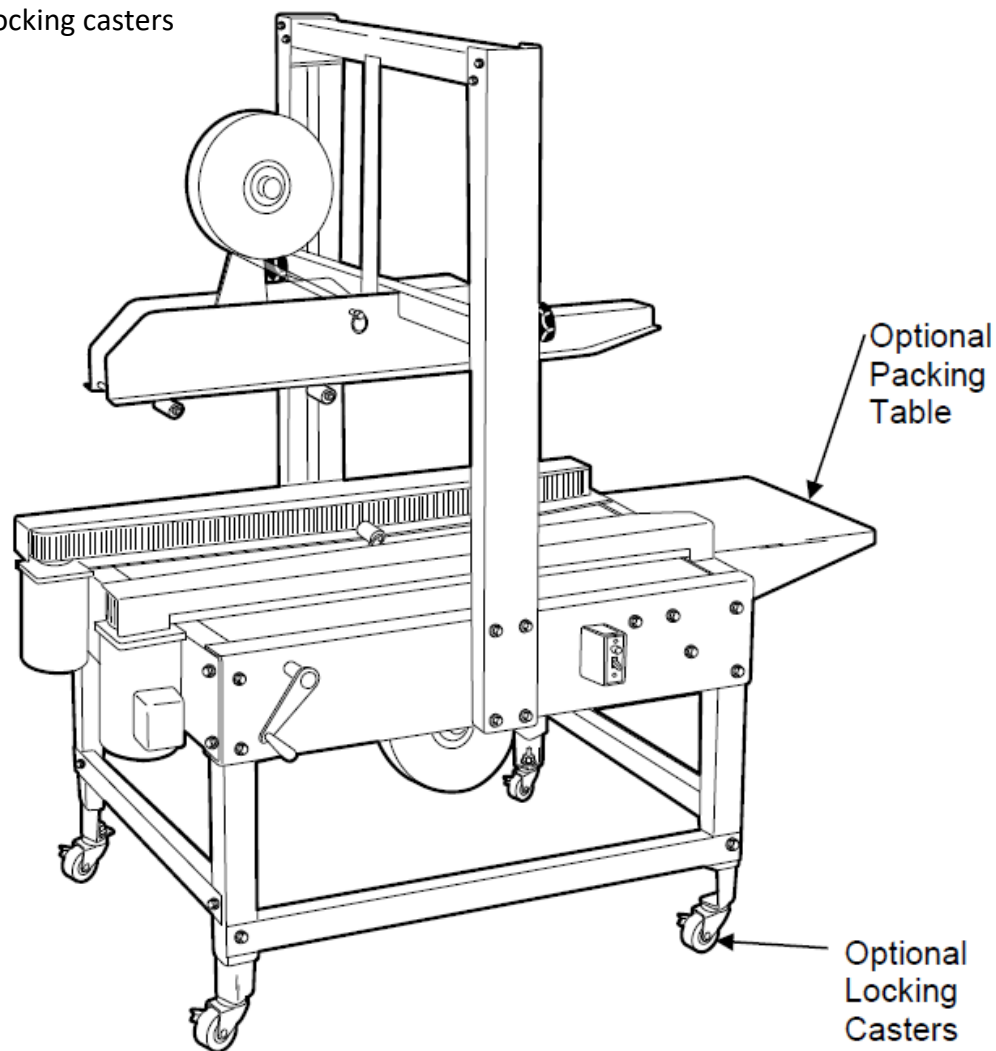



# Installation and Setup

## Removing the Shipping Pallet

Unfasten the four shipping bolts that secure the SB-2 HD to the shipping pallet and lift the SB-2 HD Case Taping System from the pallet.

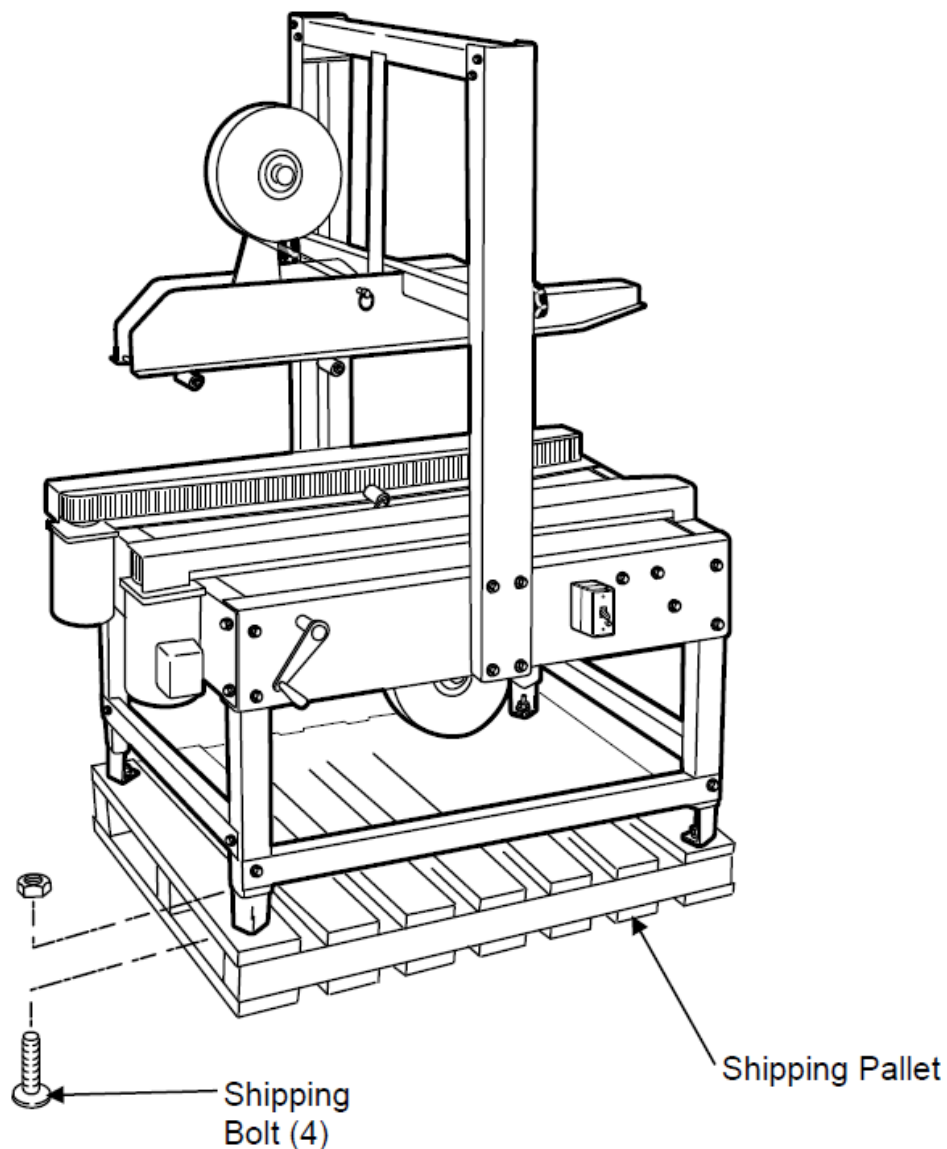

Lift the SB-2 HD Case Taping System from the pallet.

**CAUTION!** The SB-2 HD Case Taper is a very heavy piece of equipment and will require a forklift, floor crane, or several people to move safely off the shipping pallet. Use proper equipment when lifting the case taper and ensure the case taper is secure and will not shift while the shipping pallet is being removed or during height adjustment or optional caster installation.



## Repositioning Width Adjustment Handle

The width adjustment handle is shipped in the shipping position and must be reversed to the operating position.

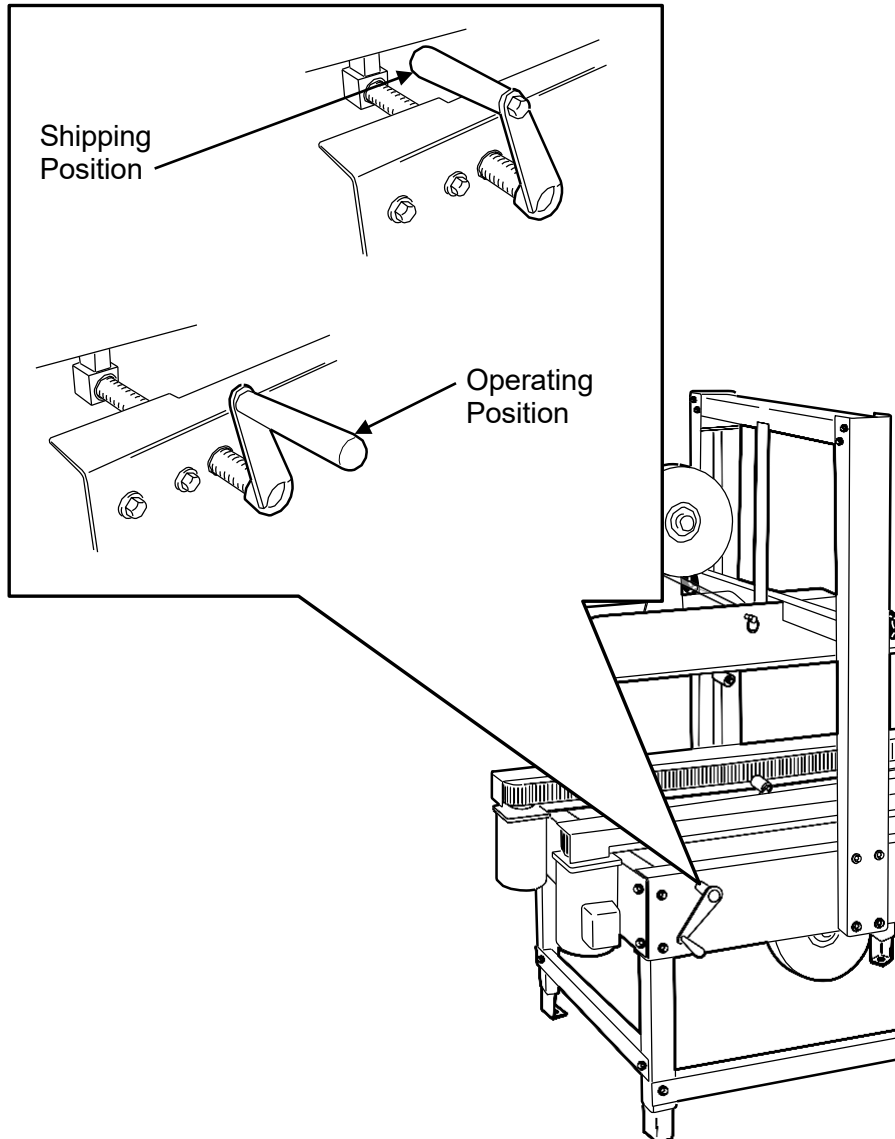



## Installing the Optional Locking Casters

If you have purchased the optional locking casters install them on the four taper legs.

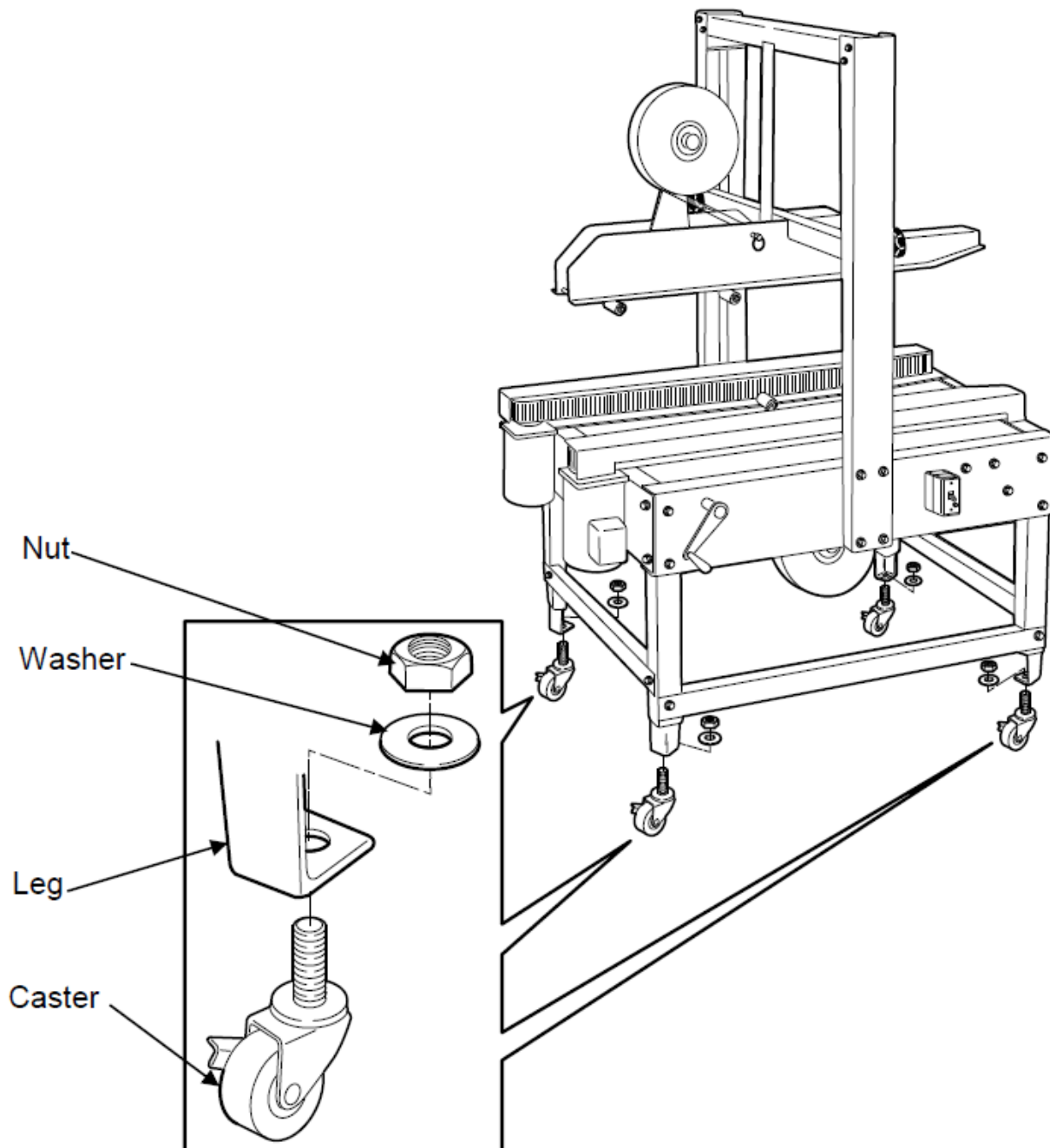

**CAUTION!** When raising the case taper off the floor to install the casters, use proper equipment to lift the case taper. Ensure the SB-2 HD Case Taper is secure and will not shift while the casters are being installed.



## Set Machine Height

To adjust the leg height, loosen the screws shown on each leg. Slide the insert up or down to the required height, and then refasten the screws.

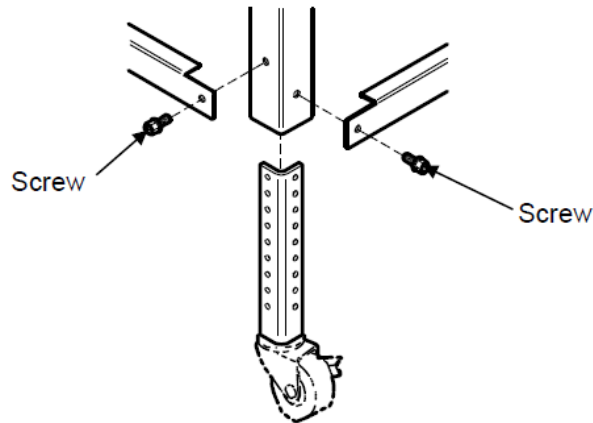

## Location Requirements

To move the SB-2 HD to the desired location, you will need to use a pallet jack or fork lift. If you have purchased the optional locking casters you can move the taper easily over a smooth flat surface.

When installing the SB-2 HD Taping System please be aware of the following considerations:

1. The mounting surface is flat and level.
2. Conveyor or packing table height.
3. Alignment with packaging line.

When the SB-2 HD Taper is installed in the operating location you will need access to:

1. The power switch.
2. Height and width adjustments.
3. Tape loading (Both upper and lower tape cartridges).

A packing table may be provided at the in-feed end where the packer can fill boxes and close the flaps prior to feeding the boxes into the machine. It may also be convenient to place a separate table, bin, or exit conveyor near the exit end of the taper for handling of sealed cases.

It is essential that the table and conveyor be at the machine bed height.

The machine should be placed on a flat, level floor so that it does not rock or move. Optional locking casters are available to provide portability; however, we recommend that the machine be securely locked in place when used.



## Loading the Tape Cartridges

Turn the main power off and disconnect power.

**CAUTION!** To avoid personnel injury, remove the tape cartridge before loading tape.

**When handling the tape cartridge be careful to avoid contact with the tape cutting blade.**

### Lower Cartridge

To remove the lower tape cartridge, it is necessary to raise the upper taping head to the highest position. Loosen the height adjust locking knobs (there is one on each side of the vertical mast supporting the tape head seat) and raise the upper tape head. Re-tighten the locking knobs.

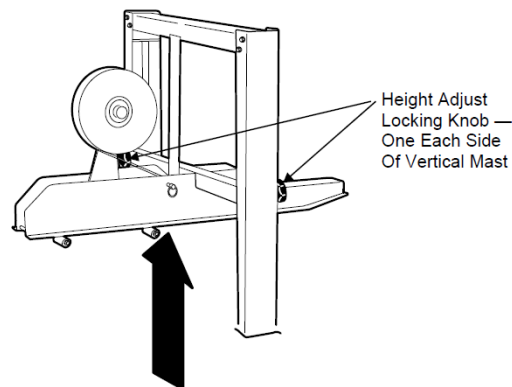

After raising the top taping head up, remove the lower taping cartridge from the bottom section by holding both lift points and lifting leading with the rear lift point first, raising the tape cartridge upward, out of the lower tape head seat.



**CAUTION!** Only lift the tape cartridge by the lift points. Lift leading with the rear lift point first. Take care to keep away from any cutting edges.

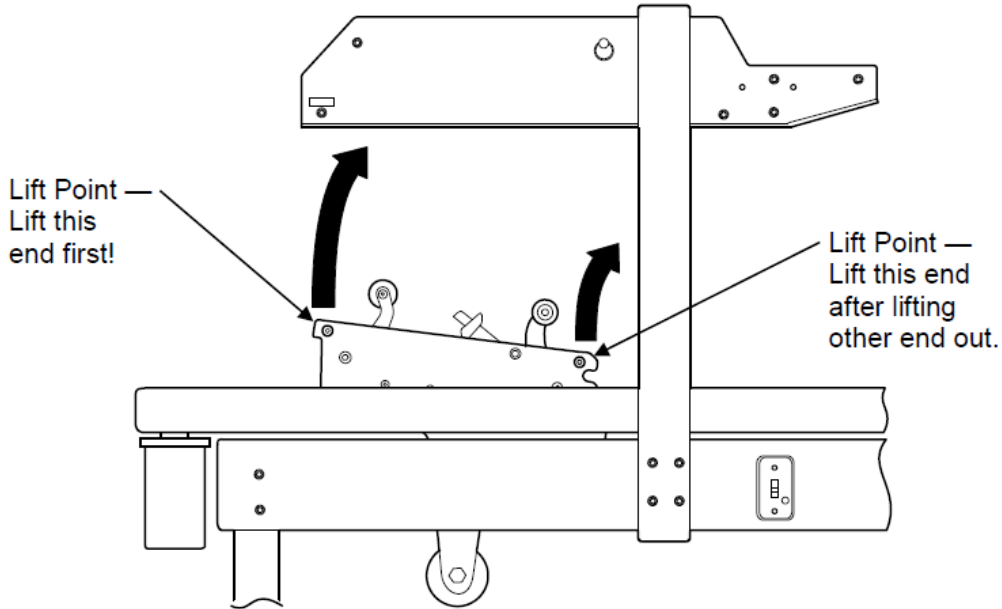

## Prepare the Tape Roll

Push the tape roll onto the tape core assembly.

**NOTE:** Make sure the tape roll is pushed all the way on the tape core assembly.

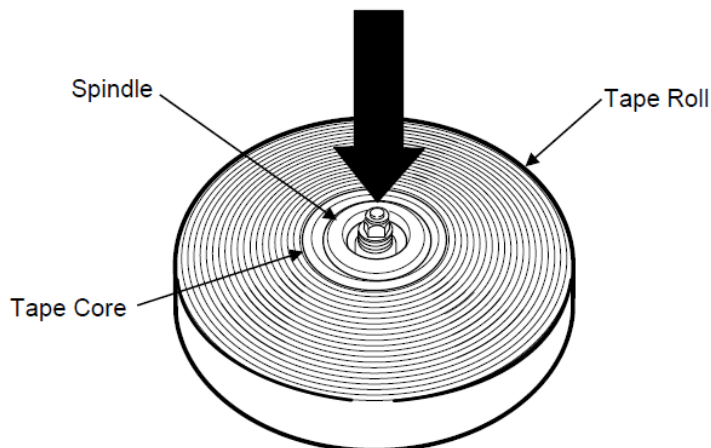



## Check Tension

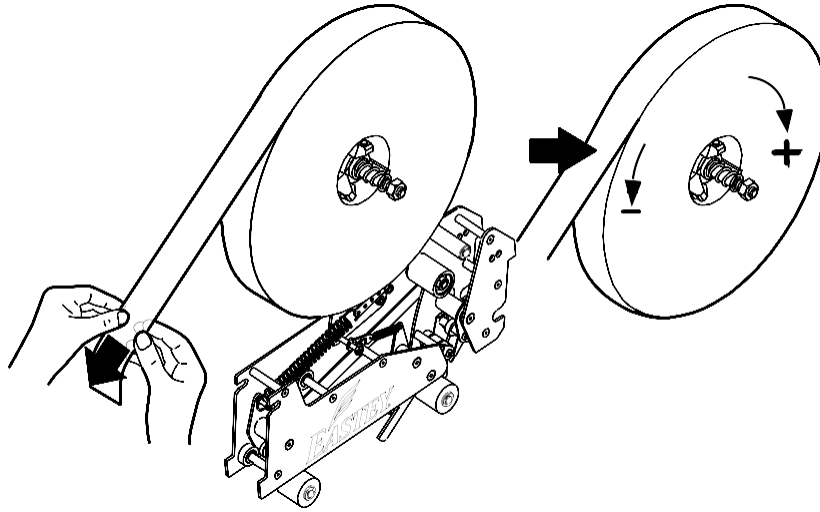

Check the tape for correct tension. If the tape head used with the taper allows for adjustment of tape tension, tighten or loosen the tape core holder to adjust to correct tension.

## Thread Tape

Carefully thread the new tape through the rollers in the tape head as shown in the applicable diagram in the Tape Head User Guide provided with the tape head. Be careful to avoid the cutting edges.

For convenience, the diagram for threading tape in the EZ-EX Tape Head, which is the tape head normally offered with this machine, is provided on the following page. Follow the diagram that applies for your tape head, depending on the tape head model and position when installed in the taper.



### EZ-EX Tape Head

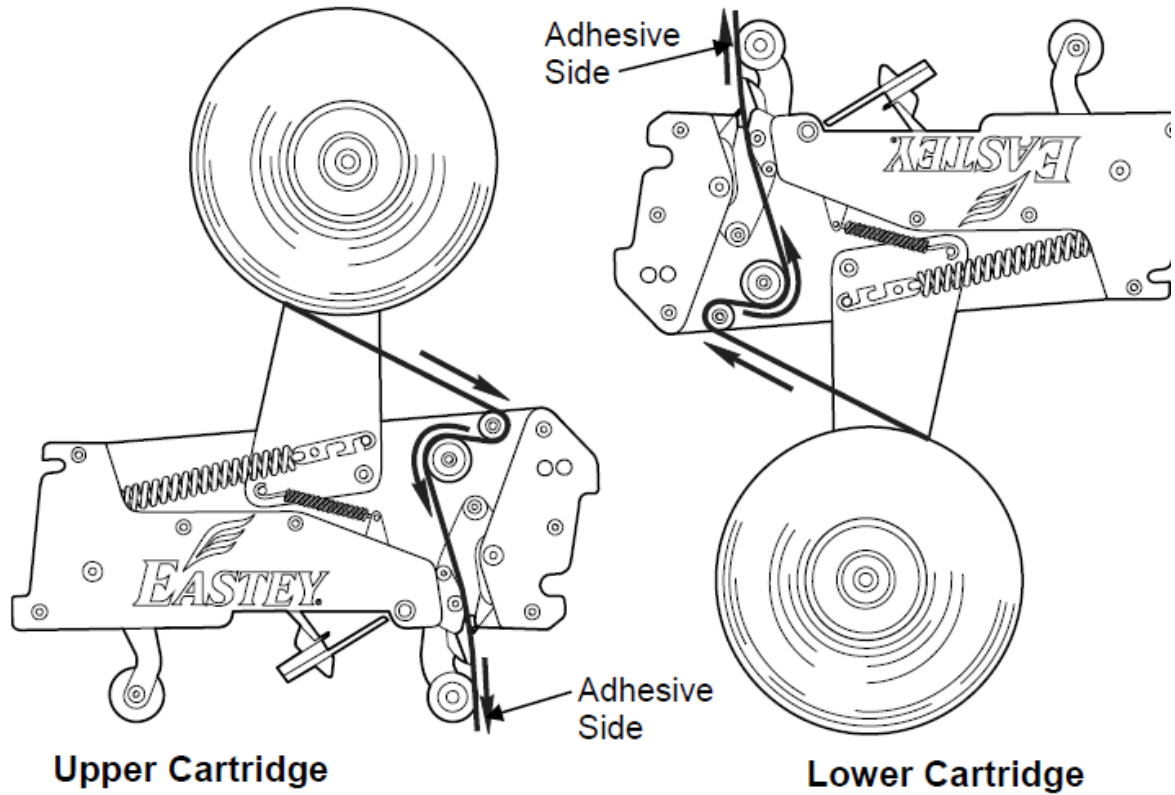

### Reinstall the Lower

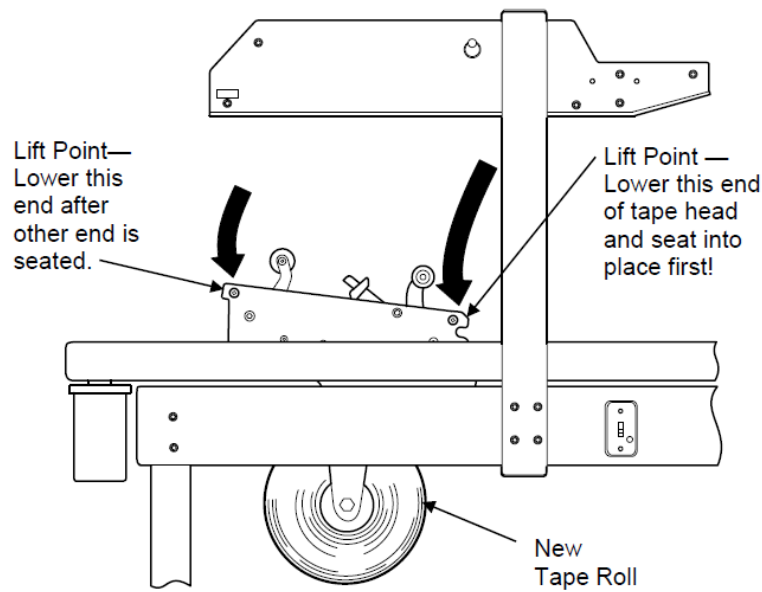



## Upper Cartridge

To remove the upper cartridge, it is helpful to lower the upper taping head to its lowest position. Loosen the height adjust locking knobs (there is one on each side of the vertical mast supporting the tape head seat) and lower the upper tape head. Re tighten the locking knobs. Pull the detent pin and raise the right end of the cartridge first.

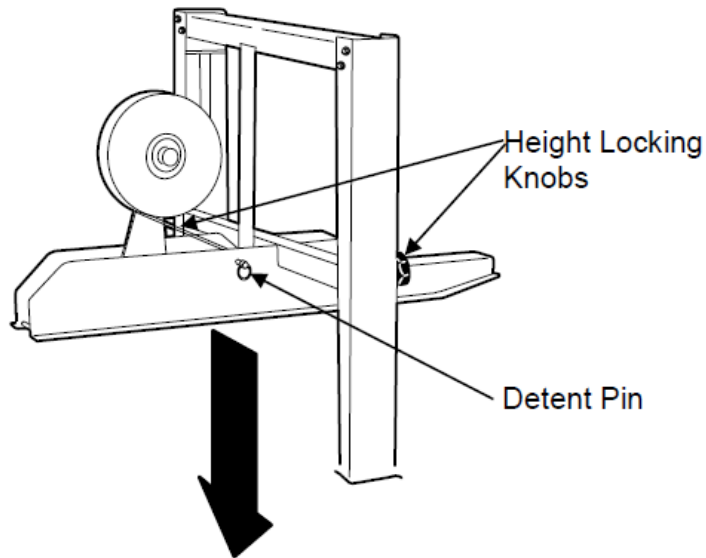

Lift the upper cartridge up and out of the machine.

**CAUTION!** Only lift the tape cartridge by the two lift points. Take care to keep away from any cutting edges.

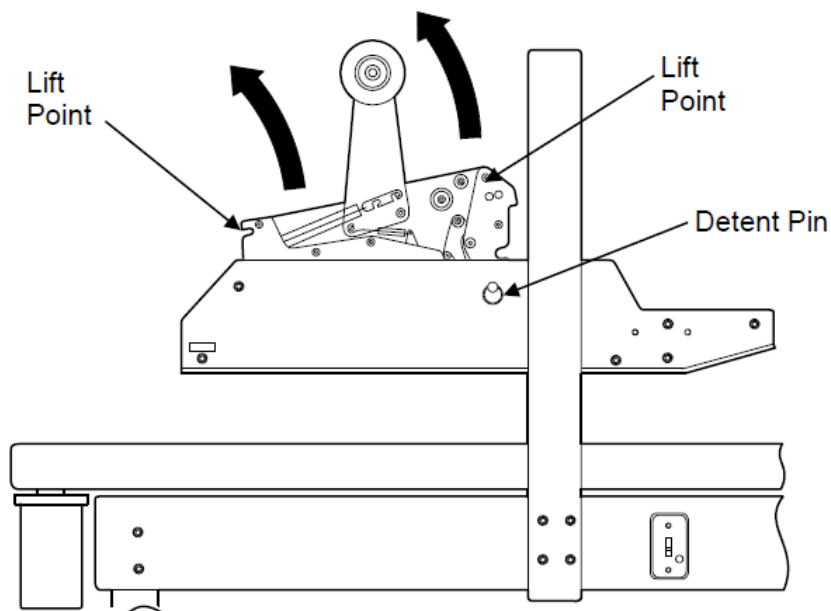



## Thread Tape

Prepare the tape roll, check tape tension, and thread the tape through the rollers in the tape head for the upper tape cartridge following the same instructions provided for the lower tape cartridge.

## Reinstall the Upper Tape Cartridge

Supporting the upper tape head by the lift points indicated, lower the tape head into the machine. Reinstall the detent pin to secure the upper tape head.

**CAUTION!** When replacing the upper tape cartridge only lift by the two lift points. Take care to keep away from any cutting edges.

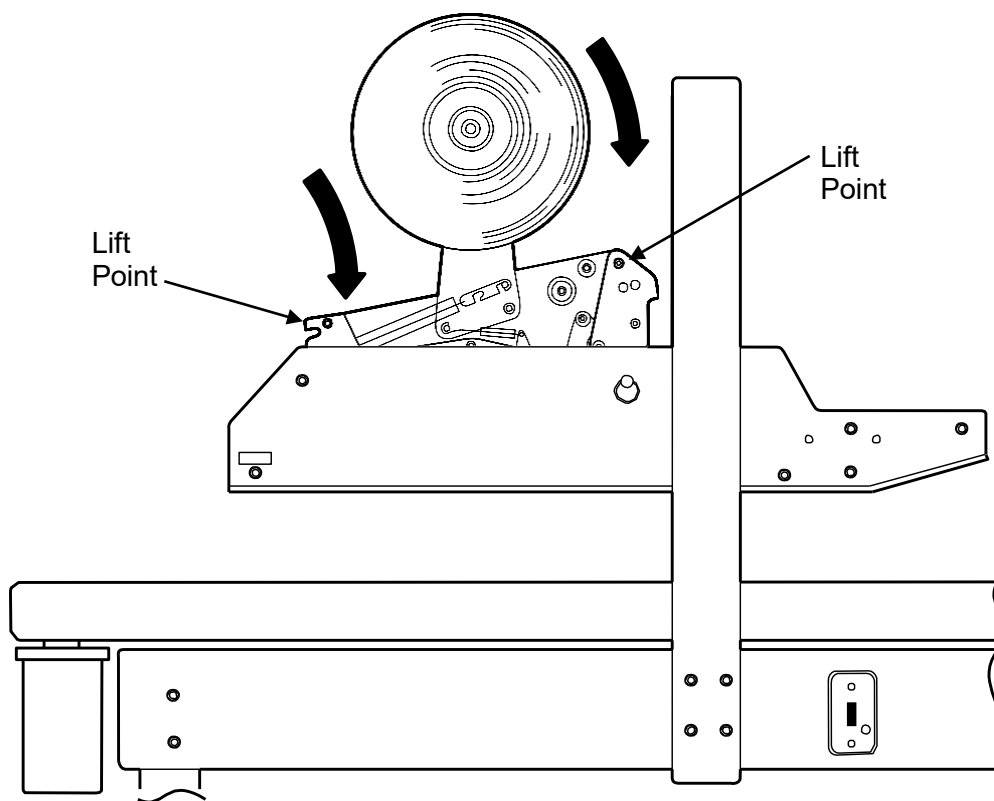



# Operation

The SB-2 HD Industrial Case Taping System is very simple to operate. Before running the taper take a minute to double check your installation. Make sure the taper is at the correct height, is properly aligned with the packaging line and the package height and width adjustments are correct.

Plug the power cord into a properly wired and grounded receptacle. Turn on the power switch.

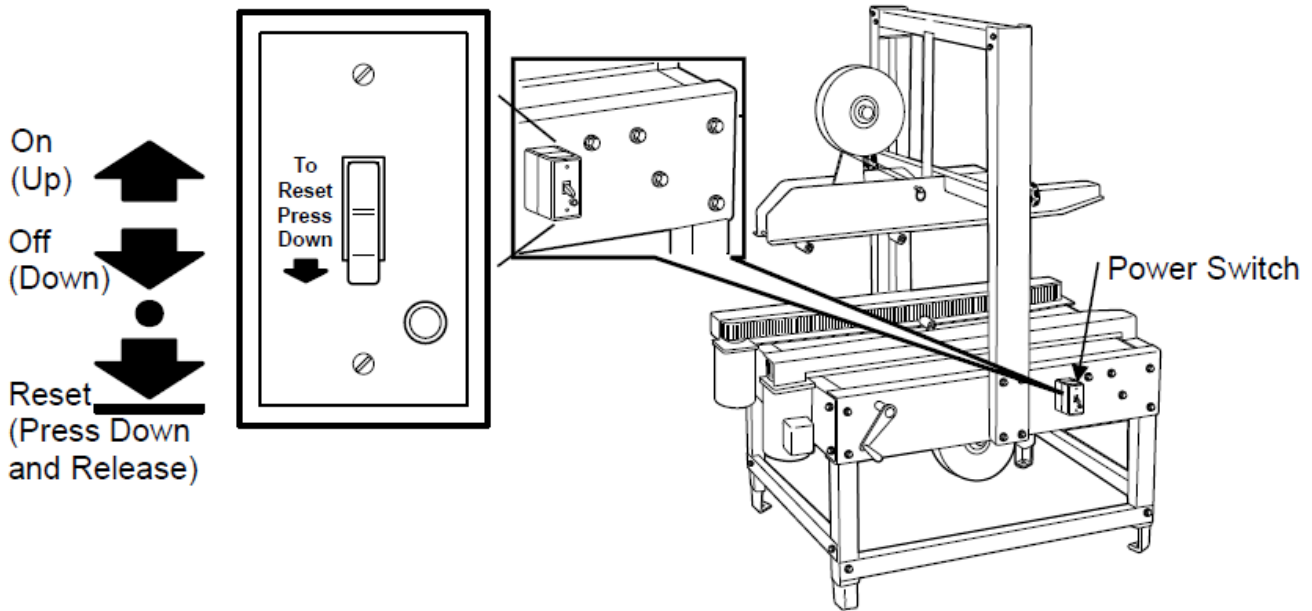

Run a package through the Taper.

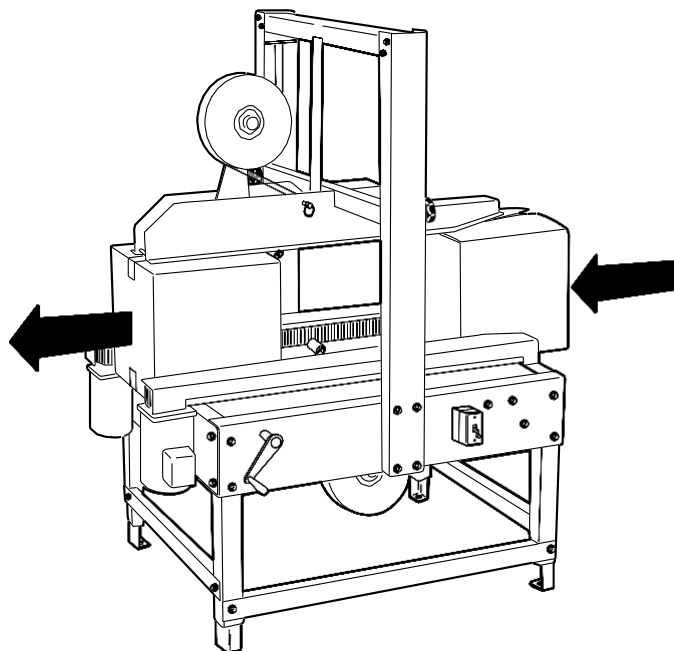



# Adjustments

**CAUTION!** Make all adjustments with the machine turned off.

## Package Width

Adjust drive belt width according to the box width using the width adjustment handle at the side of the case taper.

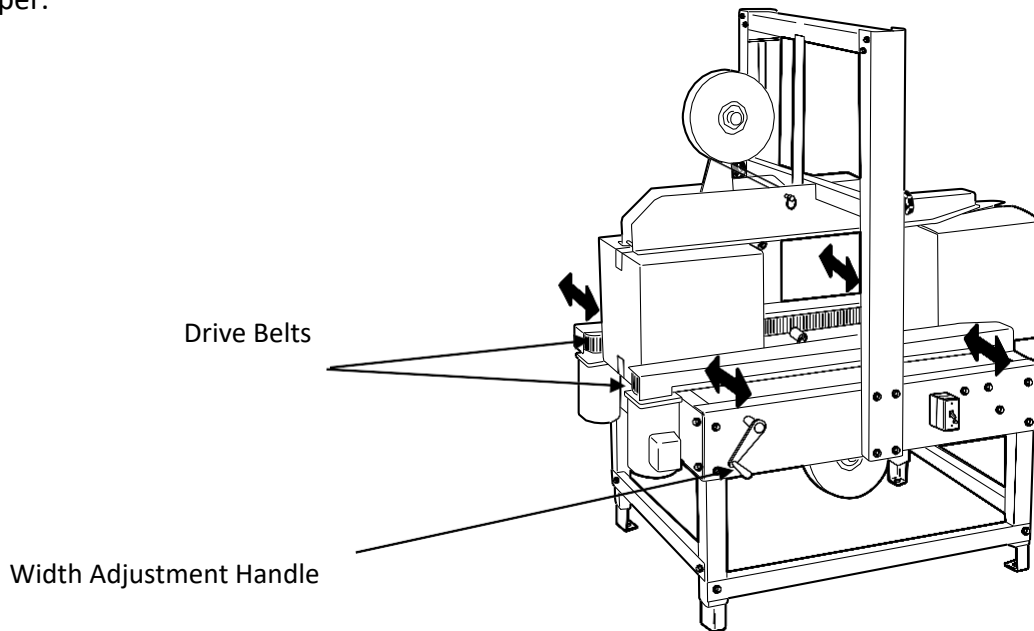

## Package Height

Adjust upper tape head height according to the box height by loosening both height locking knobs, adjusting upper tape head to desired height, and then retightening the height locking knobs.

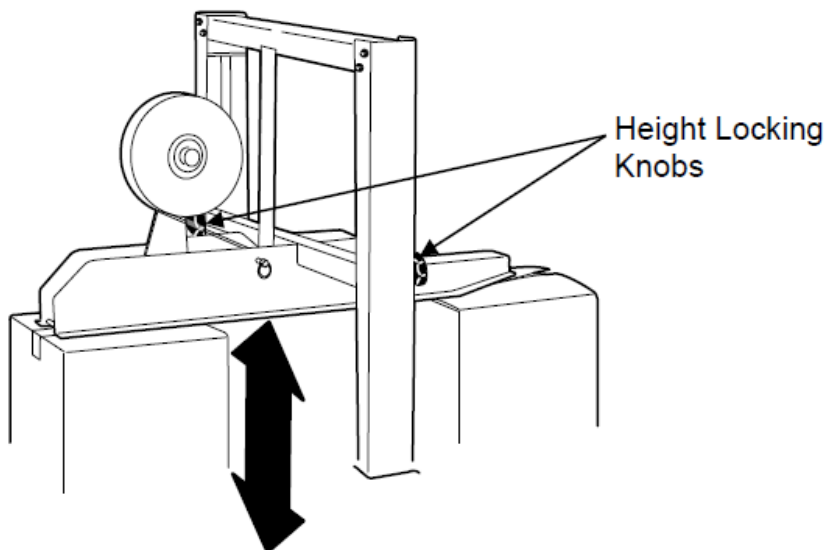



# Maintenance

The SB-2 HD Industrial Case Taping System will provide many hours of maintenance free operation. There are a few items that may require attention from time to time.

## Rollers

Make sure rollers stay clean and grease free. If you should have to clean the rollers simply wipe them down with a clean lint free cloth. If a more thorough cleaning is necessary wipe the rollers down with a mild detergent and water and let dry. **Never use harsh or abrasive cleaners or chemical agents when cleaning the rollers.**

## Cutting Knives

Occasionally inspect the cutting knives to ensure they are clean and free of adhesive residue. Make sure the cutting knife is sharp by inspecting cuts in the tape. Cuts should be straight and neat. If the quality of cuts is eroding, the knife blade is dull and should be replaced.

## Changing Knife Blades — Refer to Tape Head User Guide

Turn off and unplug the taper before inspecting or changing the knife blades. It is not necessary to remove either tape head to change the blade. Refer to the Tape Head User Guide provided with the tape head for instructions for changing the knife blades.

**CAUTION!**      **Always be aware of the cutting edges while replacing the knife blades.  
Handle the knife blades carefully.**



## Changing the Drive Belts

Turn off and unplug the taper.

Remove the eight (8) drive belt cover plate mounting screws and the idler pulley tracking bolt.

Lift the drive belt cover plate off the drive belt assembly.

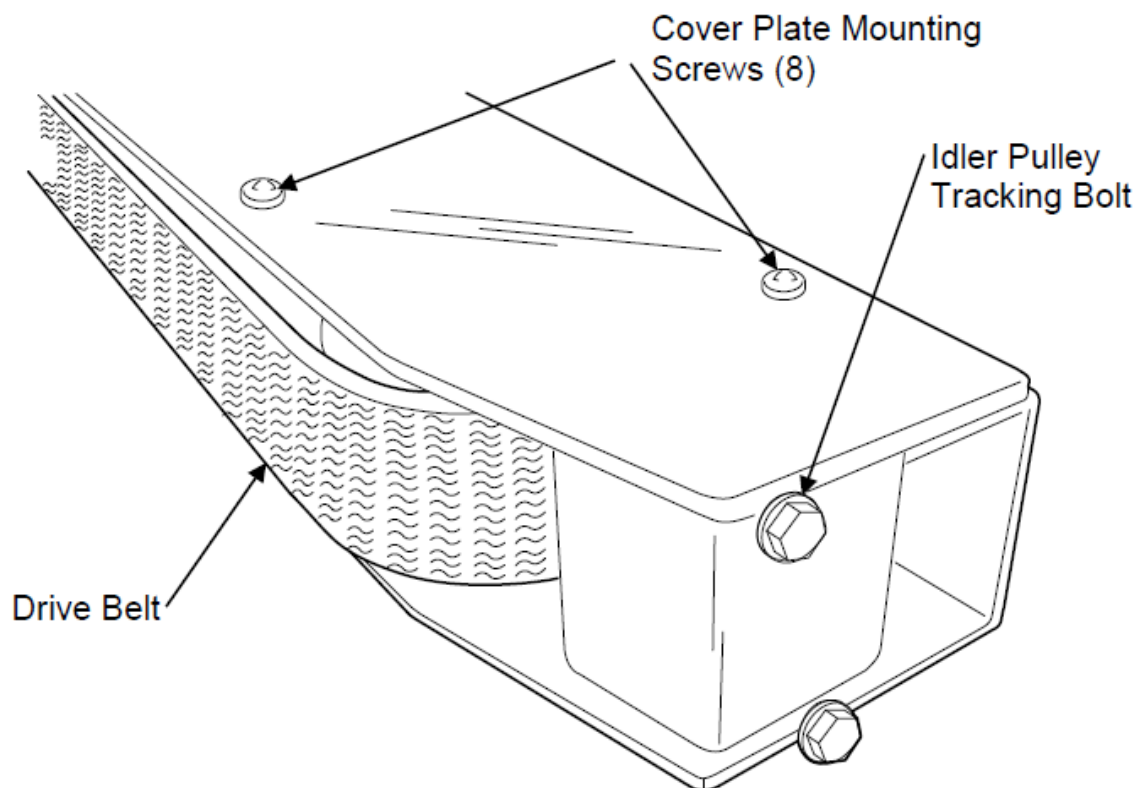



Loosen the idler pulley locking nut located under the idler pulley

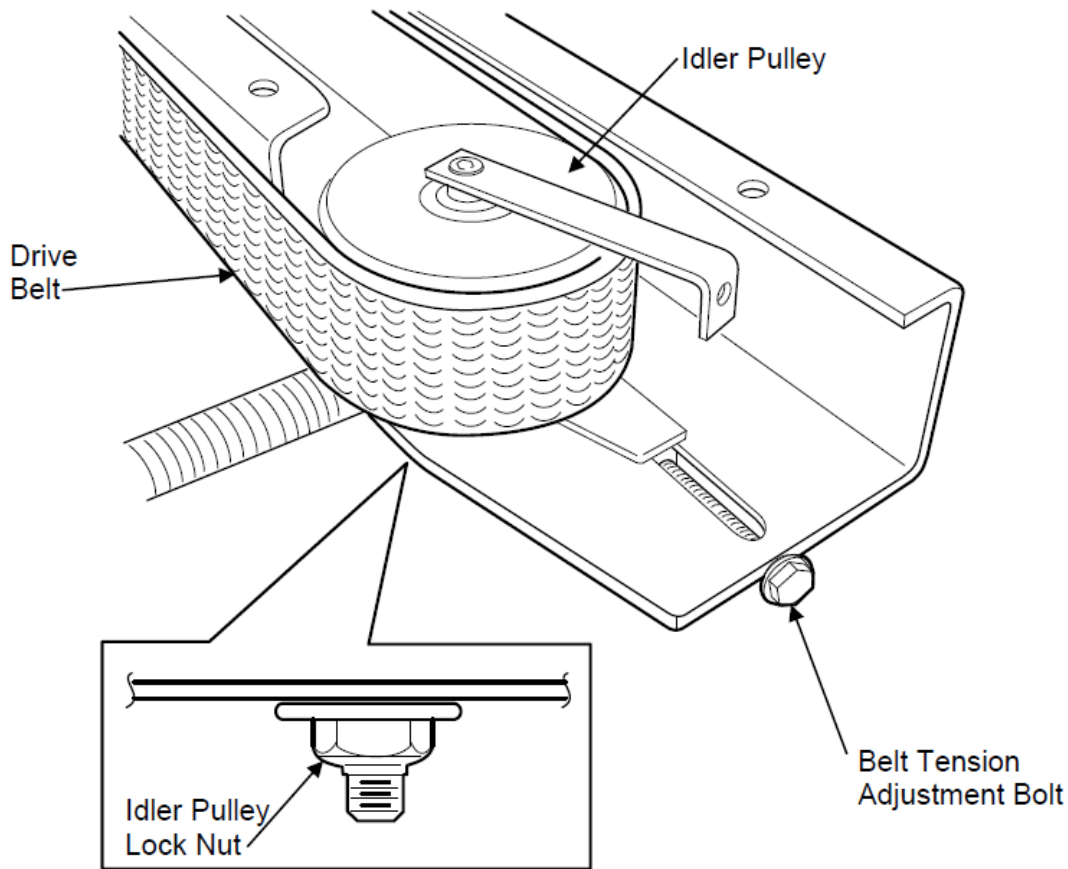

Use the belt tension adjustment bolt to loosen the drive belt enough to remove it from the drive and idler pulleys.

Remove the old belt from around the drive and idler pulleys. Place a new belt around both drive and idler pulleys.

Use the belt drive tension bolt to tight the new belt. Retighten the idler pulley lock nut.

Replace the drive belt cover tracking arm bolt.

Plug in and turn on the SB-2 HD Case Taper to resume taping.



# Parts List

## SB-2 HD Main Assembly

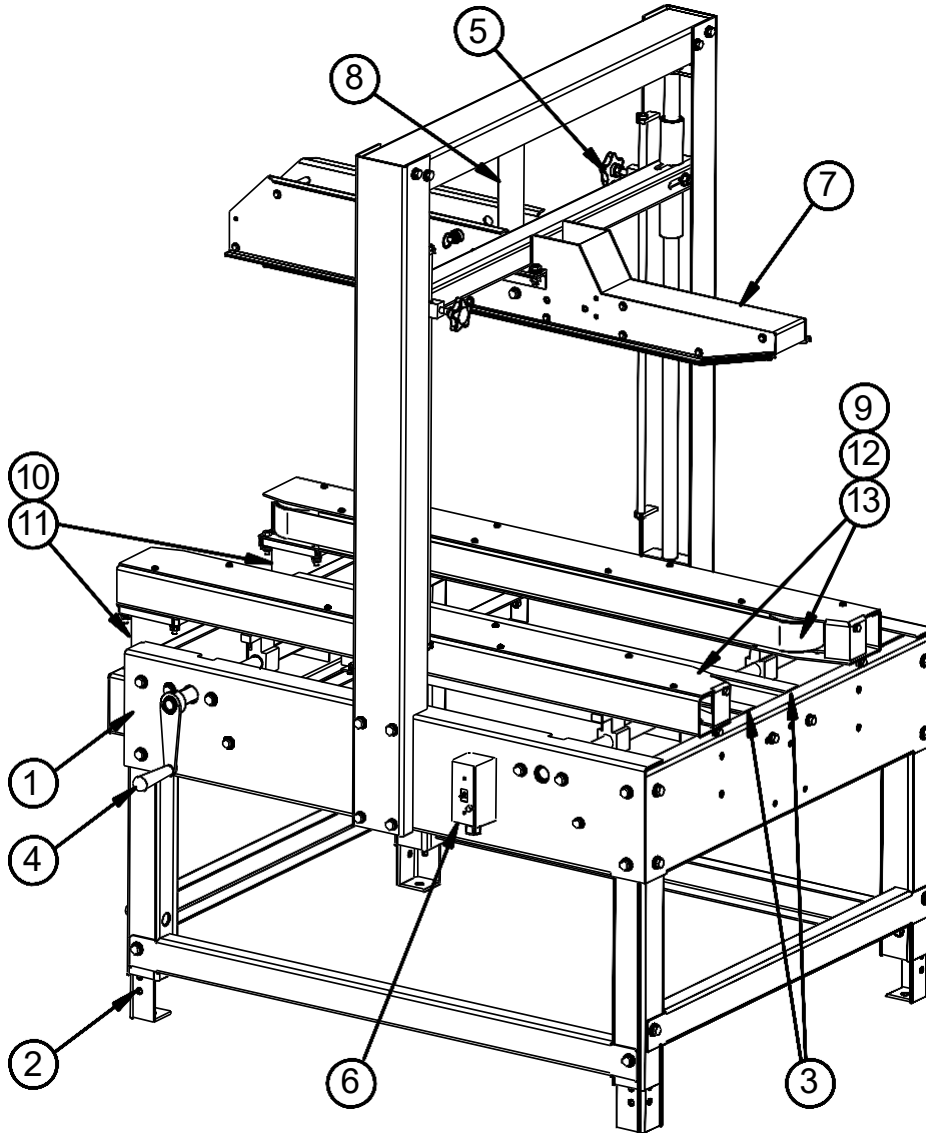

ITEM	DESCRIPTION	PAGE
1	Base Frame Assembly, Top	28
2	Base Frame Assembly, Bottom	29
3	Case Support Assembly	30
4	Width Adjustment Assembly	31
5	Vertical Column With Height Adjustment	32
6	Electrical Switch, Strain Relief & Column Attachment	33



ITEM	DESCRIPTION	PAGE
7	Upper Tape Head Seat Plunger Pin, CF Spring & Spacer	34
8	Upper Tape Head Seat to Column Assembly	35
9	Side Belt Frame, Idler Pulley, and Tension Brackets	36
10	Side Belt Motor, Motor Pulley, and Attaching Hardware	37
11	Side Belt Belts, Tensioning & Frame Attaching	38
12	Side Belt Belts, Tensioning & Frame Attaching Screws	39
13	Side Belt Cover & Cover Attaching Screws	40



### Base Frame Assembly, Top

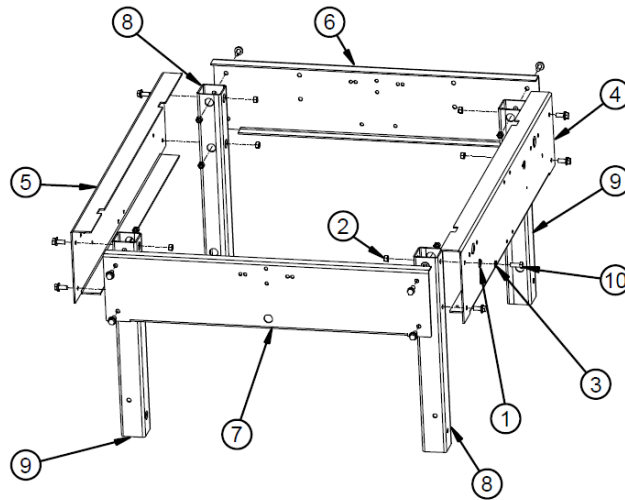

	PART NO.	DESCRIPTION	Q'TY
1	055029-022	WASHER – FLAT $\frac{3}{8}$ " ZINC	16
2	055307-062	NUT $\frac{3}{8}$ "-16 NI	16
3	055310-042	WASHER – SPLIT $\frac{3}{8}$ " NI	16
4	5000548	FAB – SIDE FRAME, LEFT, SB-2/3 HD	1
5	5000549	FAB – SIDE FRAME, RIGHT, SB-2/3 HD	1
6	5000550	FAB – FRONT FRAME	1
7	5000551	FAB – REAR FRAME	1
8	5000552	FAB – LEG, (R/L)	2
9	5000553	FAB – LEG LEFT REAR	2
10	5000791	SCREW – HH $\frac{3}{8}$ "-16 $\times$ 1" NI	16



## Base Frame Assembly, Bottom

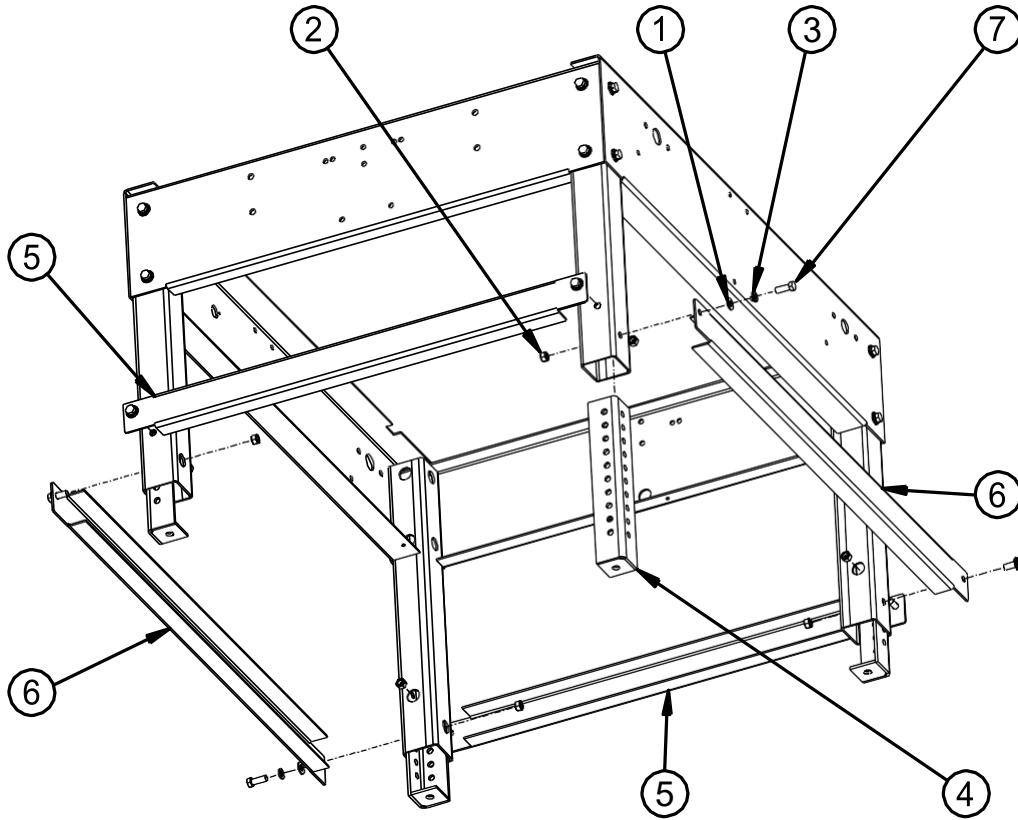

ITEM	PART NO.	DESCRIPTION	Q'TY
1	055029-022	WASHER – FLAT $\frac{3}{8}$ " ZINC	8
2	055307-062	NUT $\frac{3}{8}$ "-16 NI	8
3	055310-042	WASHER – SPLIT $\frac{3}{8}$ " NI	8
4	5000195	FAB/WELD – LEG EXTENSION	4
5	5000554	FAB – BRACE, FRONT	2
6	5000555	FAB – BRACE, SIDE	2
7	5000791	SCREW – HH $\frac{3}{8}$ "-16 × 1" NI	8



## Case Support Assembly

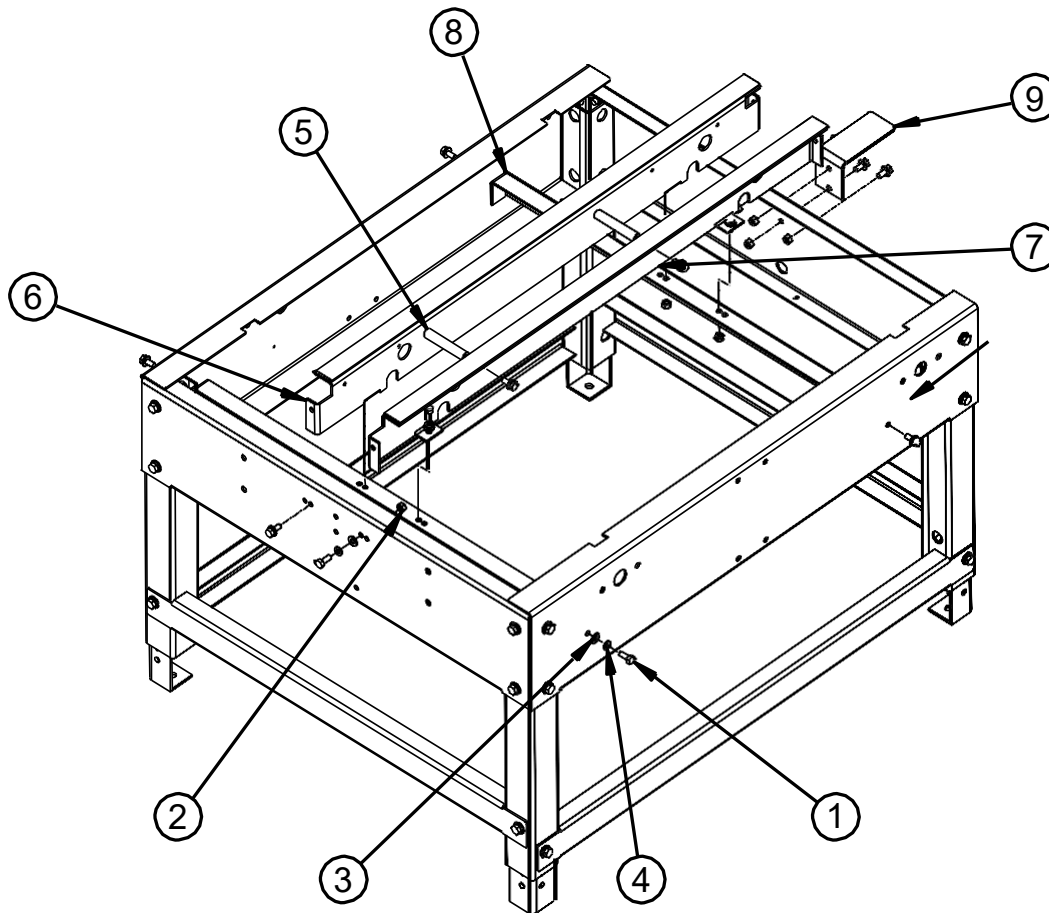

ITEM	PART NO.	DESCRIPTION	Q'TY
1	055293-056	SCREW – HH $\frac{5}{16}$ "-18 $\times$ $\frac{3}{4}$ " ZINC	18
2	055307-055	NUT $\frac{5}{16}$ "-18 ZINC	14
3	5000333	WASHER – FLAT $\frac{5}{16}$ " ZINC	18
4	5000339	WASHER – $\frac{5}{16}$ " SPLIT, ZINC	18
5	5000571	MACH – SHAFT, DRUM, $\frac{5}{8}$ O.D. $\times$ 3.375"	2
6	5000574	FAB/WELD – PRODUCT SUPPORT, LEFT	1
7	5000575	FAB/WELD – PRODUCT SUPPORT, RIGHT	1
8	5000576	FAB – FRAME BRACE	2
9	5000578	FAB – EXIT BRACKET, SB HD	1



## Width Adjustment Assembly

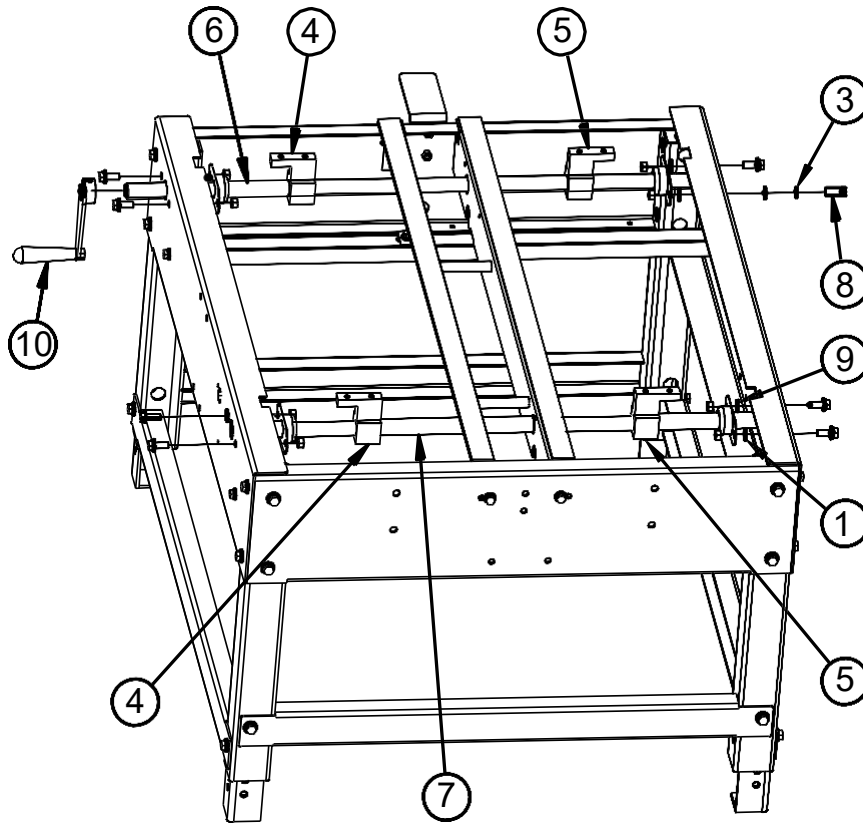

ITEM	PART NO.	DESCRIPTION	Q'TY
1	055029-022	WASHER – FLAT $\frac{3}{8}$ " ZINC	16
2	055307-062	NUT – HEX, $\frac{3}{8}$ "-16 NI	8
3	055310-042	WASHER – SPLIT $\frac{3}{8}$ " NI	8
4	5000542	FAB/WELD – LEAD NUT, LEFT THREAD	2
5	5000543	FAB/WELD – LEAD NUT, RIGHT THREAD	2
6	5000562	FAB – LEAD SCREW, MAIN	1
7	5000563	FAB – LEAD SCREW, IDLER	1
8	5000791	SCREW – HH, $\frac{3}{8}$ "-16 × 1" NI	8
9	5000605	BEARING, FLANGE	4
10	5000612	ASSEMBLY – HAND CRANK	1



## Vertical Column With Height Adjustment

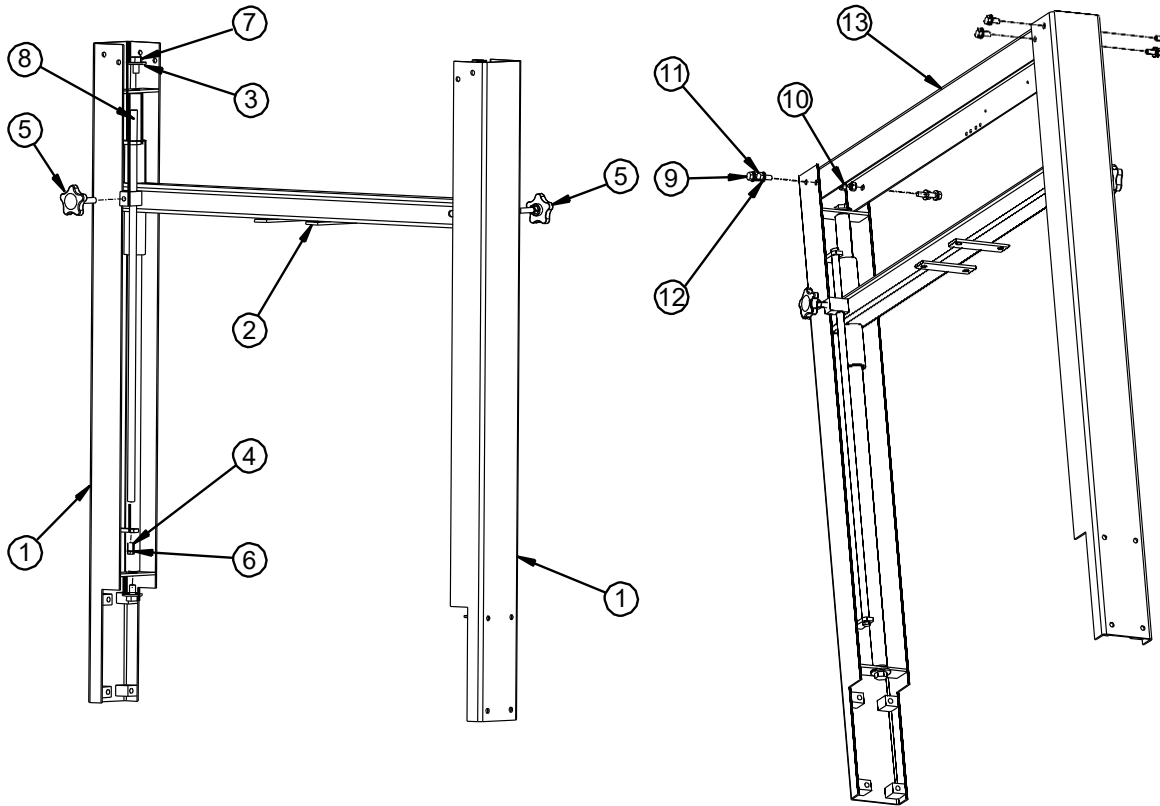

ITEM	PART NO.	DESCRIPTION	Q'TY
1	5000556	FAB – UPRIGHT, SB HD MAST	2
2	5001232	FAB/WELD – SB HD MAST CARRIAGE BEAM	1
3	055029-025	WASHER – FLAT 1/2" CS CAD	4
4	5000542	SCREW – HH, 1/4" 20 x 5/8" SST	2
5	5001284	ASSEMBLY – HAND KNOB	2
6	055455-014	WASHER – LOCK 1/4" EXT ZINC	2
7	5000338	SCREW – HH 1/2"-13 x 3/4" SAE 8	4
8	5000560	MACH – LOCK SHAFT	2
9	055293-056	SCREW – HH 5/16"-18 x 3/4" ZINC	8
10	055307-055	NUT – HEX 5/16"-18 ZINC	8
11	5000333	WASHER – FLAT 5/16" ZINC	8
12	5000339	WASHER – 5/16" SPLIT, ZINC	8
13	5000561	FAB – TOP BRACE	1



## Electrical Switch, Strain Relief & Column Attachment

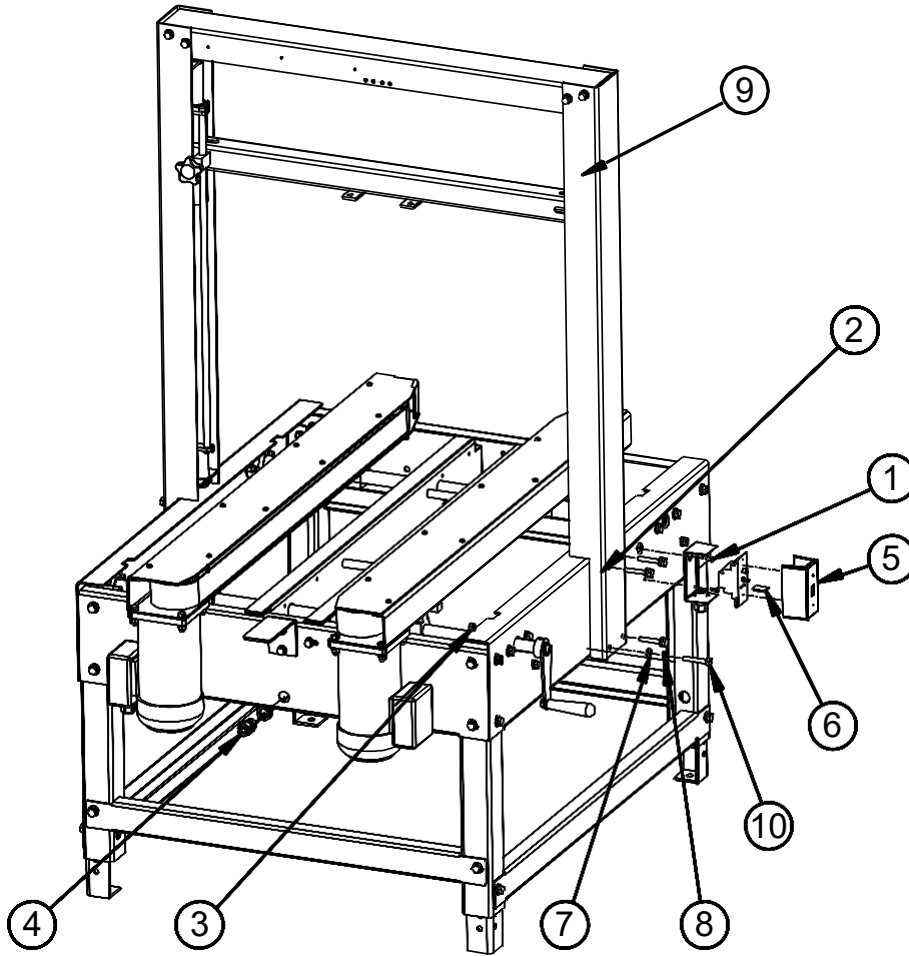

ITEM	PART NO.	DESCRIPTION	Q'TY
1	054979-123	SCREW – PH #10-32 × 0.5" PH SS SEMS – IN	2
2	054382-005	NUT – KEP #10-32 NC ZINC	2
3	055307-055	NUT – HEX, 5/16"–18 ZINC	8
4	1602253	STRAIN RELIEF, VECTOR	2
5	5001264	SWITCH MOTOR ON/OFF	1
6	5001265	FUSE– OVERLOAD 6A	1
7	5000333	WASHER – FLAT 5/16" ZINC	8
8	5000339	WASHER – 5/16" SPLIT ZINC	8
9	5000404	ASSEMBLY – HEAD LIFT, SB-2 HD	1
10	5000688	SCREW – HH 3/8"-10 × 2" NI	8



## Upper Tape Head Seat Plunger Pin, CF Spring & Spacer

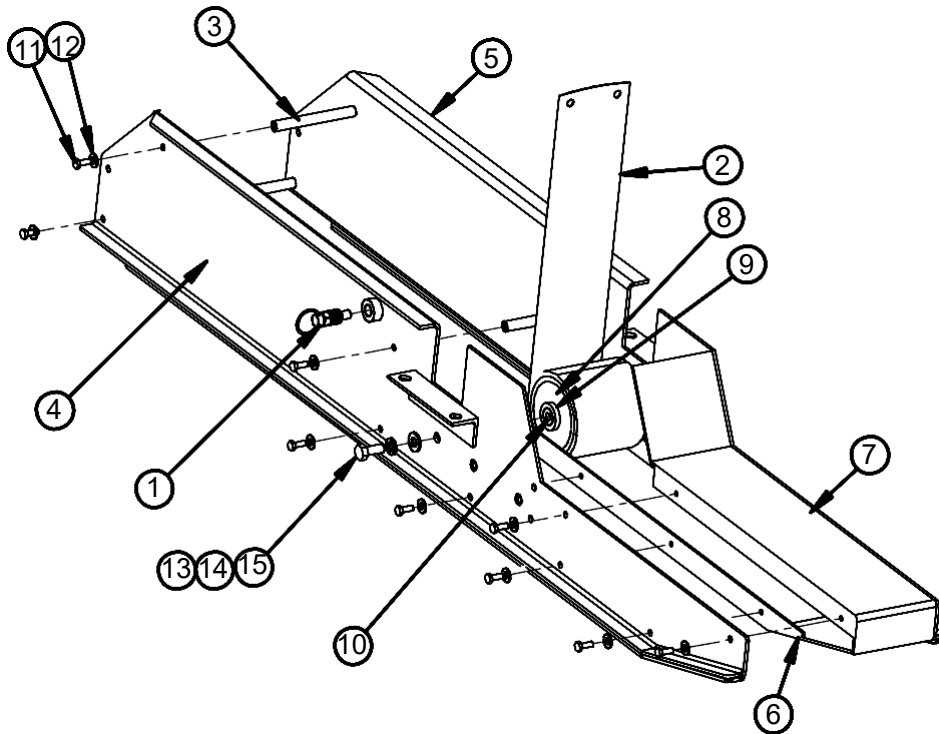

ITEM	PART NO.	DESCRIPTION	Q'TY
1	5000598	PLUNGER-RETRACTABLE	1
2	5000046	SPRING – CONSTANT FORCE 3" WIDE	1
3	5000227	MACH-SPACER, HEAD PLATES	3
4	5000566	FAB/WELD – HEAD FRAME WELDMENT, L	1
5	5000580	FAB/WELD – HEAD FRAME WELDMENT, R	1
6	5000573	FAB – FILL-IN PLATE, 2"	1
7	5000572	FAB – COVER PLATE, 2"	1
8	5000202	MACH – DRUM, CONST FORCE SPRING	1
9	5000930	WASHER, 1-3/8" OD x 5/8" ID, SS	4
10	5000571	MACH -SHAFT, DRUM, 5/8" OD x 3.375"	1
11	055293-025	SCREW – HH #10-32 x 1/2" ZINC	18
12	055029-011	WASHER – FLAT #10 CRS ZINC	18
13	055293-056	SCREW – HH 5/16"-18 x 3/4" ZINC	2
14	5000339	WASHER – 5/16" SPLIT, ZINC	2
15	5000333	WASHER – FLAT 5/16", ZINC	2



## Upper Tape Head Seat to Column Assembly

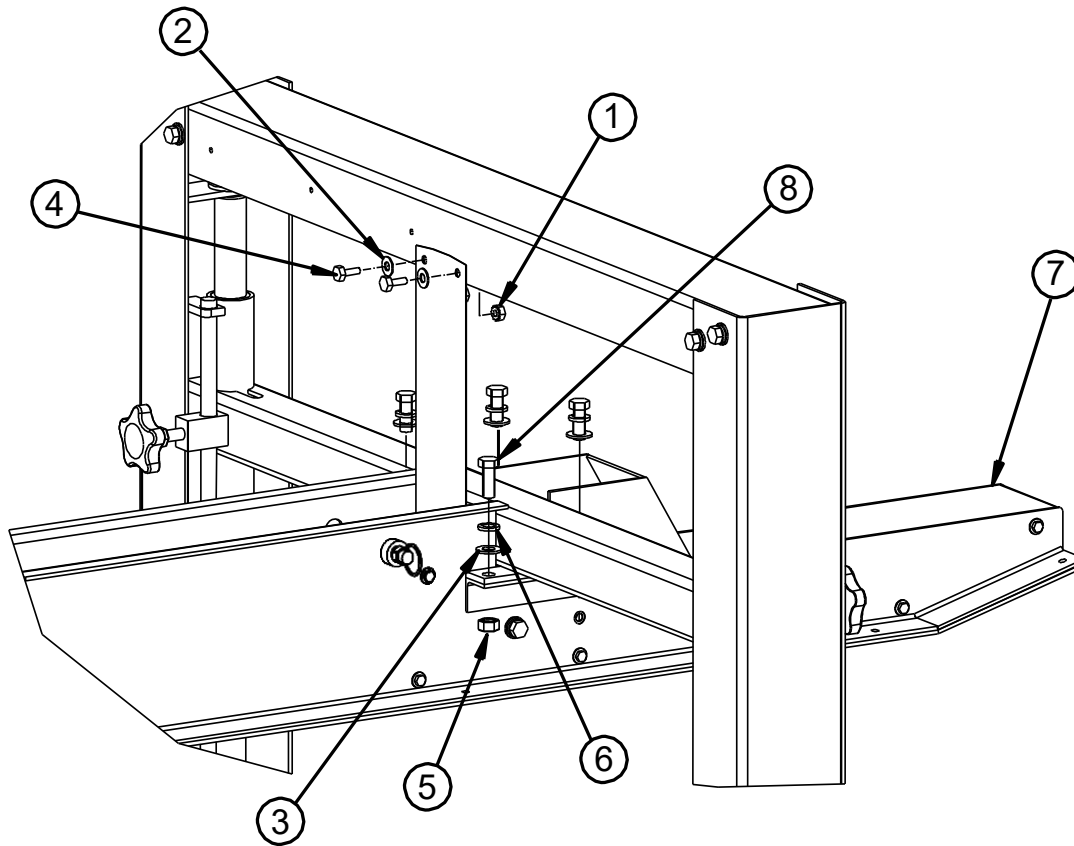

ITEM	PART NO.	DESCRIPTION	Q'TY
1	054982-006	NUT – KEP ¼" -20 NC ZINC	2
2	055029-018	WASHER – FLAT ¼" SST	2
3	055029-022	WASHER – FLAT ¾" ZINC	4
4	055293-038	SCREW – HH ¼" -20 × 5/8" SST	2
5	053307-062	NUT – HEX ¾" -16 NI	4
6	055310-042	WASHER – SPLIT ¾" NI	4
7	5000405	ASSEMBLY – HEAD, SB-2 HD	1
8	5000791	SCREW – HH 3/8" -16 × 1" NI	4



## Side Belt Frame, Idler Pulley, and Tension Brackets

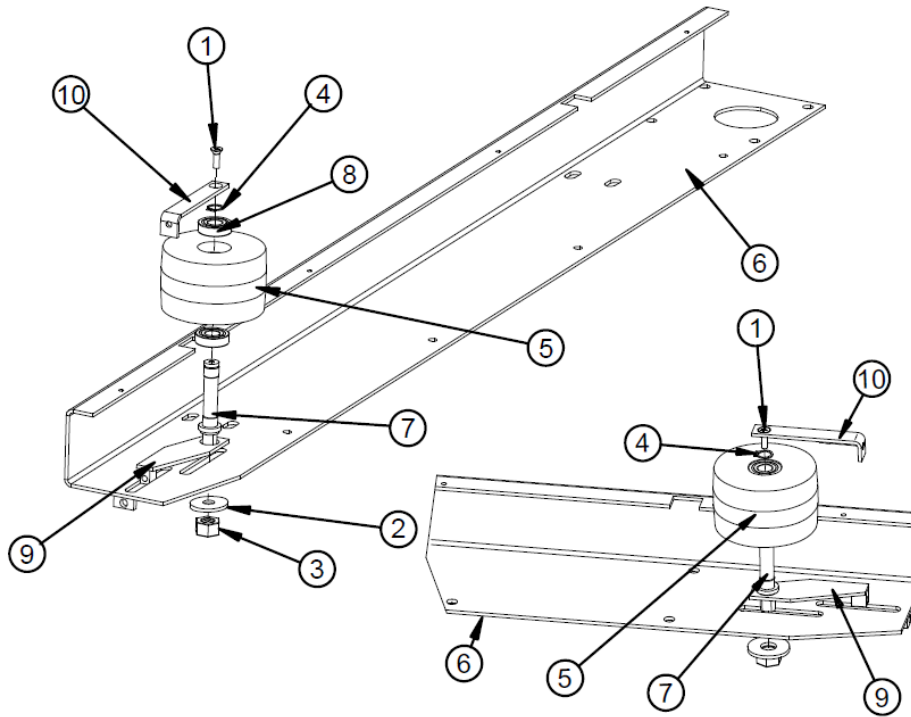

**NOTE:** Top illustration shows left-hand assembly; lower inset shows right-hand assembly.

ITEM	PART NO.	DESCRIPTION	Q'TY
1	055020-088	SCREW – FH, #10-32 × ½" SST, PH (82)	1
2	055029-025	WASHER – FLAT ½" CS ZINC	1
3	055307-069	NUT – HEX ½"-13 ZINC	1
4	5000340	RING, RETAINING, ¾" SHAFT	1
5	5000419	MACH – SB IDLER ROLLER PULLEY	1
6-L	5000527	FAB – DRIVE FRAME, LEFT	1
6-R	5000528	FAB – DRIVE FRAME, RIGHT	1
7	5000533	MACH – SB IDLER ROLLER SHAFT	1
8	5000604	BEARING – SB IDLER ROLLER	2
9-L	5000702	FAB – BELT TENSIONING BRACKET, BOTTOM, LEFT	1
9-R	5000695	FAB – BELT TENSIONING BRACKET, BOTTOM, RIGHT	1
10	5000928	FAB – BELT TRACKING BRACKET, TOP	1



## Side Belt Motor, Motor Pulley, and Attaching Hardware

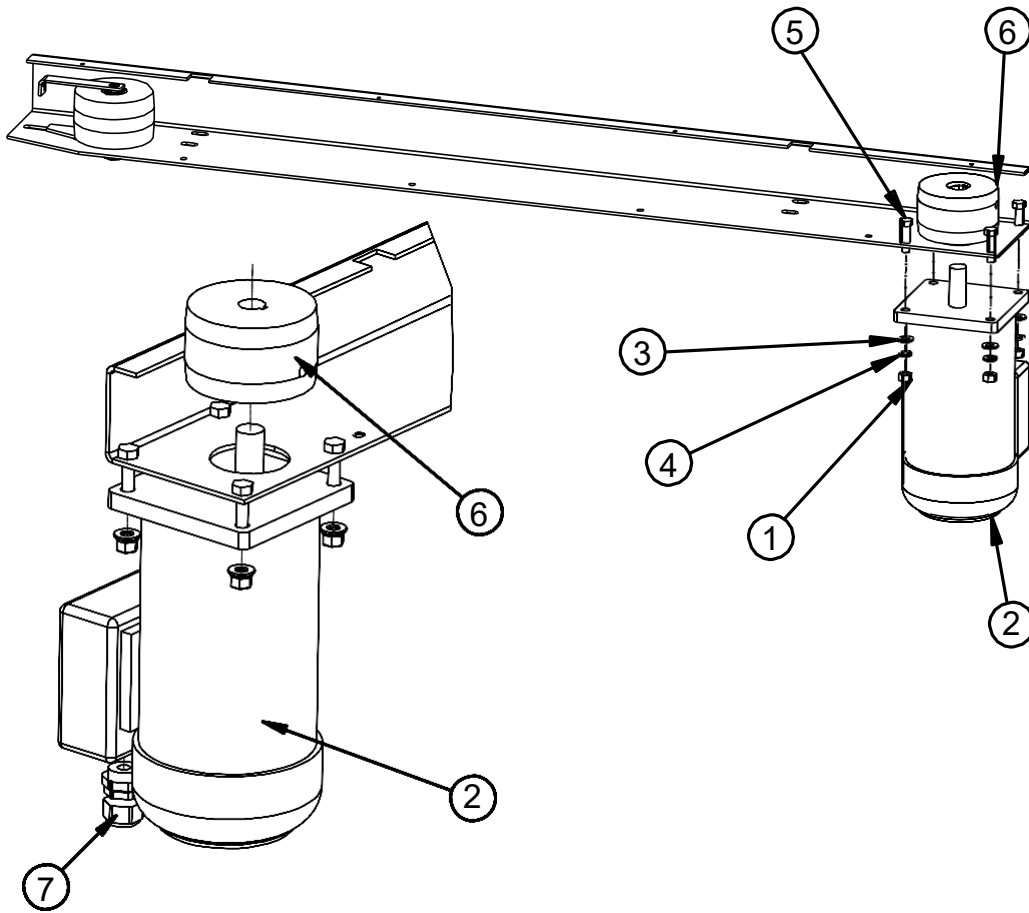

**NOTE:** Top illustration shows left-hand assembly; lower inset shows right-hand assembly.

ITEM	PART NO.	DESCRIPTION	Q'TY
1	055307-055	NUT – HEX, $\frac{5}{16}$ "-18 ZINC	4
2	5000311	SIDE BELT GEAR MOTOR	1
3	5000333	WASHER – FLAT $\frac{5}{16}$ ", ZINC	4
4	5000339	WASHER – $\frac{5}{16}$ " SPLIT, ZINC	4
5	5000803	SCREW – HH $\frac{5}{16}$ "-18 $\times$ 1- $\frac{1}{4}$ " SST	4
6	5000807	ASSEMBLY – SB DRIVE ROLLER	1
7	1602253	STRAIN RELIEF	1



## Side Belt Guide Strips and Attaching Hardware

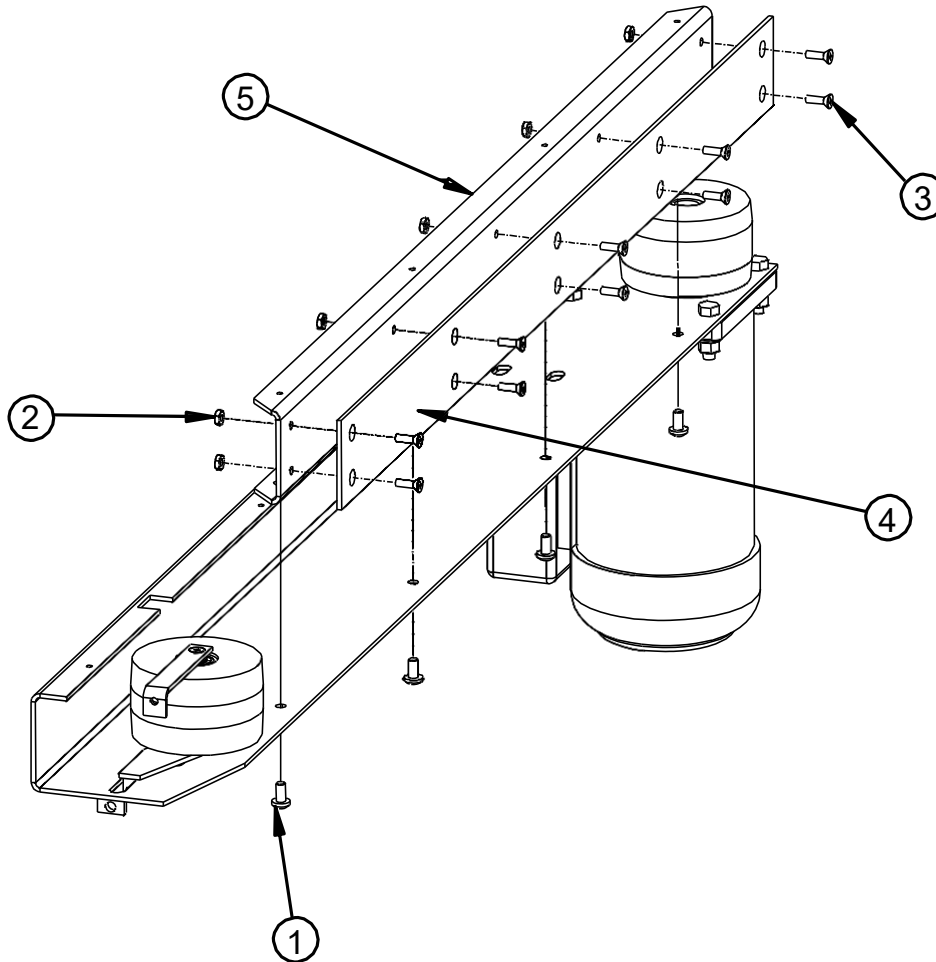

**NOTE:** Above illustration shows left-hand assembly; right-hand assembly is the mirror image.

ITEM	PART NO.	DESCRIPTION	Q'TY
1	054979-141	SCREW – PH ¼”-20 × ½” NI PH EXT	4
2	054982-005	NUT – KEP, #10-32 NC ZINC	10
3	055020-088	SCREW – FH, #10-32 × ½”, SST, PH(82)	10
4	5000540	FAB – BELT STRIP	1
5	5000541	FAB – STRIP BRACKET	1



## Side Belt Belts, Tensioning & Frame Attaching Screws

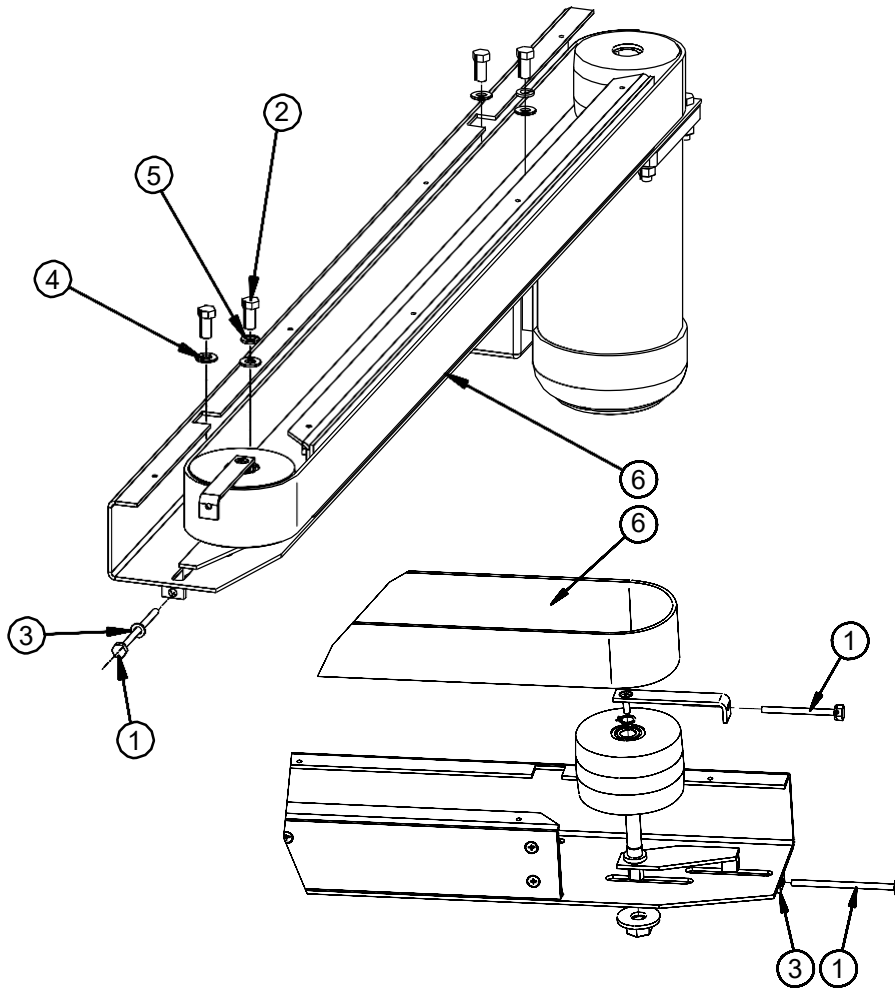

**NOTE:** Top illustration shows left-hand assembly; lower inset shows right-hand assembly.

ITEM	PART NO.	DESCRIPTION	Q'TY
1	055293-049	SCREW – HH ¼" -20 × 3-½" TAP BOLT	1
2	055293-056	SCREW – HH 5/16" -18 × ¾" ZINC	4
3	100694-001	WASHER – FLAT, M6, DIN 125 A	1
4	5000333	WASHER – FLAT 5/16", ZINC	4
5	5000339	WASHER – 5/16" SPLIT, ZINC	2
6	5000853	BELT (SET) – SIDE EZ SB	1



## Side Belt Cover & Cover Attaching Screws

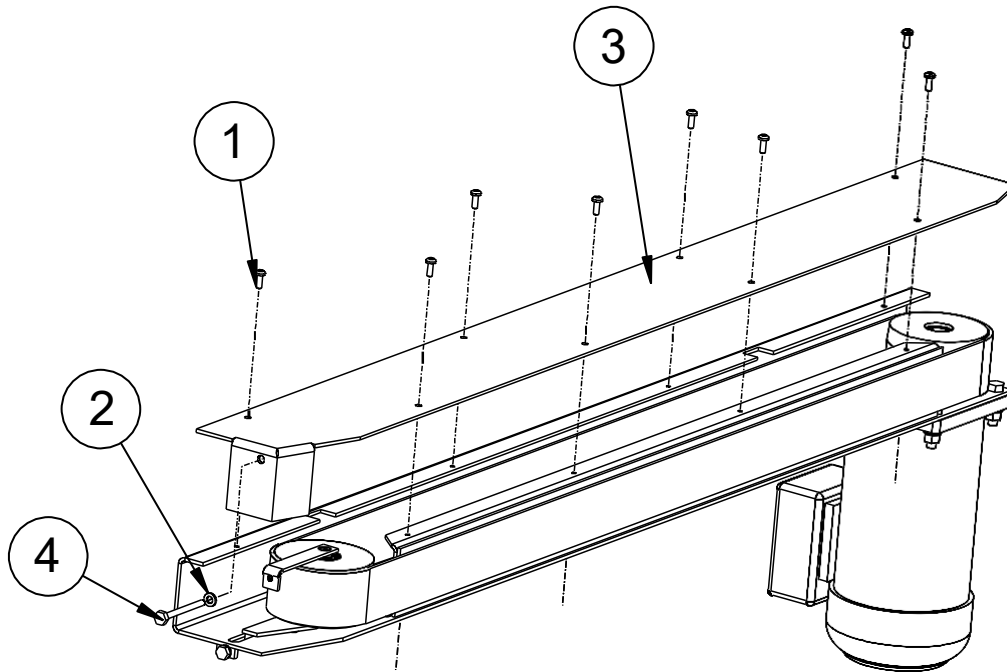

**NOTE:** Above illustration shows left-hand assembly; right-hand assembly is the mirror image.

ITEM	PART NO.	DESCRIPTION	Q'TY
1	059479-123	SCREW – PH #10-32 × ½ PH SS SEMS – IN	8
2	100694-001	SCREW – HH 5/16" -18 × ¾" ZINC	4
3-L	5000529	FAB – DRIVE COVER, LEFT	1
3-R	5000530	FAB – DRIVE COVER, RIGHT	1
4	5000804	SCREW – HH ¼" -20 × 3-½" TAP BOLT	4



**Tape Head** — Refer to Tape Head User Guide

Refer to the parts illustrations and listings in the Tape Head User Guide provided with the tape head for identification and part numbers of tape head parts.