



CE-325

**Bottle Sleeve Steam Heat Tunnel
Operation Manual**



866-888-6327

sales@clevelandequipment.com

3889 E Raines Rd

Memphis, TN 38118

www.clevelandequipment.com



Table of Contents

1.	Foreword	3
2.	Brief Introduction of the Function.....	3
3.	Specification	4
4.	Panel Function Description	5
5.	Instructions.....	6
6.	Circuit Diagram.....	7
7.	Parts Diagram and Name.....	8
8.	Common Malfunction and Method	11
9.	Shrink Film Temperature & Time Control Values	11
10.	Maintenance	12
11.	Accessories list	13



1. Foreword

The CE-325 steam label shrink machine is mainly used in heat shrink labels of cosmetic, dairy products, beverage, and other products after labeling. This machine has high thermal efficiency, shrink chamber temperature uniformity, stable and reliable, accurate temperature control. Please read the instructions carefully before installation and use, to understand the basic performance of the machine, structure, operation and maintenance methods.

Special Note:

1. **All the parameters and content for the specification, the company reserves the right to interpret;**
2. **The company reserves the right that product technical changes without prior notice.**

2. Function

Label shrink packaging currently on the market is one of the commonly used packing method, it is to use the product label film wrapped on the outside of the product, after steam heating, shrink label film wrapped products, it shows that the appearance of goods, improve the product exhibition, increase the sense of beauty and value. Suitable for cosmetic, dairy products, beverages and other products labeled.

This machine is high energy efficiency, low energy supply to complete the perfect contraction. It is easy to adjust and use. Any bottle type can be simply adjusted to achieve the effect of smooth appearance and aesthetic shrink.



3. Specification

Max. Packing Size	100mm	Shrink Speed	5000-7500 Bottles/h
Voltage	220V 50Hz	Steam Pressure	0.1MPa
Power	150W	Steam Use Quantity	8Kg/h
Weight	68Kg	Shrink Temp.	75-85°C
Height of Shrink	290mm	Machine size(L*W*H)	1760*400*1250

Remark: We can customize non-standard machines according to customer requirements.

Matched Steam Source LDR24-0.45Z, Steam Generator Specification:

Power	12/24kW
Voltage	380V
Pressure	0.45MPa
Volume	27L
Steam production	24Kg/h
Machine Weight	85kg

Remark: The steam generator can be configured according to customer's requirements



4. Panel Function Description

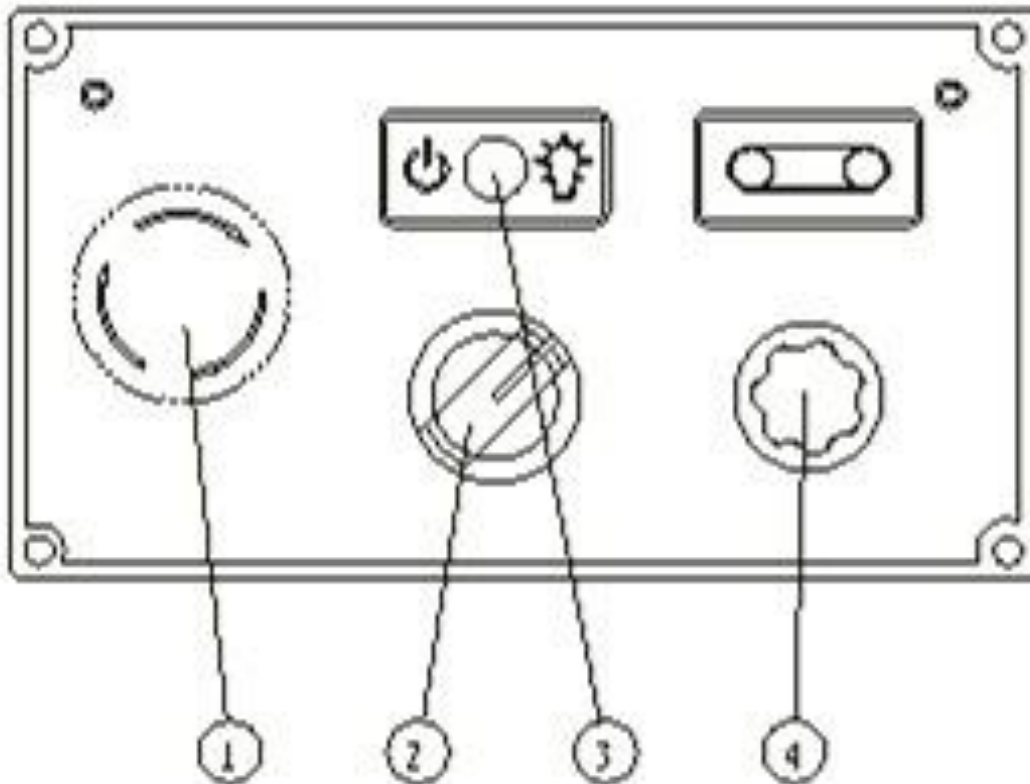

- ① Emergency Stop: control the machine stop instantly;
- ② Power switch: control the power turn on and off;
- ③ Power indicator: show the state of the power;
- ④ Conveyor switch: control the conveyor speed.



5. Instructions

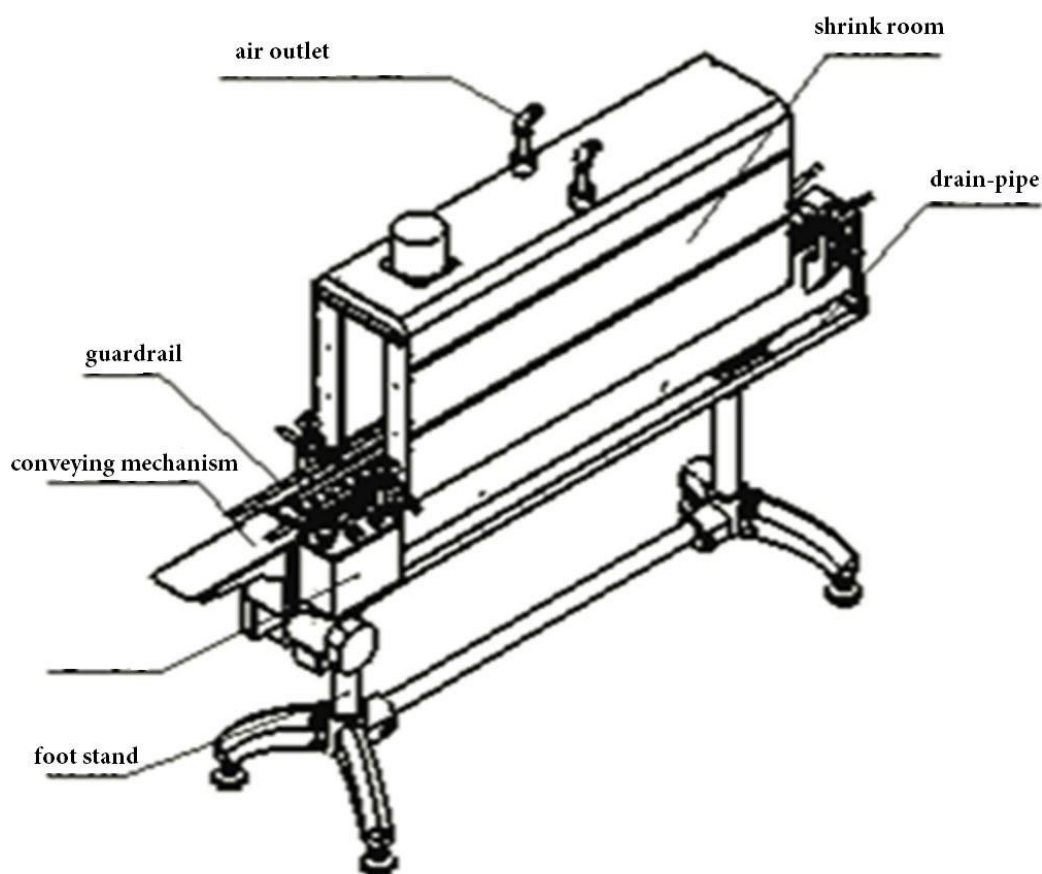

1. Place the machine on flat ground, remove the outer packaging.
2. Push the machine to the installation location, according to figure 1 install the machine, then access the regulation power and steam source, meanwhile, check each part of machine whether have any loose, dislocation and damage caused by transit.
3. In order to ensure the personal safety of the operator, the machine must be grounded according to regulations before use, and to ensure good contact, according to the signs on the machine of power supply voltage (don't make mistakes).
4. If everything is normal, the conveyor switch adjusts to playing the left-most position, turn the power switch on the control box, power indicator light. When the machine starts running, observe whether the movement of the transport mechanism is normal. Conveyor speed can be adjusted to the appropriate speed according to need.
5. Tunnel adjustment: Adjust conveyor and shrink room inside guard lever position so that both sides of the lever from the bottle 1 ~ 2mm, to ensure that bottles can smoothly through the tunnel.



6. Circuit Diagram

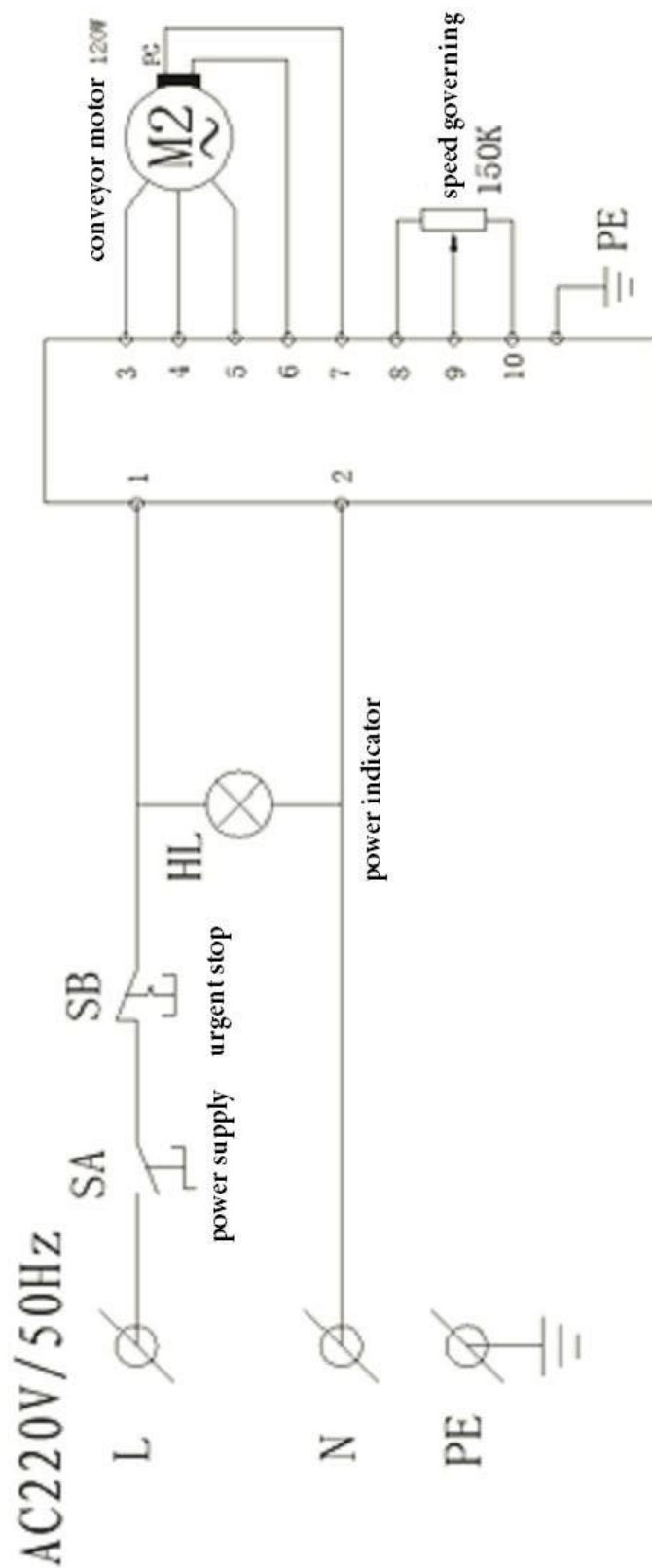



7. Parts List

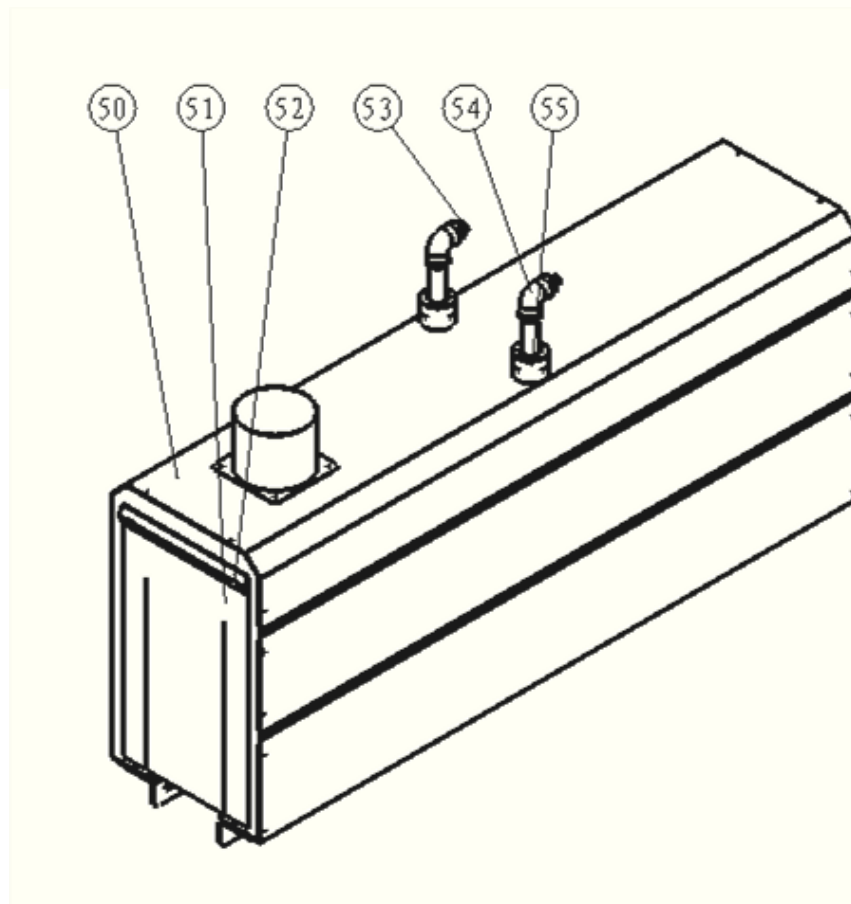
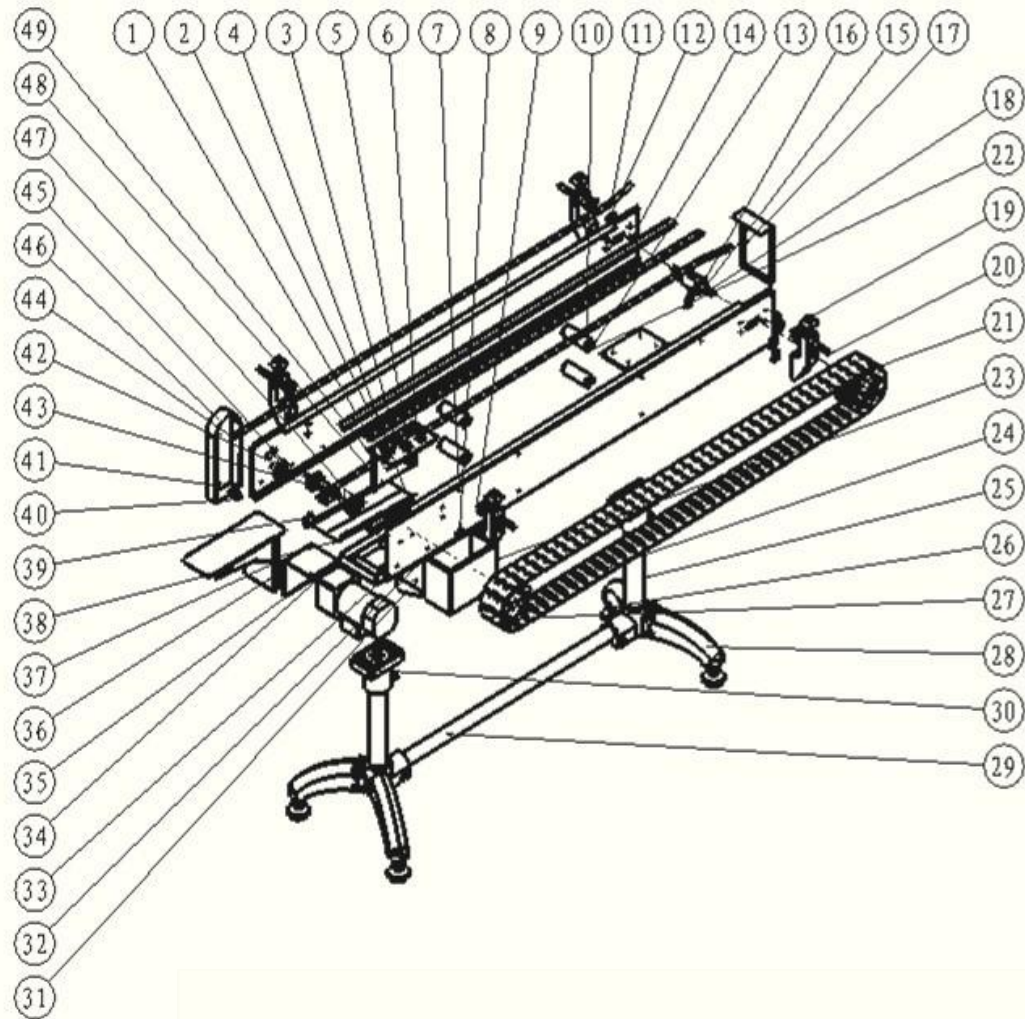



No.	Name of parts	Quantity	type and specification	Remark
1	Chain plate	2		
2	Urgent switch	1		
3	Little indicator	1	Red, $\Phi 9.5$	
4	Supporting frame backplane	2		
5	Change-over switch	1	$\Phi 22$	
6	Speed control knob	1	$\Phi 26$	
7	Left side conveying plate	1		
8	Sink hanging board	4		
9	Monorail joint	8		
10	Deep groove ball bearing	8	6001	
11	Stop level I	2		
12	Article passive wheel adjustment	2		
13	Loop wheel spindle	4		
14	Right side conveying plate	1		
15	Passive sprocket core tube	1		
16	Deep groove ball bearing	2	6002	
17	Conveyor cap	1		
18	Passive wheel adjustment shaft	1		
19	S2 stand	4		
20	pin roll	4		
21	driving wheel	1		
22	Loop wheel	4		
23	electrical box component I	1		
24	Conveyor chain piece	82		
25	Foot stool support bar	2		
26	(LZB-50.9)foot margin	4		
27	Passive wheel	1		
28	(LZB-50.9) foot stool	2		
29	Foot stool horizontal support bar	1		
30	(LZB-50.9)joint	2		
31	Junction box bracket	1		
32	electrical box component II	1		
33	Sink	1		



34	Motor	1	120YT01	
35	Motor block	2		
36	Discharging plate	1		
37	Conveyor motor cabinet	1		
38	Manger	1		
39	Motor chain wheel	1		
40	Shield positioning column	2		
41	Chain wheel shield	1		
42	Driving wheel spindle	1		
43	Bearing pedestal	1		
44	Guide bar plug	4		
45	Driving chain gear	1		
46	Chain wheel shield II	1		
47	Driving chain gear bearing	1		
48	Electrical mounting plate	1		
49	Electrical panel	1		
50	Shrink room	1		
51	Teflon cloth	2		
52	Teflon cloth layering	2		
53	Straight pipe joints	2		
54	Pipe joint	2		
55	Locking ring	2		
	Steam tube	2		



8. Common Malfunction and Method

	CASE	CAUSE	METHOD
1	Label is wrinkly and unflat	Steam pressure is too low	Increase pressure
	after shrinking	Steam valves are opened improperly	Re-arrange
		The conveyor speed is too high	Slow down speed
2	Conveyor runs unsmoothly	Conveyor belt is loose	Tighten it
3	Label isn't in right position	Distance of two brushes are too far	Re-adjust
4	Machine stops suddenly	Electricity supply loose of	Check electricity
		Fuse pipe broken	Exchange

9. Shrink Film Temperature & Time Control Values (Only for refer)

Term Film	Name	Thickness (mm)	Heating time (s)	Shrink Temp. (°C)
Polyvinyl Chloride	PVC	0.02-0.06	5-10	110-130
Polypropylene	PP	0.02-0.04	6-12	130-170
Polyethylene	PE	0.06-0.20	10-60	150-180
	POF	0.03-0.10	8-16	130-170



10.Maintenance

- (1) Keep the body clean, and electrical parts should keep dry and ventilated.
- (2) Clean up the water in the water pond, dry equipment with dry cloth.
- (3) Do not put any other stuff on conveyor belt in case of damaging belt and shrink tunnel.
- (4) Before servicing the machine, you must turn off the power; when the repair, it should be maintained by the professionals or notify the company to help.
- (5) The machine warranty for one year, namely machine within a year due to quality problems of malfunction, the company provides free maintenance. Due to improper operation or other natural disasters and force majeure caused by fault, the company charges part of the maintenance costs, replacement parts cost is charged according to its value.
- (6) More than the warranty period, the company continues to maintain work, but need to take into consideration the fee.
- (7) When user self-repair, the company provides sales of spare parts service.
- (8) Long downtime, you must turn off the power switch and gas source.
- (9) Before going to work every day to check whether the screws of the moving parts is loose.

Note: When commissioning the machine, any part of the body can't be in the mobile position of the machine, so as to avoid burns or bumps!

(10) Check-repair and feedback report

Thanks a lot for purchasing our DZBS1135 steam-type label shrink machine. For your right choose, you possess reliable、high-efficient packaging machine. We hope to establish long-term cooperation with you, and we will be appreciated very much if you would like to send us the feedback report or your kind suggestion.



11. Accessories list

1	Operational Instruction	DZBS1135 Operational Instruction	pcs	1
2	Certificate	DZBS1135 Factory Quality Certificate	pcs	1
3	Allen wrench	complete set(M3\M4\M5\M6\M8\M10)	pcs	1
4	Screwdriver	Slotted screwdriver (5 inch)(6*100) (large)	pcs	1
5	Screwdriver	Cross (4 inches) (6*100) (large)	pcs	1
6	Fuse pipe	$\phi 5*20/6A$	pcs	2
7	Open-end wrench	8-10	pcs	1
8	Open-end wrench	12-14	pcs	1
9	Tool bag	White	pcs	1
10	Common wooden case	180*45*125	set	1
11	PC board for speed control	AC 6 μ F	pcs	1
12	Open-end wrench	19-22	pcs	1