



# Cleveland Equipment

## PBC6000 PINCH BAG CLOSER

### INSTALLATION, OPERATION, AND MAINTENANCE MANUAL



866-888-6327

[sales@clevelandequipment.com](mailto:sales@clevelandequipment.com)

4403 Delp Street

Memphis, TN 38118

[www.clevelandequipment.com](http://www.clevelandequipment.com)



## Contents

1.	Preface .....	3	5.2.5.1.	Removing The Heater Elements .....	62
1.1.	Application Of Manual .....	3	5.2.5.2.	Replacing The Heater Elements.....	64
1.2.	Safety Statement .....	3	5.2.5.3.	Testing And The Autotune Function .....	64
1.3.	Warnings, Cautions, And Notes .....	4	5.2.6.	Ready Light.....	65
1.4.	Acronyms.....	6	5.2.8.	Flow Switch .....	66
2.	Introduction.....	7	5.2.9.	Drive Motor & Bearings.....	66
2.1.	Common Applications .....	7	6.	Maintenance.....	67
2.2.	Machine Options.....	8	6.1.	Daily Maintenance .....	67
2.3.	Major Components .....	9	6.2.	Monthly Maintenance.....	68
2.4.	Performance Characteristics .....	13	6.2.1.2.	Height Adjustment System.....	69
2.4.1.	System Speed Ranges.....	13	6.2.2.	Pneumatics.....	69
2.4.3.	Miscellaneous.....	13	6.2.2.2.	Airflow Valves And Gauge.....	70
2.5.	System Characteristics .....	14	6.2.3.2.	Proximity Sensors.....	71
2.5.3.	System Dimensions .....	15	6.2.3.3.	Airflow Sensor .....	71
3.	Installation .....	16	6.2.4.	Compression Belts .....	71
3.1.	Recommended Work Area Layout.....	16	6.2.4.1.	Compression Belt Upkeep .....	71
3.2.	Site And System Preparation.....	16	6.2.5.	Hot Air (Heater) Manifold .....	72
3.3.	Unpacking Procedure .....	19	6.2.6.	Drive Motor And Gears.....	72
3.4.	On Line Preparation .....	21	7.	Quality Control Guide .....	73
3.4.1.	Safety Guidelines.....	21	7.1.	General Conditions For A Good Seal .....	73
3.5.	Electrical System .....	22	7.1.1.	Correct Adhesive Temperature .....	73
3.6.	Pneumatics System .....	23	7.1.2.	Bag Surface Preparation .....	73
3.7.	Leveling And Centering .....	24	7.1.3.	Proper Bag Presentation .....	73
3.7.1.	Leveling.....	24	7.2.	Typical Bag Closures .....	74
3.7.2.	Centering .....	24	7.2.1.	Proper Closures .....	74
3.8.	Speed Checks And Synchronization.....	26	8.	Troubleshooting .....	77
3.9.	Folder.....	27	8.1.	Questions Concerning Bag Seals .....	77
3.10.	Compression Belts And Rollers.....	27	8.2.	General Closer Problems.....	78
3.11.	Setting The Temperature.....	28	9.	Recommended Spare Parts List .....	79
3.11.2.	Set Point Display And Changes.....	30			
4.1.	Operating The Machine .....	31			
4.2.	Process Description.....	31			
4.3.	Startup Procedure.....	32			
4.4.	Trial Run And Bag Closure Test .....	34			
4.5.	Shutdown Procedure .....	34			
5.	Adjustments And Part Replacements .....	35			
5.1.	Adjustment Procedures .....	35			
5.1.1.2.	Carry Through Belt Tension .....	37			
5.1.3.	Creaser Wheel.....	44			
5.1.3.1.	Creaser Roller Wheel (Die) Horizontal Adjustment .....	45			
5.1.3.2.	Creaser Roller Wheel (Die) Vertical Adjustment .....	45			
5.1.3.3.	Swing Channel Creaser Blade Height.....	46			
5.1.3.5.	Creaser Blade Pressure .....	48			
5.1.4.1.	Folder And Bottom Folder Guide .....	49			
5.1.4.2.	Heater Manifold Guide .....	50			
5.1.5.	Temperature Controller.....	52			
5.1.5.1.	Temperature Adjustment .....	53			
5.2.2.	Compression Rollers.....	56			
5.2.3.	Take-Up Rollers.....	57			
5.2.4.	Drive Sprockets And Tension Pulleys .....	59			
5.2.4.2.	Carry Through Belt Drive Pulleys.....	60			
5.2.4.3.	Compression Belt Drive Sprockets .....	62			
5.2.5.	Hot Air (Heater) Manifold .....	62			



## 1. PREFACE

**Note: Installers and operators of this equipment should read this entire document**



**before attempting to handle or operate the machine. Locate all additional manuals supplied with the machine and refer to them as necessary.**

### 1.1. Application of Manual

This service manual is written as a guide to the proper installation, operation, service, and maintenance of the following PBC6000 Pinch Bag Closer (also referred to as “the machine”).

Basic knowledge of the system is essential to ensure satisfactory service. This manual will provide the knowledge so that, with proper maintenance, the machine will provide years of trouble-free performance to its users.

### 1.2. Safety Statement

The PBC6000 Pinch Bag Closer is driven by strong gearmotors, contains moving parts, has pinch points, and machine surfaces. Therefore, a certain amount of technical training and familiarity with this type of equipment is required to operate and maintain the system. Installers and operators of the machine should wear proper eye, foot, and hand protection. Turn off and lock out air and power sources when cleaning or performing maintenance. Once the air source has been locked out, existing air pressure in the system will be released.

***is not responsible for damage or injuries caused by misuse of the equipment, for careless operation or if it is used to seal materials for which it was never designed.*** Installers of this machine should always wear eye and foot protection and gloves when working around the machine surfaces. Operators should always wear proper eye protection when operating this machine and not wear loose clothing or jewelry. Long hair should be pulled back and tied to avoid getting caught in the infeed or conveyor belts.



## 1.3. Warnings, Cautions, and Notes

Applicable warnings, cautions, and notes have been placed throughout this manual. Each user of the machine must be familiar with each of these. It is imperative that all personnel involved in the operation or maintenance of this system follow the basic safety precautions outlined below.

The use of icons and colored text will highlight each to the user.



**WARNING: THESE REFER TO ANY ACTIONS OR SITUATIONS THAT COULD INJURE, DISABLE, OR EVEN KILL THE OPERATOR OR TECHNICIAN!**



**CAUTION: THESE REFER TO ANY ACTIONS OR SITUATIONS THAT COULD DAMAGE OR DESTROY THE MACHINE!**



**Note:** These provide important and/or useful information.

### 1.3.1. GENERAL CAUTIONS AND WARNINGS



**ALWAYS USE *GENUINE* PARTS. OUR PARTS ARE SPECIFICALLY DESIGNED FOR EQUIPMENT TO PROVIDE OPTIMUM PERFORMANCE AND SAFETY. USE OF NON-PARTS WILL VOID THE PRODUCT WARRANTY.**



**READ AND FOLLOW THE MANUALS FOR THE DEVICES USED IN THE PBC 6000 SYSTEM. THE ACCOMPANYING MANUALS ARE IN THE ELECTRICAL ENCLOSURE. THESE MANUALS WILL PROVIDE THE APPROPRIATE INSTRUCTIONS FOR OPERATING AND MAINTAINING INDIVIDUAL COMPONENTS.**



**EMPLOYEES SHALL RECEIVE TRAINING BY THE EMPLOYER ON PROPER EQUIPMENT OPERATION AND SHUTDOWN PROCEDURES FOR THIS MACHINE.**



**WHEN USED IN A DUSTY ENVIRONMENT, NEMA-12 (IP54) ELECTRICAL EQUIPMENT MUST BE USED.**



**LET THE MACHINE DO THE WORK. DO NOT PULL THE BAG THROUGH THE MACHINE.**



**FREQUENTLY CLEAN THE MACHINE TO PREVENT THE ACCUMULATION OF DUST, BAG, AND GLUE MATERIALS, WHICH MAY CAUSE MALFUNCTIONS AND/OR POOR BAG SEALS.**



**FREQUENTLY REMOVE EXCESS GLUE FROM THE COMPRESSION BELTS USING A DULL-EDGED SCRAPER. BE CAREFUL NOT TO CUT OR GOUGE THE BELT SURFACE.**



**WARNING: GRAB, PINCH, AND CRUSH HAZARDS!**

THIS MACHINE USES POWERFUL MOTORS THAT DRIVE BELTS, CHAINS, AND PULLEYS. EXTREME CAUTION SHOULD BE USED WHEN OPERATING OR SERVICING THIS MACHINE. NEVER OPERATE THE MACHINE WITHOUT THE GUARDS AND COVERS IN PLACE. ALWAYS TURN OFF THE MACHINE AT THE POWER DISCONNECT SWITCH AND REMOVE ALL POWER TO THE ELECTRICAL BOX BEFORE SERVICING OR ADJUSTING THE MACHINE. NEVER WEAR LOOSE OR BAGGY CLOTHING WHILE OPERATING THIS MACHINE. ALWAYS TIE BACK LONG HAIR WHEN OPERATING THIS MACHINE. FAILURE TO OBSERVE THIS WARNING COULD RESULT IN SEVERE INJURY.



**WARNING: SHOCK HAZARD!** THIS MACHINE USES HIGH VOLTAGE ELECTRICITY. ONLY LICENSED ELECTRICIANS SHOULD SERVICE THE ELECTRICAL COMPONENTS OF THIS MACHINE. NEVER OPERATE THIS MACHINE WITH THE ELECTRICAL BOX DOOR OPEN. NEVER ATTEMPT TO MODIFY THE ELECTRONICS OF THIS MACHINE. FAILURE TO OBSERVE THIS WARNING COULD RESULT IN SEVERE INJURY OR DEATH.



**WARNING: BURN HAZARD!**

THIS MACHINE USES A HIGH-TEMPERATURE, OPEN COIL HEATING ELEMENT; THE WASH-DOWN APPLICATION USES TWO HIGH-TEMPERATURE HEATING ELEMENTS. THE HEATERS ARE EXTREMELY HOT! NEVER OPERATE THIS MACHINE WITHOUT THE GUARDS IN PLACE. ALLOW ENOUGH TIME FOR THE HEATER TO COOL DOWN BEFORE PERFORMING ANY MAINTENANCE. FAILURE TO OBSERVE THIS WARNING COULD RESULT IN SEVERE INJURY.



**WARNING: CRUSH HAZARD!**

THIS MACHINE WEIGHS APPROXIMATELY 795 LBS (360.61 KGS), AND IT MEASURES 74" X 56" X 71" (1880MM X 1422MM X 1803MM) IN SIZE. MAKE SURE THAT THIS MACHINE IS SITTING ON A SMOOTH, HARD, LEVEL SURFACE. NEVER ATTEMPT TO TILT THE MACHINE. FAILURE TO OBSERVE THIS WARNING COULD RESULT IN SEVERE INJURY OR DEATH.



**WARNING: EXPLOSION HAZARD!**

NEVER OPERATE THIS MACHINE IN AN AREA WHERE EXPLOSIVE MATERIALS ARE PRESENT (E.G. EXPLOSIVE GASES, POWDERS, VAPORS, OR LIQUIDS). DOING SO COULD RESULT IN SEVERE INJURY OR DEATH.



**WARNING: CONTINUOUS ENERGY HAZARD!**

REPLACEMENT OF THE QUICK RELEASE AIR COUPLING (P/N P4945) MAY VIOLATE OSHA SAFETY REGULATION #1910 FOR CONTINUOUS HAZARDOUS ENERGY. FAILURE TO OBSERVE THIS WARNING COULD RESULT IN SERIOUS INJURY.



## 1.4. Acronyms

List of commonly used acronyms that may be used throughout this manual and can be used as a quick reference as needed when using this manual.

<b>AWG</b>	American Wire Gauge
<b>FPM</b>	Feet per minute
<b>ID</b>	Inside dimension
<b>IP</b>	Ingress Protection
<b>MPM</b>	Meters per minute
<b>NEC</b>	National Electrical Code
<b>NEMA</b>	National Electrical Manufacturers' Association
<b>NFPA</b>	National Fire Protection Association
<b>NS</b>	New Standard
<b>OD</b>	Outside dimension (or outside diameter)
<b>PE</b>	Polyethylene
<b>PSI</b>	Pounds per square inch
<b>RPM</b>	Revolutions per minute
<b>SCFM</b>	Standard cubic feet per minute
<b>SCMH</b>	Standard cubic meters per hour



## 2. INTRODUCTION

### 2.1. Common Applications

The PBC6000 is a heavy-duty, production line system that folds and closes pre-glued, multi-wall paper bags with a fold of up to 1¾" (44.45 mm).



**Note: The PBC is also available with the option to fold 2⅝" folds.**

The system is designed for easy opening as a primary safety factor in case of an emergency. This feature also prevents the motor from overload if a bag becomes jammed.

The patented break-away feature provides immediate access to the machine's heating assembly, drive belts, and other moving parts requiring maintenance. The unit is compact and adjustable to allow various bag sizes, conveyor speeds, and heights.

This equipment services the bagging needs of a broad range of products. Common uses include flour, pet food, agricultural seed, animal feeds, feed additives, lawn fertilizers, absorptive materials, industrial and agricultural chemicals, powdered dairy products, and bakery mixes.



## 2.2. Machine Options

This machine is available with the following options:

<b>Option</b> (Customer's machine may include any combination)
Right-to-Left Feed
Standard Length, Manual Infeed
Standard Length, Automated Infeed
extended Length, Automated Infeed
Standard 1-3/4" Folder
Wide 2-3/8" Folder
Reverse Fold, 1-3/4" Folder
Reverse Fold, 2-3/8" Folder
Standard Height Frame
Manual Lift Mechanism Controlled w/Hand Crank on Top of Frame
230 V, 3 Phase, 60 Hz
230 V, 1 Phase, 60 Hz
460 V, 3 Phase, 60 Hz
NEMA 4/4X (Includes NEMA 4 Electronics, Stainless Steel Enclosures, Wash-Down Motors, & Closed Cartridge Heaters)



### 2.3. Major Components

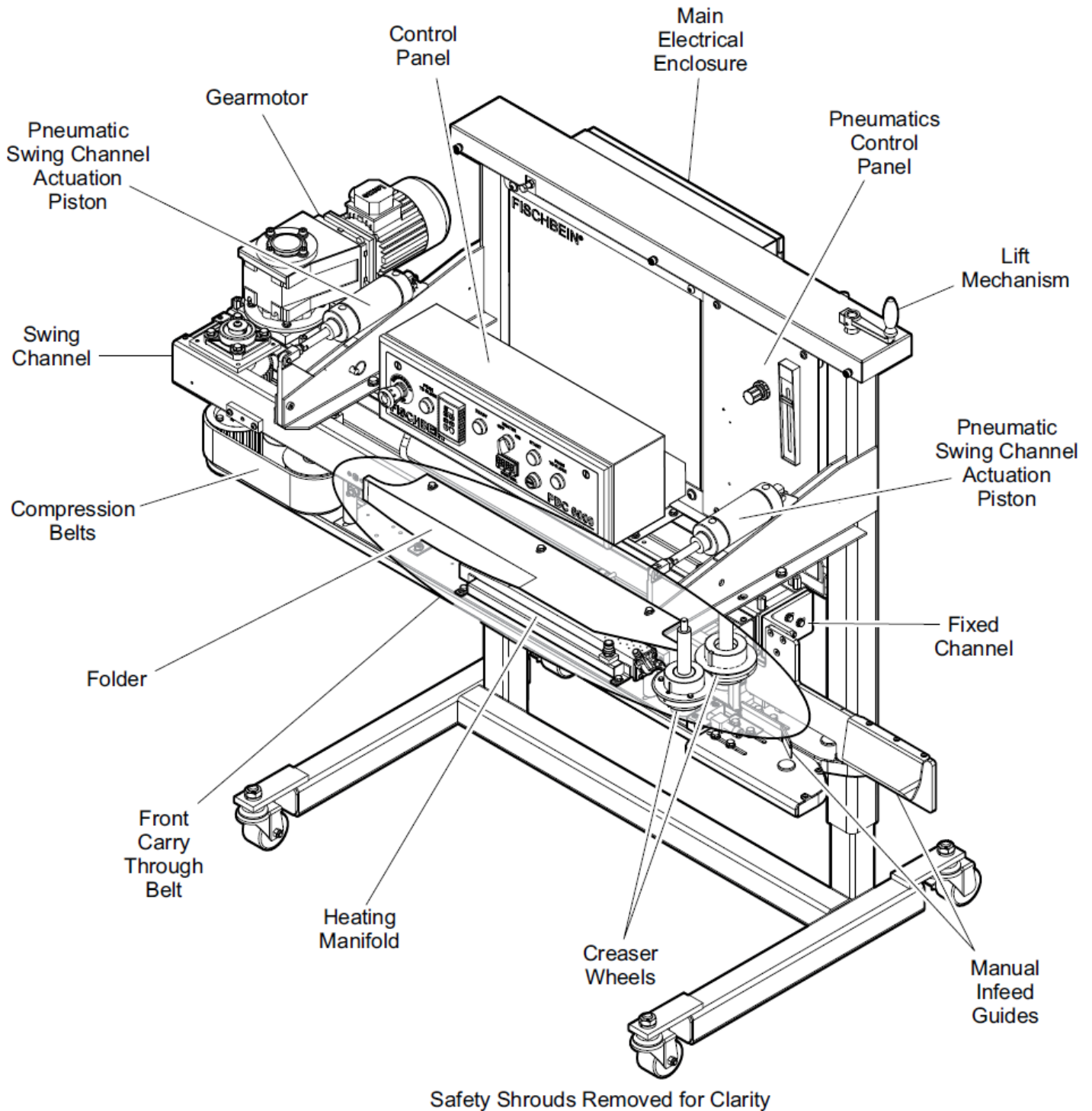

Figure 2-1: PBC6000 Right-to-Left Pinch Bag Closer Major Components - Front View

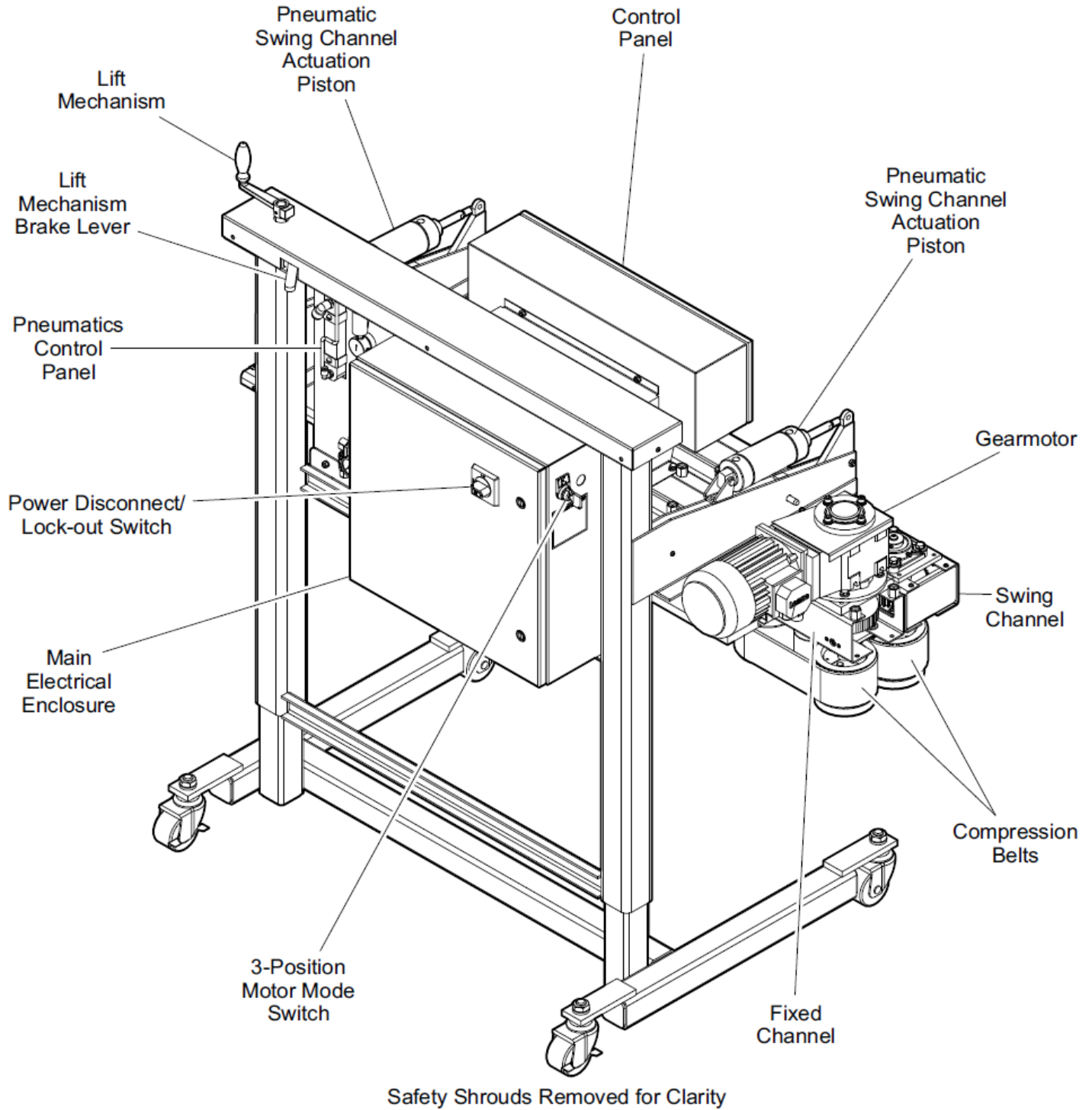

Figure 2-1: PBC6000 Right-to-Left Pinch Bag Closer Major Components - Rear View



### 2.3.1. 3-POSITION MOTOR MODE SWITCH

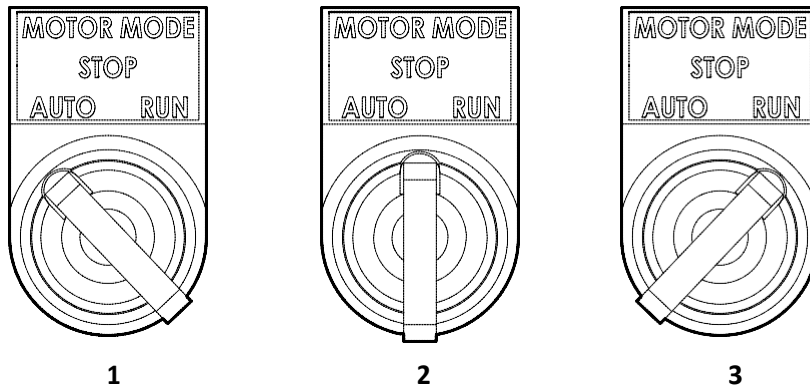

Figure 2-2: Motor Mode Switch

3-Position Motor Mode Switch has three positions:

1. **AUTO** – Use this mode, for normal operation. In this mode, the motor starts when the PUSH TO CLOSE buttons are pressed and remains running as long as the swing channel remains closed.
2. **STOP** – Use this mode for maintenance and troubleshooting. In this mode the motor can be stopped while the swing channel remains closed.
3. **RUN** – Use this mode for maintenance and troubleshooting. In this mode the motor will run with the swing channel open, and it can be tracked and stopped at the desired position for cleaning and inspection.

### 2.3.2. CONTROL PANEL

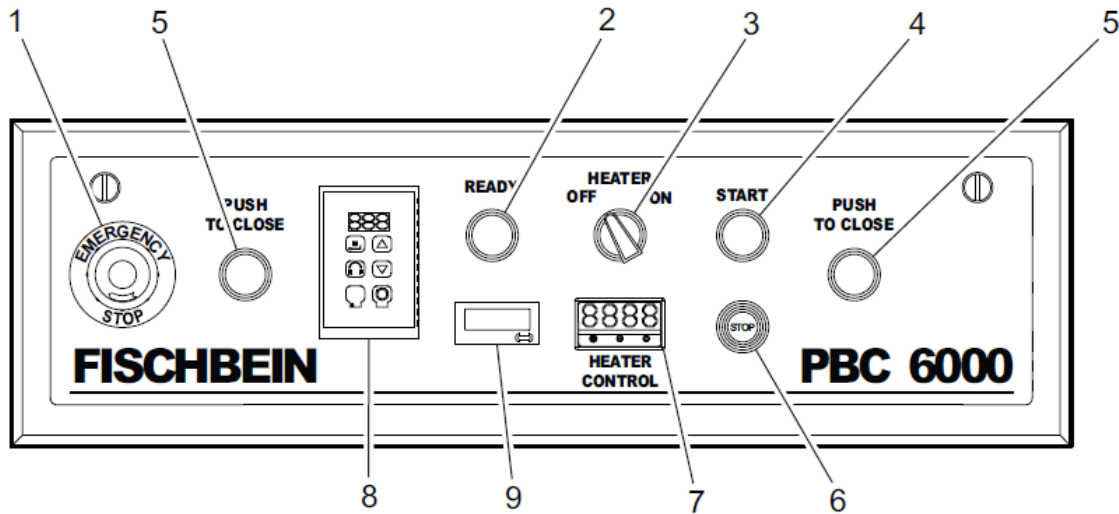

Figure 2-3: Control Panel Layout



## 1. EMERGENCY STOP Button

The EMERGENCY STOP button is only used in an emergency situation, when the belts and heater both must be shut off immediately. Push the EMERGENCY STOP button in to stop the machine and open the swing channel. Twist to the button clockwise and pull it out to release.

## 2. PUSH TO CLOSE Buttons

These two buttons close the Swing Channel, bringing the carry through and compression belts together. Both buttons must be pressed at the same time. They are placed far apart so that the operator must use both hands to press both buttons. This is a safety feature to ensure that the operator does not have his/her hands between the channels when they close.

**WARNING: KEEP HANDS CLEAR OF THE SWING CHANNEL WHEN IT IS CLOSING! NEVER ATTEMPT TO CLOSE THE SWING CHANNEL WHILE HANDS ARE IN BETWEEN**



**THE TWO CHANNELS. NEVER ATTEMPT TO DISABLE ONE OF THE "PUSH TO CLOSE" BUTTONS OR CIRCUMVENT THE SAFETY FEATURE IN ANY WAY. FAILURE TO HEED THESE WARNING COULD RESULT IN SERIOUS BODILY INJURY.**

## 3. KEYPAD

The keypad is an operator interface with the motor controller that enables the operator to set the speed of the carry through belts. It also displays drive faults.

## 4. READY Light

The READY Light will illuminate when the heaters are enabled. The heaters are enabled when the following conditions are met:

- The HEATER ON/OFF switch is on
- The belt motor has been started
- There is positive air flow to the heaters
- The EMERGENCY STOP button is not engaged
- The heaters are up to temperature

## 5. HEATER ON/OFF Switch

The HEATER ON/OFF switch allows the power to the heating element to be turned on or off.

## 6. START Button

When pressed, the control system and the temperature controller are started, confirmed by the green light. If all of the required conditions are met, the heater will also start heating. If the Motor Mode Switch is set to the AUTO position, the motor will not start turning until the PUSH TO CLOSE buttons are pressed.

## 7. STOP Button

Pressing the red STOP button will stop the belts, open the swing channel and disable the heaters.

## 8. HEATER CONTROL

The HEATER CONTROL allows the operator to set the desired temperature and monitor the temperature on the read-out. Please refer to the temperature controller operating manual, included with the machine.

## 9. BAG COUNTER

The bag counter provides a digital read out of the number of bags that have passed through the machine. The sensors, located on the underside of the Swing Channel and Fixed Channel, near the infeed end, reads the bags as they pass through the machine. A reset button on the lower right-hand corner of the counter allows the counter to be reset to zero.



## 2.4. Performance Characteristics

### 2.4.1. SYSTEM SPEED RANGES

- Range 1: Standard 30-75 feet per minute (9,1 - 22,86 meters per minute)
- Range 2: Greater than 75 feet per minute (25,9 meters per minute)
- Range 3: Less than 30 feet per minute (9,1 meters per minute)

**Note: Speeds above 85 fpm (22,86 mpm) are obtainable on request; however, they are dependent on bag types. Please consult with your Fischbein representative to determine machine capabilities for given closing requirements.**



### 2.4.2. BAG SIZE RANGE (EMPTY)

- Width: Variable
- Length: 56 inches (1422mm) maximum
- Maximum Free Top: 6 inches (153mm) (standard fold minimum)

### 2.4.3. MISCELLANEOUS

- Bag Jam Detector:

A proximity switch that shuts the heaters off and swings open the front channel in the event of a detected bag jam. Still allows air to flow through the hot air manifold to cool the heaters and prevent any damage.

- Overheat Sensor:

Shuts down the heaters if the temperature rises above a set maximum. Still allows air to flow through the hot air manifold to cool the heaters and prevent any damage.



## 2.5. System Characteristics

### 2.5.1. ELECTRICAL REQUIREMENTS

Note: The following electrical information is in accordance with provision 4.7.1 of NFPA 79 (National Fire Protection Association) Electrical Standard for Industrial Machinery, 2015 edition.

Table 2-1: Electrical Requirements

Model	Electronics	Voltage	Phase	Hertz	F.L.A.	Max. Motor F.L.A.
PBC6000	NEMA 12	230	3	60	19	2.4
PBC6000	NEMA 12	230	1	60	22	2.4
PBC6000	NEMA 12	460	3	60	10	1.2

### 2.5.2. PHYSICAL CHARACTERISTICS

- Total palletized system weight: 855 lbs. (387.82 kg)
- Total system weight: 795 lbs. (360.61 kg) (standard machine)
- Air Consumption Minimum Requirement: 420 SCFH (11,9 SCMH)
- Air Pressure Requirement: 90 PSI (6,2 bar) (with ½ inch air line)
- Swing Channel Design: The PBC6000 is designed with a front breakaway channel, which swings outward. This allows quick access into the machine for safety, to clear bag jams, cleaning and maintenance.
- Air Scrubber: Blows debris from the bag top that could otherwise prevent a good seal.
- Caster Wheels: Two locking in the back and two standard wheels in the front.



### 2.5.3. SYSTEM DIMENSIONS

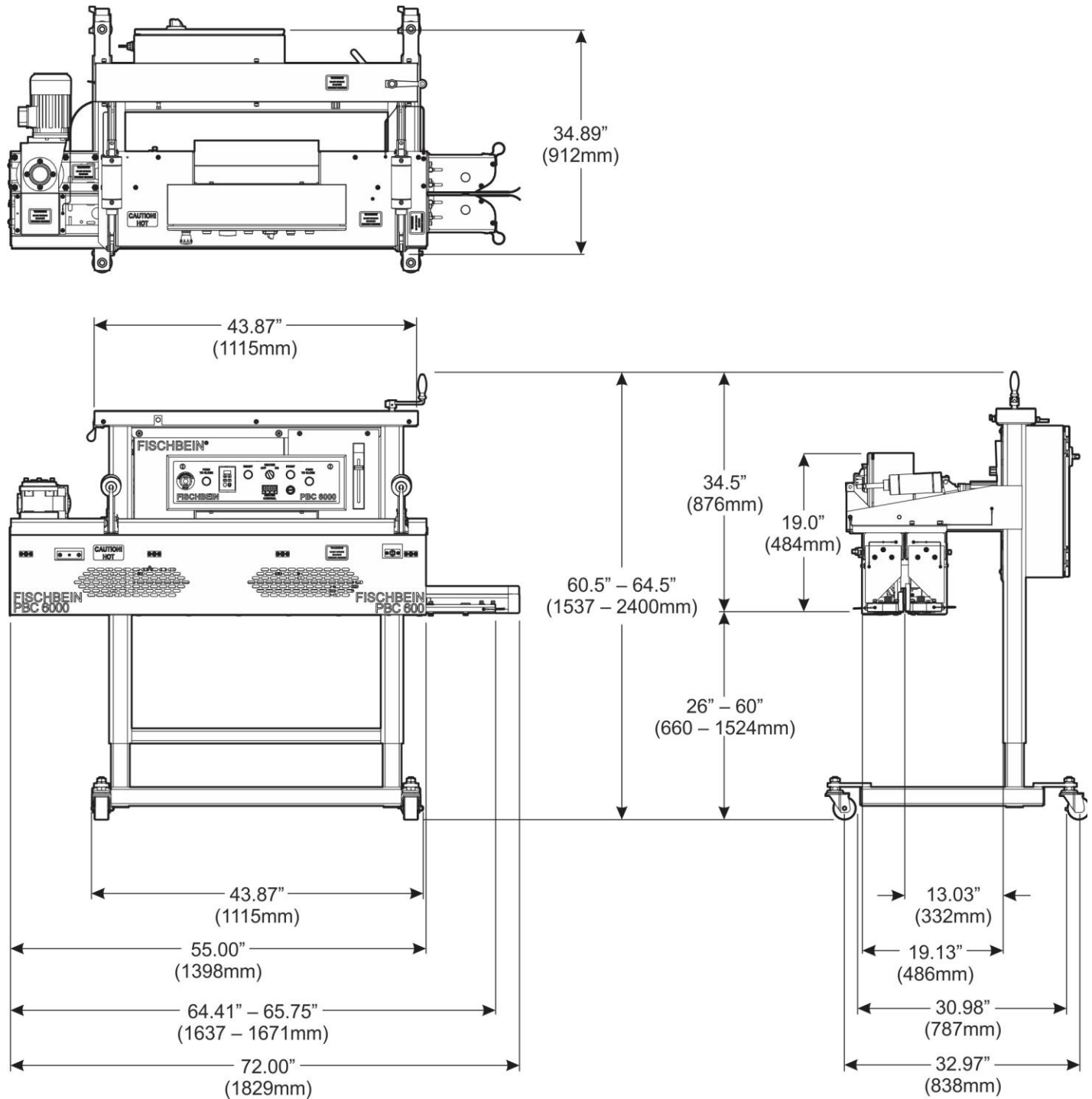

**Figure 2-4: PBC6000 Right-to-Left Standard Pinch Bag Closer Dimensions**

\*Standard length automated infeed shown. Customers' machine may differ in appearance.



### 3. INSTALLATION

#### 3.1. Recommended Work Area Layout

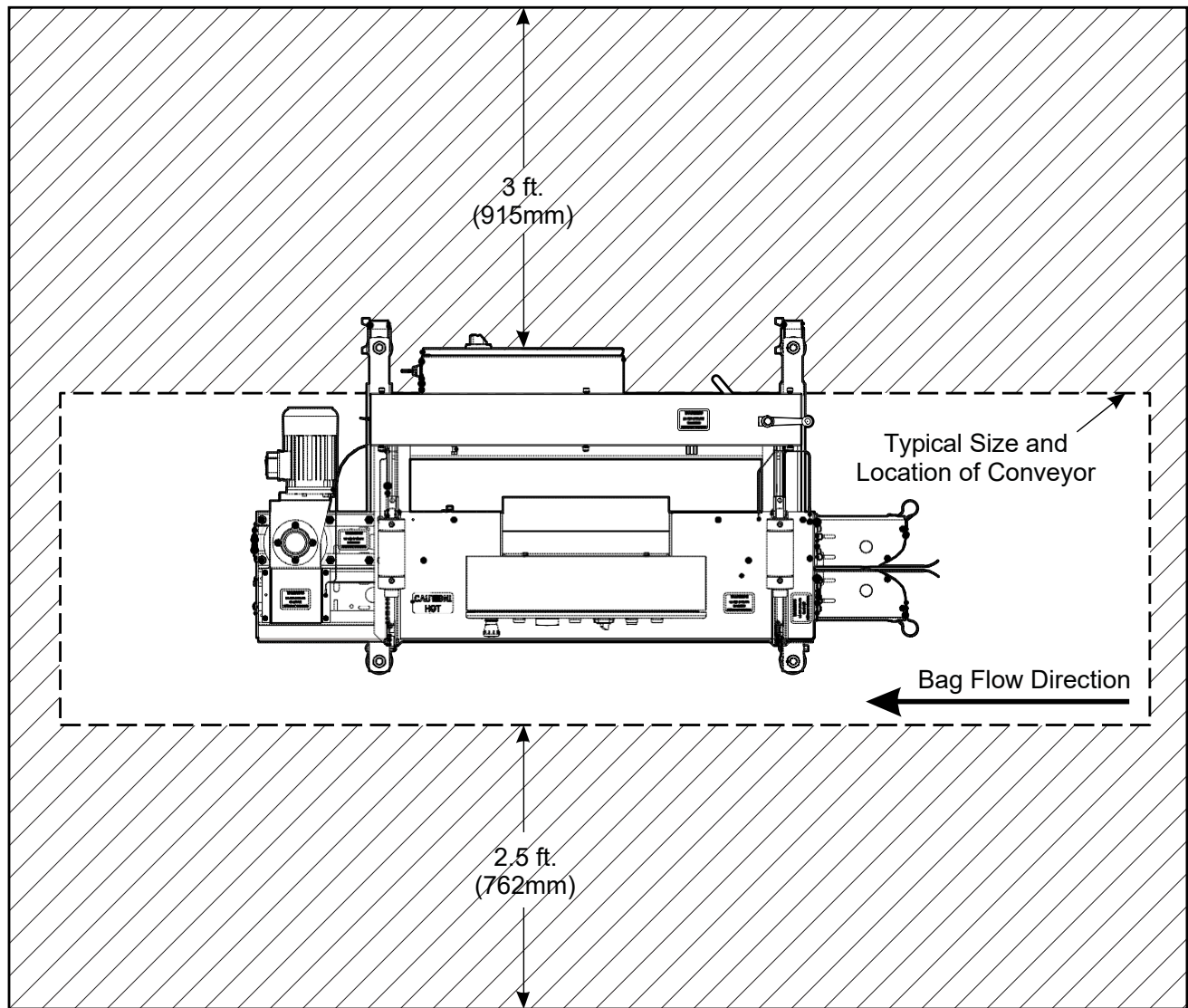

Figure 3-1: Recommended Work Area Layout

#### 3.2. Site and System Preparation

##### 3.2.1. ELECTRICAL POWER HOOKUP

The system is wired at the factory for the voltage specified when ordered.



**CAUTION: BE SURE TO WIRE WITH MINIMUM SO 12/4 (12 AWG/4 WIRE) (4 MM<sup>2</sup>), 300 V FOR 230 V SYSTEMS AND 600 V FOR ABOVE 230 V SYSTEMS.**



**CAUTION: BE SURE THAT THE MACHINE IS CONNECTED TO THE BUILDING GROUND.**



Follow National Electrical Code (NEC) and any local electrical codes during installation.



**WARNING: SHOCK HAZARD! BE SURE TO TURN OFF AND LOCK OUT POWER SUPPLY**

Model	Electronics	Voltage	Phase	Hertz	F.L.A.	Max. Motor F.L.A.
PBC6000	NEMA 12	230	3	60	19	2.4
PBC6000	NEMA 12	230	1	60	22	2.4
PBC6000	NEMA 12	460	3	60	10	1.2



**Note:** Electrical schematics for each unit's particular voltage option are shipped inside the electrical enclosure. For load specifications, refer to the machine information label located on the side of the electrical enclosure.

After connecting the supply power to the PBC6000, check the infeed motor for proper rotation. The infeed belt must turn in the same direction as the bags flow through the machine. If the motor does not have the proper rotation, switch two of the phases of the power at the machine's main switch.



**CAUTION: BE CAREFUL WHEN CHECKING THE ROTATION OF THE INFEEED MOTOR.**

### 3.2.2. PNEUMATICSHOOKUP

Connect the air source with a female quick release air coupling (Foster Series 3, #3003 or equivalent) to the safety shut-off valve, located on the pneumatic control panel (see Figure 3-2: Pneumatics Dia- gram and Schematic). Air hose connections must have a minimum ½ in. (13 mm) ID. The PBC 6000 requires compressed, clean, dry, non-lubricated air. The supply must be capable of sustaining 90 PSI (6,2 bar) of pressure and a volume flow rate of at least 400 SCFH (11,3 SCMH).



**WARNING: REMOVAL OF THE QUICK DISCONNECT COUPLING MAY VIOLATE OSHA SAFETY REGULATION #1910 (CONTROLLING HAZARDOUS ENERGY) AND MAY RESULT IN SERIOUS INJURY.**

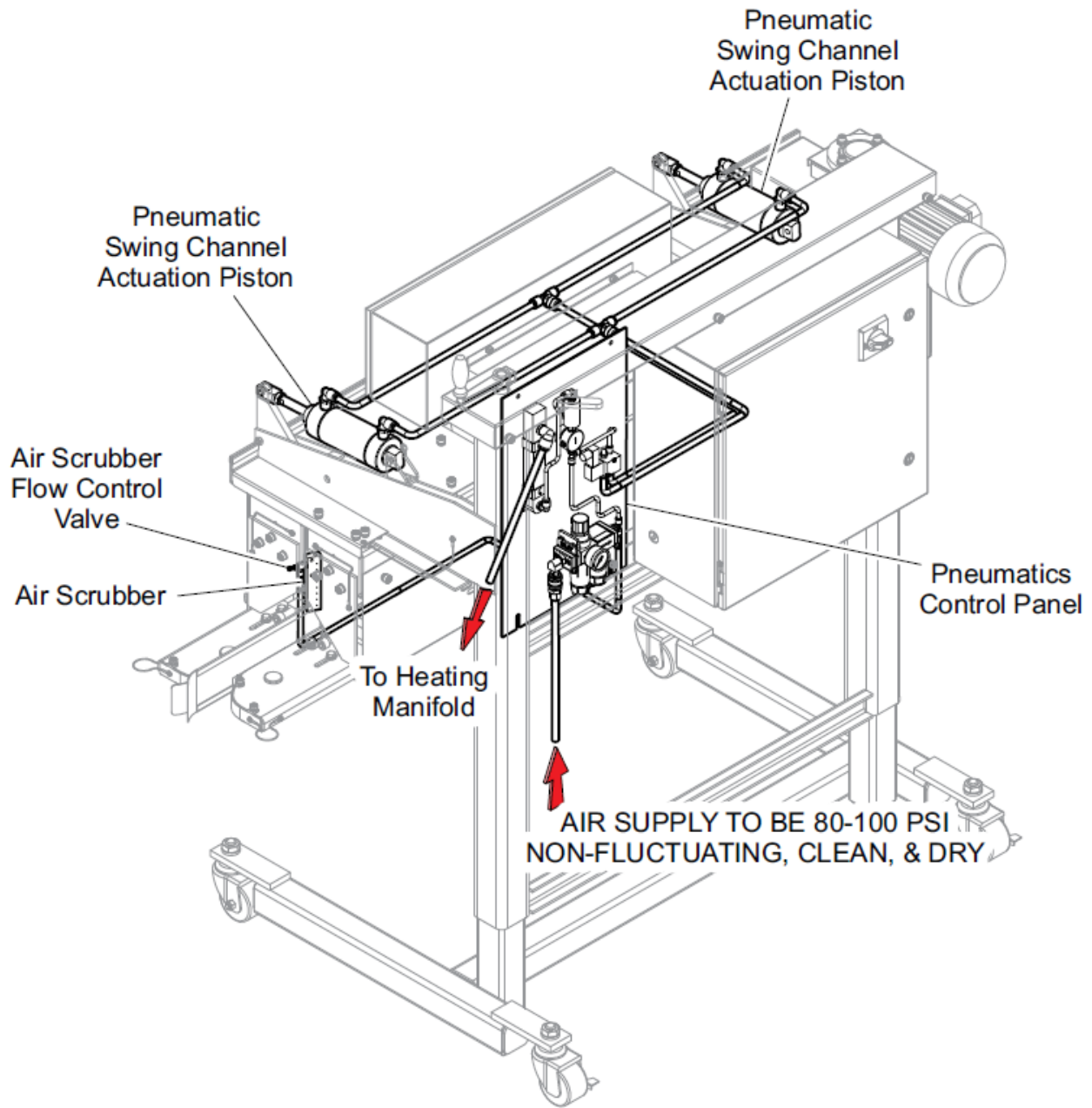
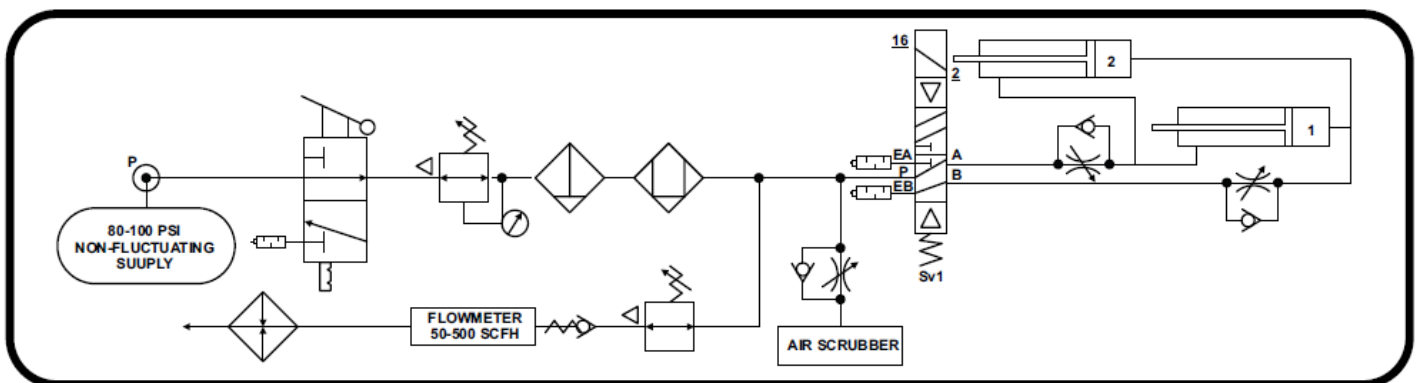

Figure 3-2: Pneumatics Diagram and Schematic





## 3.3. Unpacking Procedure

Each PBC6000 is packaged to protect the unit during normal shipping, storage and handling. Before the unit is unpacked, inspect the box and skid for any signs of damage due to shipping. If possible, record any signs of shipping damage with a digital camera. Report any damages in writing to the shipper and your representative.



**CAUTION: A PALLETIZED PBC6000 WEIGHS APPROXIMATELY 795 LBS (360.61 KGS) AND MEASURES 74' X 56" X 71" (1880MM X 1422MM X 1803MM). UNPACK THE PBC 6000 AS CLOSE AS POSSIBLE TO WHERE IT WILL BE INSTALLED.**

Tools needed to unpack a unit include a knife, claw hammer, pry bar, adjustable wrench or air wrench, and a forklift or overhead hoist with a hoist strap.

1. Cut the two plastic binding straps and remove the box lid. At least 7 ft. (2,13 m) overhead clearance will be needed to remove the box itself.
2. Using a pry bar and claw hammer, pry out the nails that fasten the box to the pallet. With the aid of one other person, carefully lift the box up and off the machine.
3. Cut away and remove the film or bag covering the unit inside the box. Find and remove the moisture absorbing packet(s) before continuing to unpack and install the system.
4. Remove the lag bolts securing the frame to the crate's pallet. Locate the box of casters in the crate and prepare to mount them on the machine.



**CAUTION: BE CERTAIN THAT NONE OF THE PNEUMATIC OR ELECTRICAL CONNECTIONS ARE PINCHED BEFORE LIFTING THE SYSTEM.**

5. Using 1000 lb-rated hoist straps, loop them around the overarms of the machine's frame (see Figure 3-3: Lifting the Machine). Make sure the straps do not pinch any wires or pneumatic hoses. Loop the straps securely over the forks of a forklift or an overhead hoist.



**CAUTION: DEPENDING ON THE CONFIGURATION OF THE MACHINE, EXPECT THE SYSTEM TO TILT FORWARD WHILE IT IS BEING LIFTED.**

6. Use the forklift from the front or back of the machine to raise the machine above the pallet just enough to slide the pallet from under the machine (see Figure 3-3: Lifting the Machine). Each side of the machine must be monitored as the machine is slowly lifted. Monitors must allow the machine to gently tilt forward, but prevent the machine from swinging.
7. Remove the pallet, mount the casters (locking casters in the rear) and lower the machine to the floor.
8. Roll the machine to the desired work area. Be sure to provide the needed space around the system as shown in Figure 3-1: Recommended Work Area Layout.
9. Lock the rear caster wheels once the machine is in place.



**CAUTION: THE MACHINE SHOULD NEVER BE OPERATED WITH THE SWING CHANNEL HOLDING PIN INSTALLED!**



10. The swing channel is held in the down position by a holding pin, installed for shipment only. This pin must be removed before operating the machine for the first time (see Figure 3-3: Lifting the Machine).

 **NOTE:** The front swing channel will rotate open once the pin is removed.

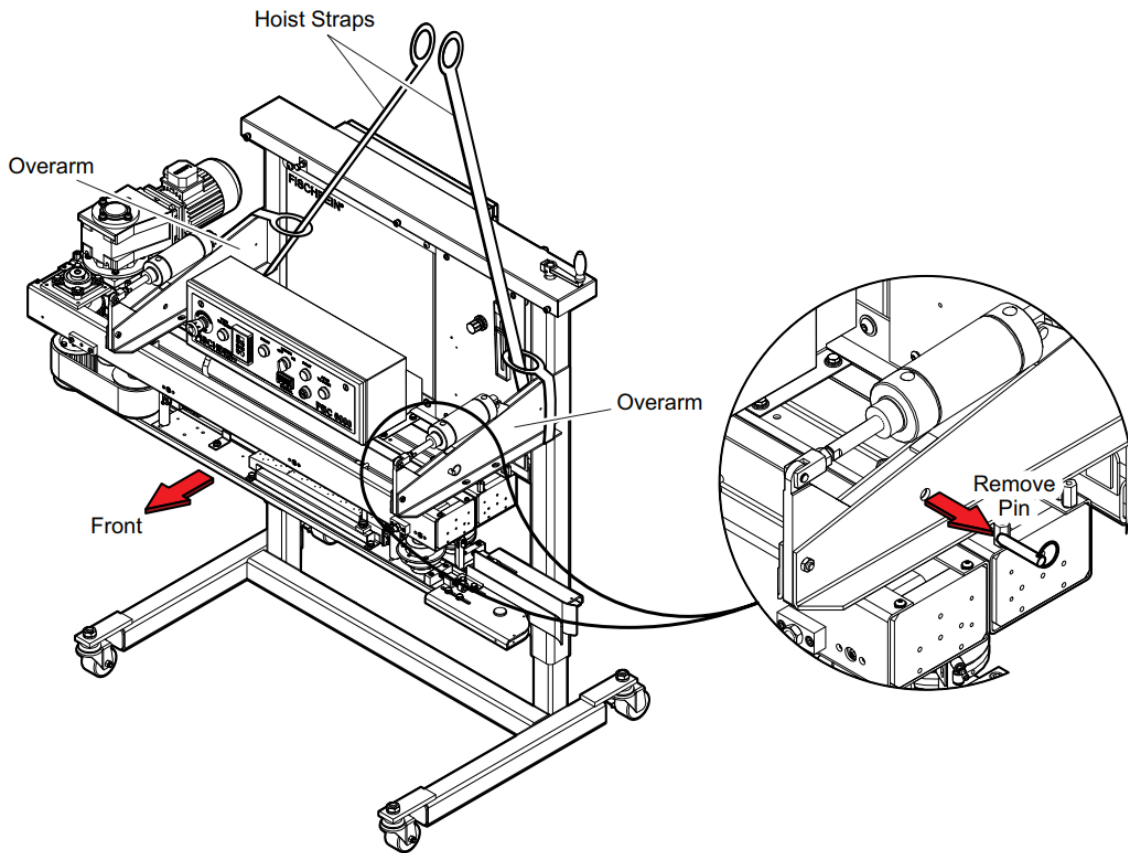

**Figure 3-3: Lifting the Machine**

11. Once the machine is completely unpacked, inspect it for physical damage or missing components. Report anything missing or any damaged in writing to the shipper and your Fischbein representative.



### 3.4. On Line Preparation

#### 3.4.1. SAFETY GUIDELINES



**CAUTION: OPERATORS MUST BE FULLY TRAINED ON THE PERFORMANCE, OPERATION, ADJUSTMENTS AND SAFETY STANDARDS OF THIS MACHINE BEFORE ATTEMPTING TO OPERATE IT.**



**WARNING: LONG HAIR MUST BE PULLED BACK AND TIED TO AVOID GETTING CAUGHT IN ANY MOVING PARTS OF THE SYSTEM.**



**WARNING: OPERATORS MUST NOT WEAR LOOSE CLOTHING OR JEWELRY WHILE WORKING AROUND THIS MACHINE.**



**WARNING: OPERATORS MUST WEAR PROPER EYE PROTECTION WHILE WORKING AROUND THIS MACHINE.**



**WARNING: OPERATORS MUST WEAR PROPER FOOT PROTECTION WHILE WORKING AROUND THIS MACHINE.**



**WARNING: OPERATORS MUST WEAR GLOVES WHEN WORKING AROUND THE HOT OR SHARP MACHINE SURFACES.**



**WARNING: THE SURROUNDING AREA AROUND THE MACHINE MUST BE KEPT CLEAR OF OBJECTS AND POTENTIAL HAZARDS SO THE OPERATOR CAN HAVE QUICK EASY ACCESS TO ANY PART OF THE MACHINE.**



**WARNING: THE MACHINE MUST NEVER BE OPERATED WITHOUT ALL OF ITS COMPONENTS. THE COVERS, GUIDES, GUARDS AND SHROUDS MUST BE INSTALLED ON THE MACHINE WHEN BEING OPERATED.**



**CAUTION: ONLY USE THE MACHINE FOR ITS INTENDED USE.**

The machine is equipped with a three position Motor Mode Switch, located on the side of the electrical enclosure (see Figure 3-4: Power Disconnect/Power Lock-out Switch and 3-Position Motor Mode Switch). The **AUTO** position is used during normal operation of the machine. The drive motor will only activate when the swing channel begins to close. The **STOP** and **RUN** positions are provided only for technicians, to perform maintenance on the machine. The **STOP** position disables the drive motor, but will still allow the pneumatic controls to work. The **RUN** position is used to enable the drive motor only when the machine is powered. This mode does permit the drive motor to rotate, when the swing channel is open.

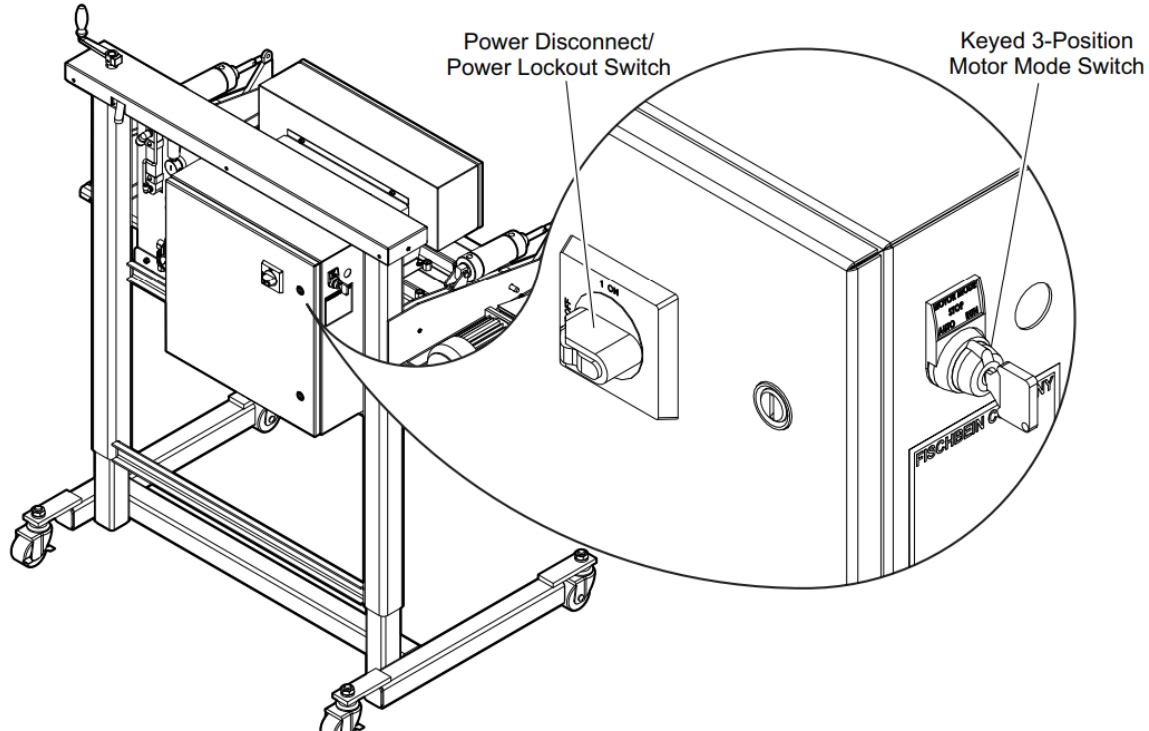

Figure 3-4: Power Disconnect/Power Lock-out Switch and 3-Position Motor Mode Switch

### 3.5. Electrical System

The system is wired at the factory for the voltage specified when ordered. Customers are required to supply incoming electrical connections. So, 12/4 (12 AWG/4 wire) (4 mm<sup>2</sup>) is recommended.



**CAUTION: BE SURE THE MACHINE IS CONNECTED TO BUILDING ELECTRICAL GROUND.**

Follow National Electrical Code (NEC) and all local electrical codes during installation.



**NOTE:** Electrical schematics for each unit's particular voltage option are shipped inside the electrical connection box on the back of the unit. For load specifications refer to Table 2-1: "Electrical Requirements," on page 2-7.

**WARNING:** WHILE PERFORMING MAINTENANCE TO THE MACHINE, ALWAYS TURN "OFF" AND LOCK OUT THE ELECTRICAL SUPPLY (SEE FIGURE 3-4: POWER DISCONNECT/POWER LOCK-OUT SWITCH AND 3-POSITION MOTOR MODE SWITCH). OPERATE THE MACHINE WITH THE DESIGNED ELECTRICAL SERVICE. NEVER ALTER THE ELECTRICAL SYSTEM OF THE MACHINE.





### 3.6. Pneumatics System

Connect the air source with a female quick release air coupling (Foster Series 3, #3003 or equivalent) to the safety shut-off valve located on the pneumatic control panel (see Figure 3-5: Pneumatic System Controls). Air hose connections must have a minimum 1/2 in. (13 mm) ID. The machine requires compressed, clean, non-lubricated air. The supply must be capable of sustaining 90 PSI (6,2 bar) of pressure and a volume flow rate of at least 400 SCFH (11,3 SCM/H).

The pneumatics control panel is equipped with a safety control valve. While performing maintenance on the machine, the pneumatic supply must be turned OFF and locked out (see Figure 3-5: Pneumatic System Controls). When shutting down the machine, always be sure that the heaters have COMPLETELY cooled before turning off the pneumatic supply. Not allowing the heaters to cool will damage the heater element and the pneumatic tubing. The machine usually takes approximately 10-20 minutes to cool down enough to turn off the air supply under normal conditions.

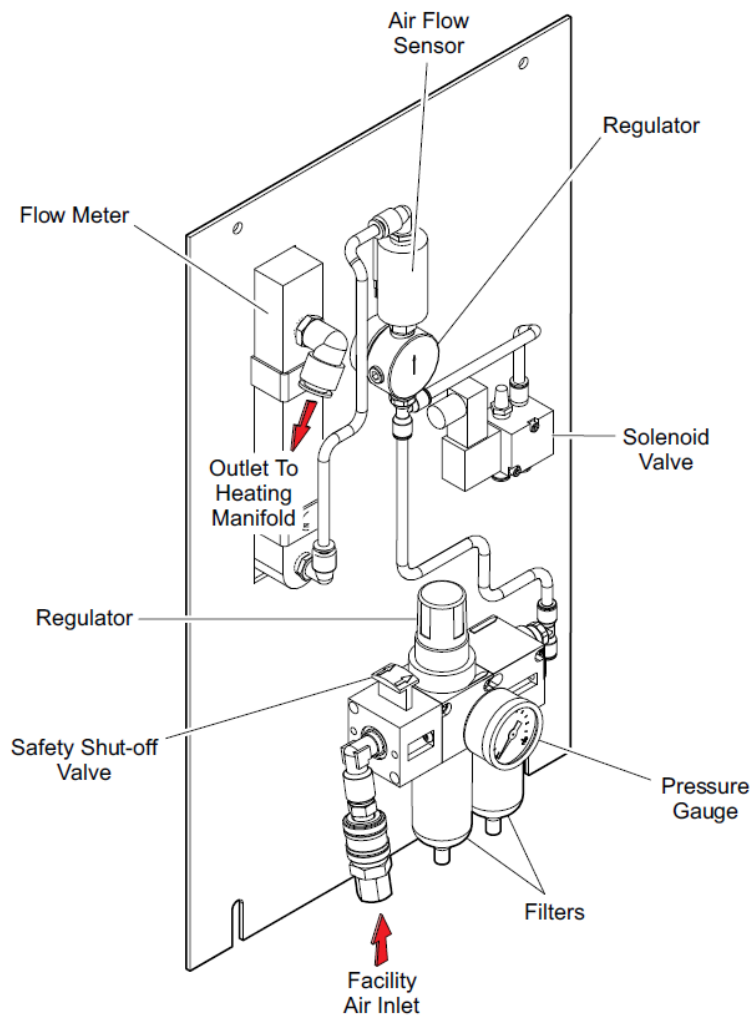

Figure 3-5: Pneumatic System Controls



### 3.7. Leveling and Centering

The quality of the bag seal depends on a number of factors. The most basic of these factors is whether the bag is being fed into the machine correctly. When first preparing the machine for operation, it must be properly placed vertically and horizontally in relation to the conveyor system.

#### 3.7.1. LEVELING

To maintain an even fold on the bag top, the sealing operation of the machine must run parallel to the conveyor. To check this, measure the distance between the bottom of the carry through belts and the surface of the conveyor belts. This distance should be the same at both the input and output ends of the machine (see Figure 3-6: Machine Leveling). If there is a significant difference, the bag seal will be uneven from leading to trailing edge of the bag. Make the necessary adjustments to achieve a parallel and straight seal line.

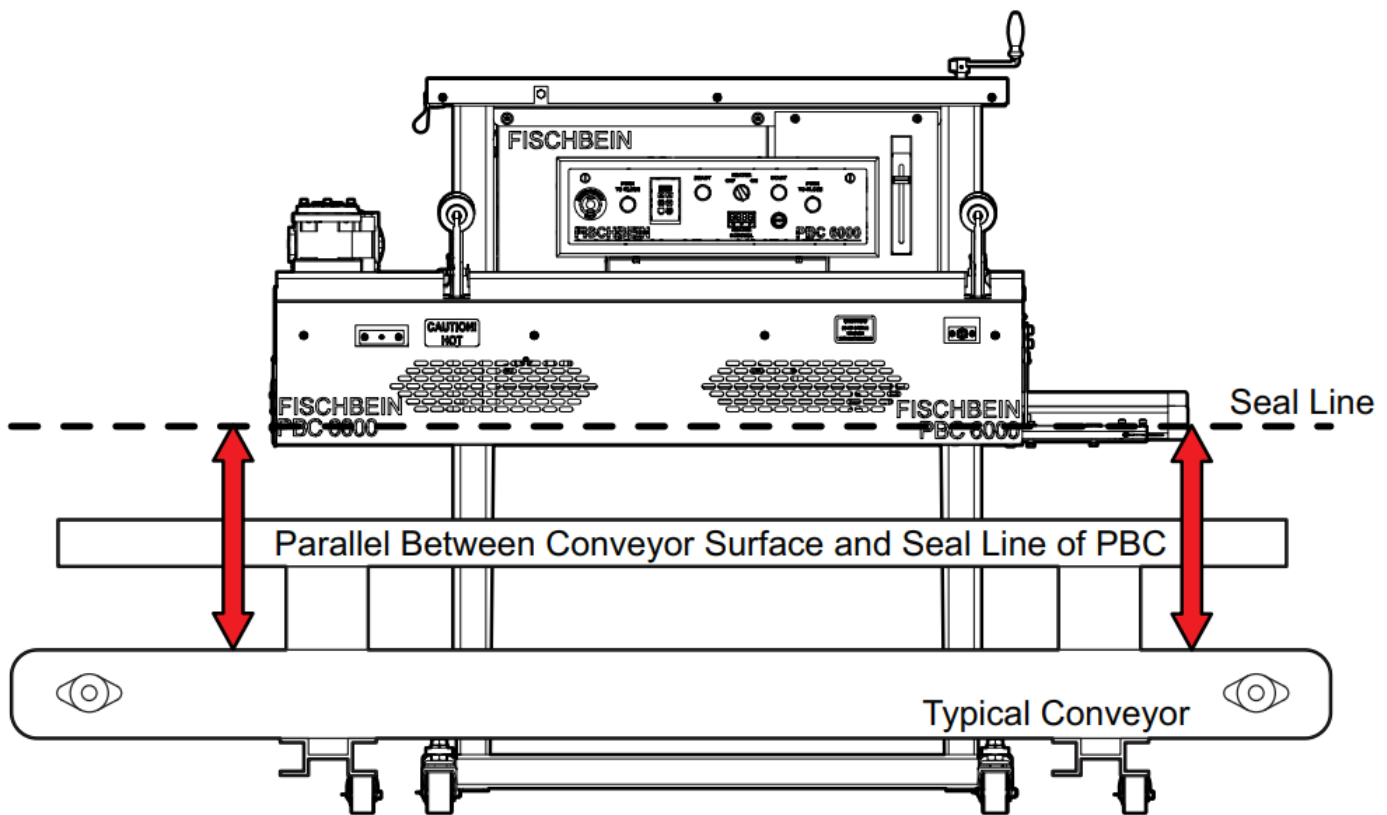
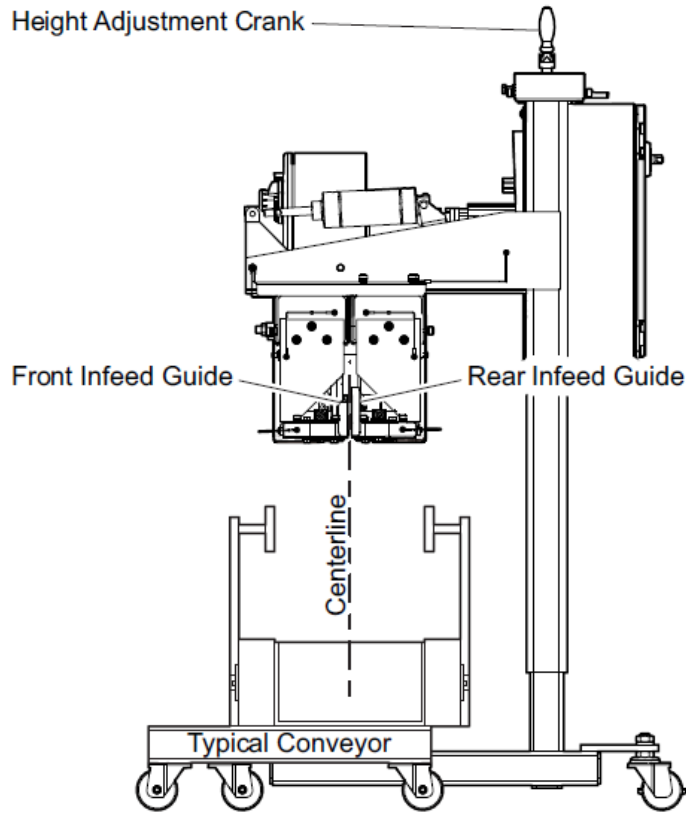

Figure 3-6: Machine Leveling

#### 3.7.2. CENTERING

There are two conditions to satisfy the centering required for a good seal. The first is where the two carry through belts come together to grasp the bag top. This point must be centered above the middle of the conveyor (i.e. the centerline of travel for the bags' path) (see Figure 3-7: Centerline Travel of Bags' Path). If a bag enters the system too far towards the back or front of the machine, the bag may not enter the system straight (affecting the seal quality) or the bag may be tilted too far and tip over. If the bags are being fed into the system manually, the operators should be careful to center the bags between the carry through belts. For automated systems, the machine can easily be moved after unlocking the two rear casters.



**Figure 3-7: Centerline Travel of Bags' Path**

The second condition involves centering the bag top vertically with the carry through belts. The height adjustment on the machine is used to bring the machine's creaser wheel (the device used to create the crease-line for the fold) to the correct elevation with the entering bags. To determine the correct height, allow a filled bag sample to come up to the infeed on the PBC and then stop the conveyor system.

Note the location of the glue line on the bag top. The bottom edge of the glue line should be just above the creaser wheel. It can be a little higher, but the crimp must be made below the bottom of the glue edge (see Figure 3-8: Bag Free Top).

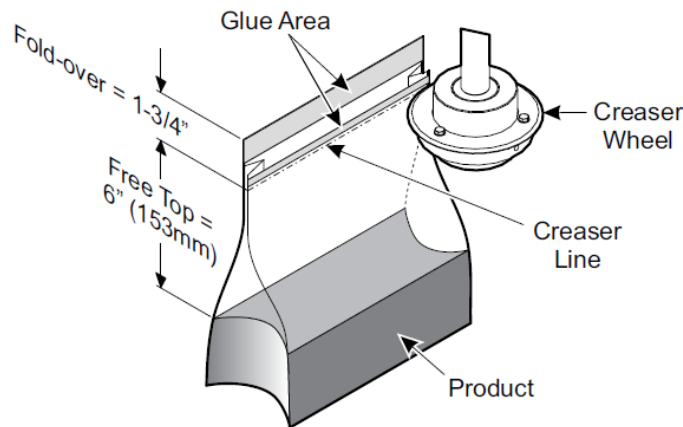

**Figure 3-8: Bag Free Top**



Free top is the term used to describe the distance between the top edge of the unfolded bag and the top surface of the product in the bag (see Figure 3-8: Bag Free Top). For best results, the machine requires a free top of 6 inches (153 mm) for standard size folds and greater than 6 inches for wider folds. Using a shorter free top may cause the bag to bulge and be torn by the shrouds.

### 3.8. Speed Checks and Synchronization

Synchronizing the machine involves adjusting external and internal rates to provide a good strong seal. The external synchronization is between the machine and the conveyor system. The carry through belts of the machine provide the speed for folding and sealing the bag top. These belts must be set to run at the same linear rate as the conveyor system. If the timing between the two systems does not match, the bag will be tilted forward or backward and will not completely seal the bag. Use a hand-held tachometer set for measuring feet per minute or meters per minute and check the linear speeds of the two systems. The machine's speed can easily be adjusted by pressing the up or down arrows on the keypad (see Figure 3-9: Speed Control). The UP arrow increases the speed, while the DOWN arrow decreases it. Always remember to adjust the speed of the machine when the line speed changes.

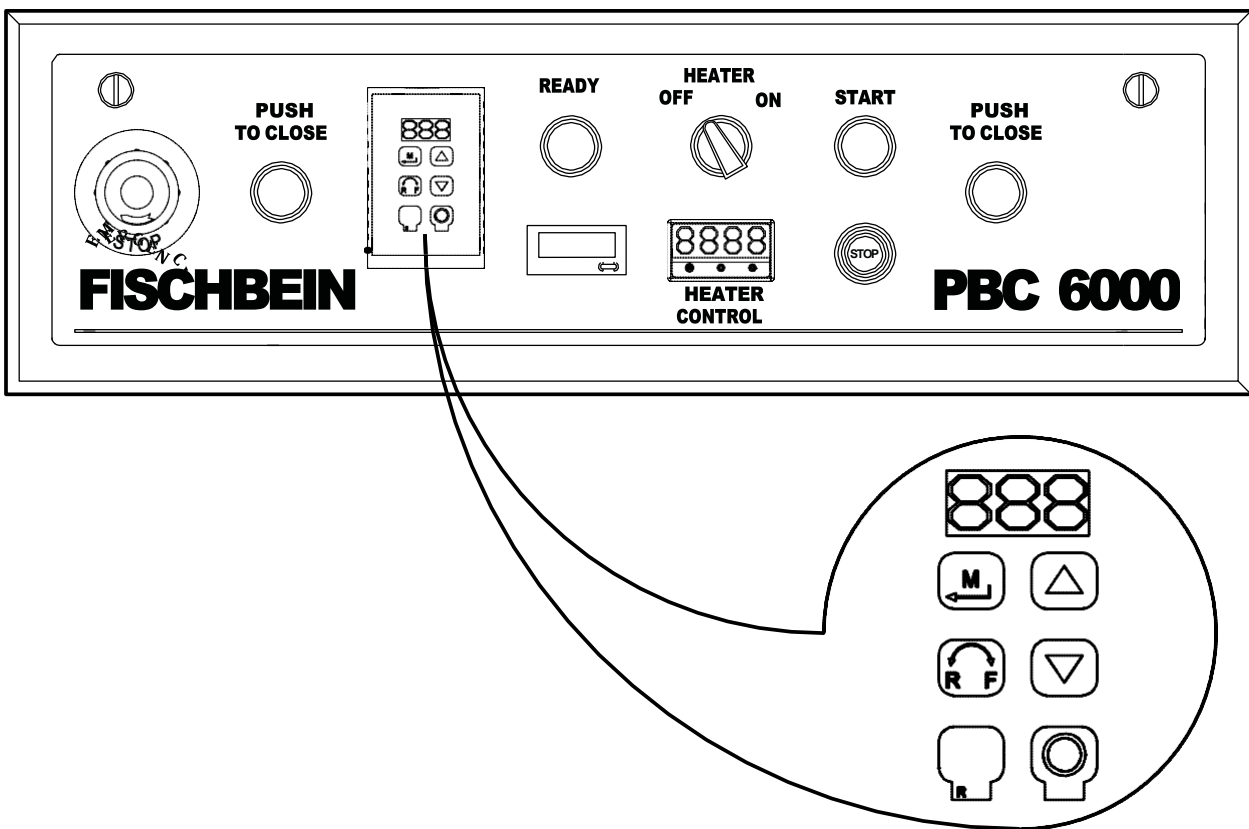

Figure 3-9: Speed Control

The internal synchronizing of the machine is between the rear (fixed channel) and front (swing channel) belts. The drive system within the two channels is synchronized by two large spur gears, beneath the drive gear motor (see Figure 3-10: Drive System). A pulley drives the carry through belts at the end of the drive shafts on the underside of the machine. If the belts are loose, they may slip while passing over the drive pulleys and skew the bag top as a result. Make sure the belts are tight before operating or synchronizing the machine. To tighten the carry through belts, refer to “CARRY THROUGH BELTS” on page 5-1. Although the compression belts must also be synchronized, it is not likely that they will be different since they are toothed timing belts, turned by timing sprockets. However, if they become loose, refer to “COMPRESSION BELTS” on page 5-4 to adjust and tighten them.

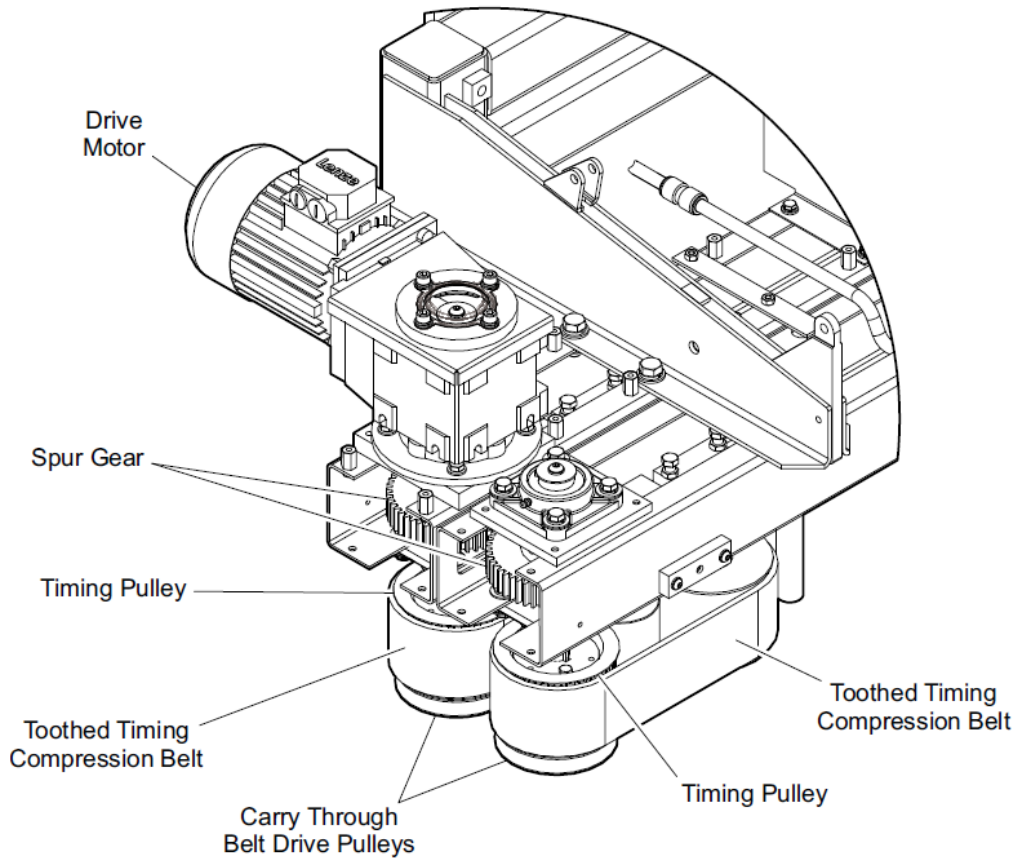

Figure 3-10: Drive System

### 3.9. Folder

Check the folder assembly to ensure that it is not loose and remove any glue build up on the edges. The bag must be able to flow through the folder without catching on edges or glue remnants. If the bag thickness is being changed, run test bags through the machine first to ensure that the folder is set properly to make a complete, even seal. The folder should not have to be adjusted for most common bag types and thicknesses. If minor adjustments are required, refer to “Folder and Bottom Folder Guide Adjustment” on page 5-15.

### 3.10. Compression Belts and Rollers

Check the compression belts for gouges and glue buildup. Carefully remove the glue with a dull edged tool. The belt should be tight on the rollers and wheels. Where the two compression belts come together, they should just be touching. If they are coming together with too much or too little force, the seal on the bag could be wrinkled or not completely sealed. To adjust the compression section of the machine, refer to “Compression Belt Pressure Adjustment” on page 5-5.



### 3.11. Setting the Temperature

The temperature of the heater is controlled and regulated by the temperature controller located on the control panel. (see Figure 3-11: Heater Controls). The temperature should be set based on the following criteria:

1. Type of adhesive used on the bag (i.e. glue melting point)
2. Speed of the conveyor system
3. Room temperature
4. Ambient bag temperature
5. Relative humidity of the bag material

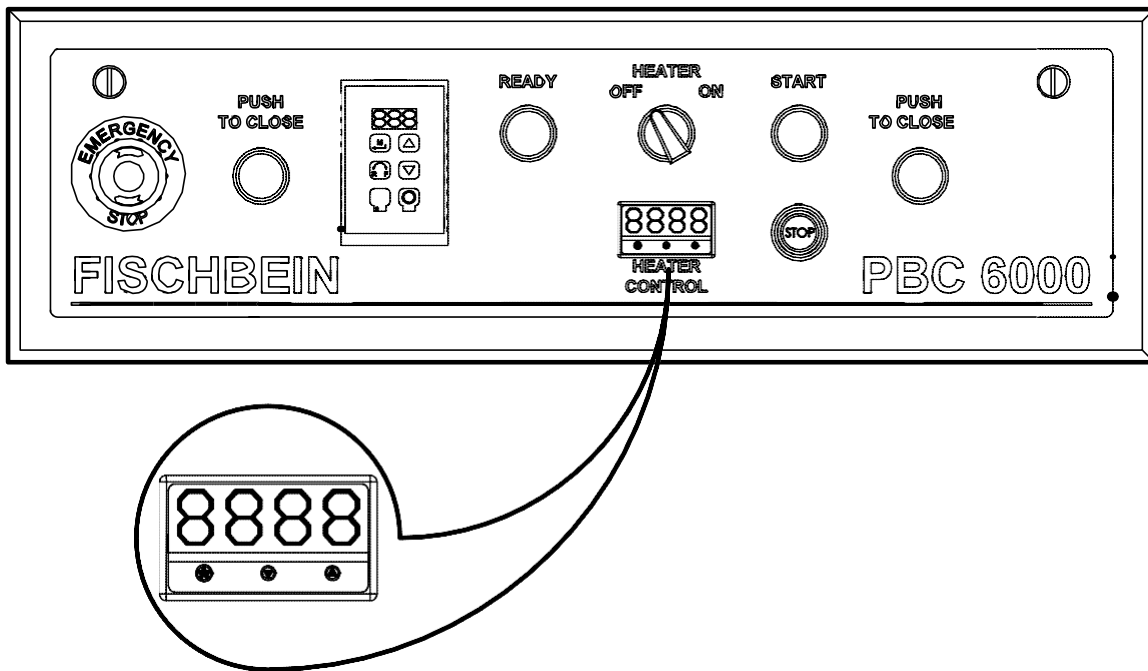

Figure 3-11: Heater Controls

Since the bag and glue take time to heat up, the faster the system is required to seal bags, the higher the temperature setting must be.



**WARNING: KEEP IN MIND THAT EVERY TIME THE CONVEYOR AND MACHINE SPEED IS CHANGED, THE TEMPERATURE SHOULD BE CHANGED. LEAVING THE TEMPERATURE SET HIGHER THAN NEEDED FOR A NEW SETTING, MAY CAUSE THE BAG OR GLUE TO CHAR. THIS IS A FIRE HAZARD AND MUST ALWAYS BE AVOIDED!**



## 3.11.1. DETERMINING THE CORRECT TEMPERATURE

The machine is designed to accommodate a variety of heat-activated glues. Each type of bag could require a different temperature setting for a variety of production line speeds. Check with the bag supplier, to determine the temperature needed to melt the glue. Due to the rate at which the bags pass through the system and the thermal properties of the bag, the temperature will have to be set higher than the glue's melting point. For safety, always start at a lower temperature and slowly increase the setting as needed. For many common bag types and a line running at 40 -45 FPM (12,2 -13,7 MPM), the temperature can be set at 450°F (232°C).

The room temperature and humidity can affect the seal quality. It is important to always keep in mind all conditions while operating the machine. The temperature of the bag material when it passes into the machine will also determine the setting for the temperature. It is best to allow the bags to reach room temperature before filling and sealing them. Always allow the machine to heat up completely before adjusting the temperature. (Approximately: 20-30 minutes)

The temperature should be adjusted accordingly while the machine is being operated. Take time during the operation of the machine to inspect the seal quality and then adjust the temperature as needed.

**Note: Keep a record of the ambient room temperature, bag type and the production line speed in order to reduce the set up time for determining the temperature settings, when changes occur.**

After reaching the desired temperature setting, test a couple of bags and inspect them. The glue must be making a strong bond to the bag. You can test this by gently pulling open the bag, after it has cooled. If the glue is bonding correctly, fibers of bag material will be sticking in the entire adhesive area. If the bag opens easily and you can tell that parts of the glue are not bonding to the bag, the temperature setting will likely have to be increased, if the compression rollers are set correctly. Be sure to only increase the temperature in small increments of 10 - 20 degrees at a time, until the desired bond is achieved. After changing the temperature, allow the machine time to fully adjust.

If the setting is too high, parts of the glue may be charred or burnt. If the glue appears to have darkened, then the glue has begun to char. When the temperature is set too high, the glue may begin to drip off the bag and land on the manifold. Glue build up on the manifold will clog the air holes. Lower the temperature significantly and begin testing again. Always start at a lower temperature and slowly increase the setting until the desired bond is achieved.

If the glue does not appear to be making a strong bond with the bag, although the temperature is high enough to melt the adhesive, and the compression rollers are set correctly, then check the surface of the bag. If the bag surface is too dusty or has a liquid contamination on it, the glue may not properly bond with the bag fibers. The machine is equipped with an air scrubber at the infeed end of the machine. Make sure it is directed at the seal area and that it is effectively removing the debris. The air flow can be adjusted through the scrubber by rotating the flow control valve in the air line to the scrubber (see Figure 3-2: Pneumatics Diagram and Schematic).



**Note: At the factory the machine is set to the specifications defined at the time the order was taken. If sample bags were sent to Fischbein prior to shipment, the machine will be adjusted to the materials sent.**



### 3.11.2. USING THE TEMPERATURE CONTROLLER

The temperature controller is very easy to understand and use. The manual that comes with the controller (located in the electrical enclosure) contains more detailed information and instructions that are available. This manual will only cover how to read, change and autotune the controller.

#### 3.11.2.1. STARTUP

When the system's power is ON, the pneumatics are ON, the heater switch is turned ON, and the green START button is pushed, the controller's display will light up. After a few seconds the display will alternate between displaying the current temperature in the heater manifold and **-AL-**. The temperature will begin to increase indicating that the heaters are heating to bring the manifold to the set point. Once the temperature reaches the set point, the display will stop alternating displays and only show the current temperature in the manifold.

#### 3.11.2.2. SET POINT DISPLAY AND CHANGES

To display the set point, push and hold in the "\*" button. The display (see Figure 3-12: Displaying the Set Point) will alternate between the set point temperature and the temperature scale (0°C for Celsius and 0°F for Fahrenheit). To change the set point, push and hold in the "\*" button and then press the "▲" or "▼" keys to increase or decrease the setting. Release the buttons when done. Only make small increment changes to the set point until the desired closure is achieved. Be sure to allow five to ten minutes for the heaters to reach their optimum level before sealing bags.

##### START UP DISPLAY

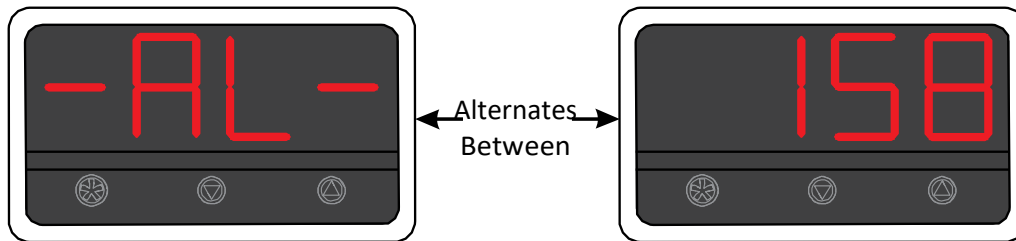

##### SET POINT DISPLAY

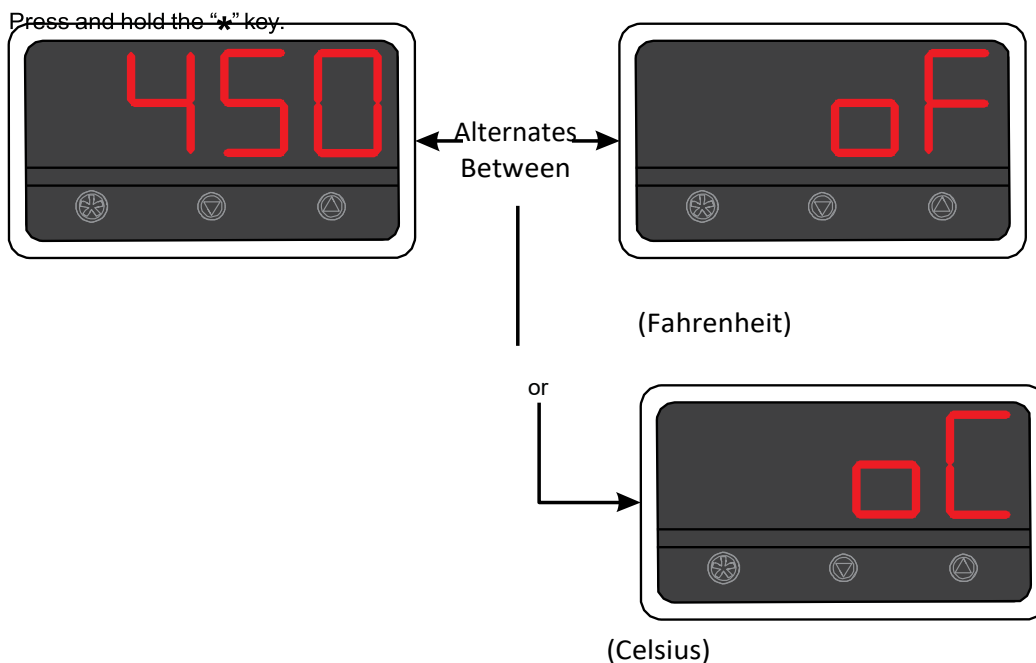



Figure 3-12: Displaying the Set Point

## 4. OPERATION

### 4.1. Operating the Machine

The machine is designed to fold, heat and then seal the top edge of a PBC bag. The system forms a crease line and then proceeds to fold the adhesive side of the bag top. When properly heated the adhesive flap will adhere to the opposite bag surface and seal the bag, preventing the product from leaking out through the top of the bag. Following is the precise details on how the machine processes a bag to seal it.

### 4.2. Process Description

Once the machine has been properly prepared (see “On Line Preparation” on page 3- 6.), the pneumatic and electrical systems are turned on. The airflow gage for the manifold should be no less than 400 SCFH (11,3 SCM/H). The heater/heaters is/are activated, and the machine is allowed to warm up for a minimum of 15-20 minutes.

A filled bag travels towards the infeed after it has been prepared by the operator. The operator reforms the gussets on the bag, "breaks" the bag top and straightens the top of the bag in preparation for the machine (see Figure 4-1: Reforming Bags before Passing through Pinch Bag Closer). In an automated system the operator does not have to manually feed the bag top into the infeed. The machine firmly grasps the bag top and transports it through the system. Just as the bag enters between the channels, the air scrubber blows dust and debris from the seal area to ensure a clean region for the glue to attach to the bag surface. After entering the machine, the bag travels between the creaser wheels, where the bag is scored below the glue line to form a line for the fold.

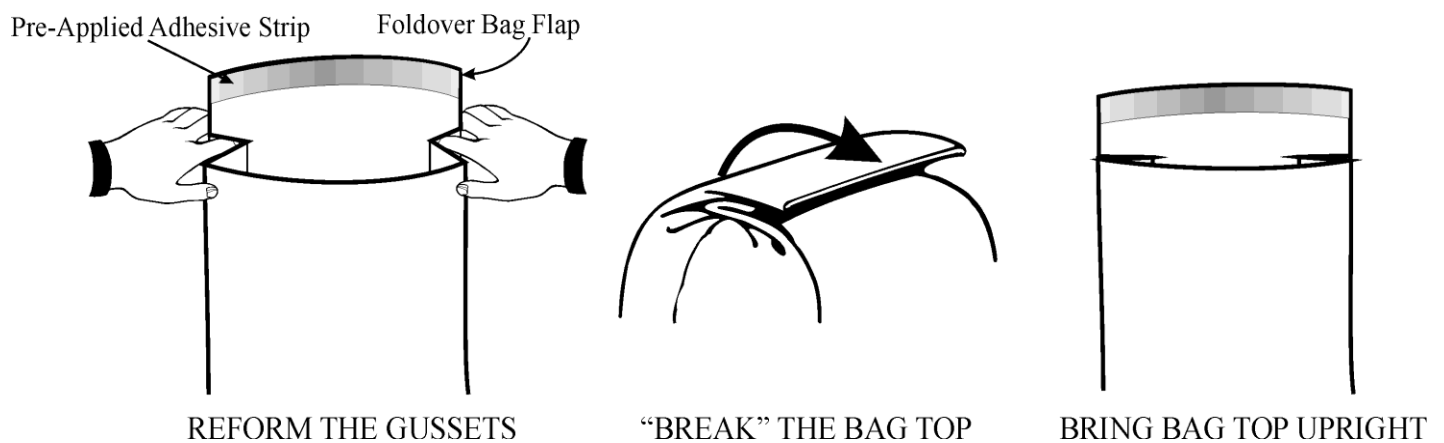

Figure 4-1: Reforming Bags before Passing through Pinch Bag Closer

After leaving the creaser, the bag is partially folded so that the top flap (with the pre-applied glue) is bent 90° or parallel with the floor (see Figure 4-2: Bag Entering Folder). The top surface of the hot air manifold has a series of holes for the hot air to exit the manifold and melt the glue on the flap of the bag. The folder holds the flap horizontally over the holes.

After the manifold, the folder continues bending the heated flap another 90° to complete the fold. The adhesive begins to make contact with the outer bag surface as the fold is completed and the bag enters the compression area of the machine. The wide compression belts press the flap firmly against the bag, to force the adhesive to penetrate the bag fibers. The completed fold and compression yield a sharp, clean fold with a strong bond.

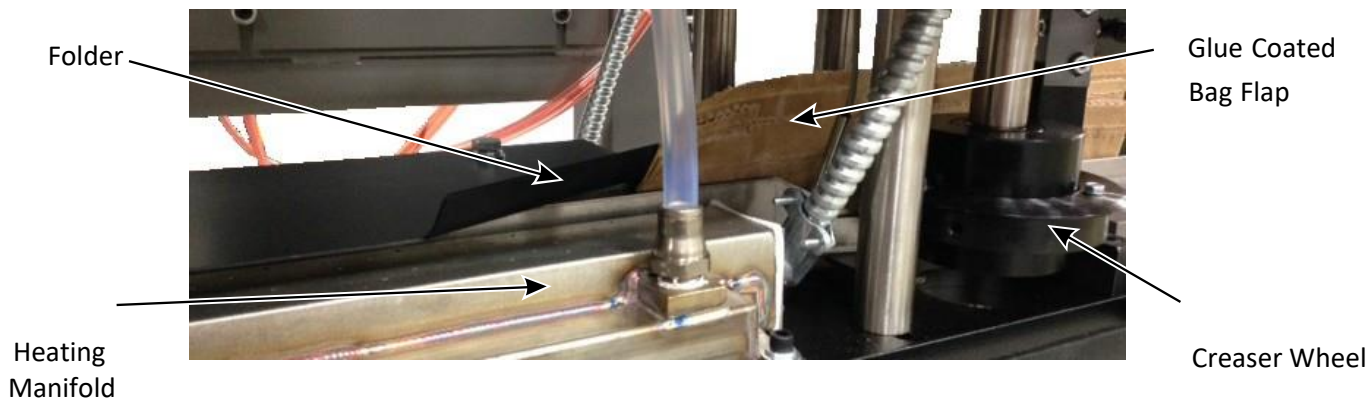

Figure 4-2: Bag Entering Folder

### 4.3. Startup Procedure



**WARNING: GRAB, PINCH, AND CRUSH HAZARDS!**  
**MAKE SURE THAT ALL GUARDS AND COVERS ARE IN PLACE BEFORE OPERATING THE MACHINE!**



**WARNING: GRAB, PINCH, AND CRUSH HAZARDS!**  
**OPERATORS MUST NOT WEAR LOOSE CLOTHING OR JEWELRY. LONG HAIR MUST BE PULLED BACK AND TIED TO AVOID GETTING CAUGHT IN ANY MOVING PARTS OF THE SYSTEM.**



**WARNING: EYE HAZARD!**  
**OPERATORS OF THIS MACHINE MUST WEAR EYE PROTECTION AT ALL TIMES WHEN WORKING AROUND THE MACHINE.**



**WARNING: BURN HAZARDS!**  
**OPERATORS OF THIS MACHINE MUST WEAR GLOVES WHEN WORKING AROUND THE HOT OR SHARP MACHINE SURFACES.**



**WARNING: CRUSH HAZARD!**  
**OPERATORS OF THIS MACHINE MUST WEAR FOOT PROTECTION AT ALL TIMES WHEN WORKING AROUND THE MACHINE.**

1. Check for any loose or missing fasteners or parts on the machine. Never operate the machine without all the parts attached and secured.
2. Connect clean, dry, and non-lubricated air to the pneumatics panel, using the quick disconnect fitting that is supplied with this unit. Push the safety control valve down to allow the compressed air to circulate through the machine. For most common bag types the flow meter can be set to read 400 SCFH (11,3 SCMH).
3. Turn the **HEATER ON/OFF** switch to the **OFF** position (see “HEATER ON/OFF Switch” on page 2- 5.).



- Turn the power Disconnect switch on the back of the electrical enclosure to the **ON** position (see Figure 4-3: Power Disconnect/Power Lock-out Switch). Make sure the 3-position motor mode Switch is turned to the **AUTO** position (see Figure 4-4: 3-Position Motor Mode Switch).

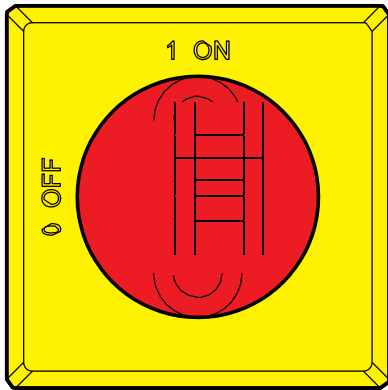

Figure 4-3: Power Disconnect/Power Lock-out Switch

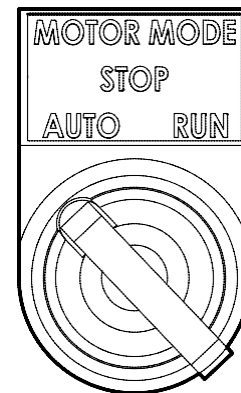

Figure 4-4: 3-Position Motor Mode Switch

- Push the green **START** button (see "START Button" on page 2- 5.) to start the machine. The button should stay illuminated if there are no system errors (see Figure 3-9: Speed Control).
- Push and hold both of the blue **PUSH TO CLOSE** buttons (see "STOP Button" on page 2- 5.) at the same time until front channel closes completely. Release the buttons and the front channel should stay closed. Check the belt direction to ensure that the machine is phased correctly.



**CAUTION: WHEN CLOSING THE FRONT CHANNEL, THE REAR BELTS MUST BE MOV- ING TO ALLOW THE DRIVE GEARS TO MESH SMOOTHLY. OCCASIONALLY, THERE MAY BE SOME NOISE WHEN THE GEARS FIRST COME TOGETHER.**

- Synchronize the machine with the conveyor speed using the **KEYPAD** (see "MISCELLANEOUS" on page 2- 6.). A tachometer can be used to measure the linear speed of the conveyor and the machine's carry through belts. Do not measure belt speed near turns in the belt.
- Turn **HEATER ON/OFF** switch to the **ON** position (see "HEATER ON/OFF Switch" on page 2- 5.). Set the temperature controller to the desired set point (see Figure 3-12: Displaying the Set Point). For most common bag types the initial setting should be about 450°F (232°C). Allow a minimum of 15-20 minutes for the machine to warm up. Use the "Trial Run / Bag Closure" technique mentioned below and adjust the temperature as necessary to get a good quality bag seal.
- Push either the **STOP** button (see "STOP Button" on page 2- 5.) or one of the **EMERGENCY STOP** buttons (see "EMERGENCY STOP Button" on page 2- 4.) at any time to open the front channel. Pushing the STOP button will open the front channel and keep the heaters on. The **EMERGENCY STOP** button will open the front (swing) channel, turn the electrical system and heaters off and leave the air flowing through the manifold.



**WARNING: NEVER TURN THE AIR SUPPLY OFF WHILE THE HEATERS ARE STILL HOT. ALWAYS LET THE HEATERS COMPLETELY COOL BEFORE TURNING THE AIR SUPPLY OFF.**



## 4.4. Trial Run and Bag Closure Test

The following procedure is a practical way to check the quality of bag closure while making the initial set up. Using an empty bag, seal it in the machine, allow it to cool and then examine it.

1. Cut the entire bag top off about six inches (152mm) down from the top of the fold. This will allow you to examine the closure from the inside of the bag top.
2. Cut the gusseted side panels away.
3. Open the cutaway panel. Stress the bonded area between your hands by pulling and "popping" the seal.
4. Peel the glue joint. A good bond will require some strength to peel apart the closure. Most importantly, bag fibers should be found embedded in the glue, along the entire length of the seal. Shiny surfaces will indicate a lack of adhesion to the bag. A bad bond will snap open and will be seen as a shiny surface along the glue strip, without paper fiber. This is due to incorrect heating or insufficient compression of the closure.

## 4.5. Shutdown Procedure

1. Turn the **HEATER ON/OFF** switch to **OFF**. Let the machine cool until the temperature is about 100°F (38°C) before turning the electrical and pneumatic supplies off. Not allowing the manifold to cool completely will shorten the life of the heaters and cause damage to the pneumatic hoses.



**WARNING: NEVER TURN THE AIR SUPPLY OFF WHILE THE HEATERS ARE STILL HOT.**

**ALWAYS LET THE HEATERS COMPLETELY COOL BEFORE TURNING THE AIR SUPPLY OFF.**

2. Push the **STOP** or **EMERGENCY STOP** switch. The swing channel will rotate up (open) and all belts will stop. The air will continue to flow through the hot air manifold.
3. Turn off the main disconnect switch on the door of the main electrical enclosure. Keep the switch off and locked out when not in use.
4. Push the pneumatic safety control valve up to the **OFF** position and disconnect the air supply by releasing the quick disconnect. This allows stored energy to be released from the unit.
5. Remove all paper scraps, debris and glue from the machine.



## 5. ADJUSTMENTS AND PART REPLACEMENTS

### 5.1. Adjustment Procedures

#### 5.1.1. CARRY THROUGH BELTS

The carry through belts are responsible for grasping the bag top at the infeed and guiding it through the system to be heated, folded and sealed closed. If the belts are not synchronized or are worn, they will not effectively control the bag top. The following sections will describe proper settings for the belts, as well as how to maintain and replace them.

##### 5.1.1.1. Carry Through Belt Plate Pressure

The carry through belts must grasp the bag top so that the bag cannot be removed from the belt without considerable effort. The belts are set at the factory for most common bag types. If bag samples were sent at the time the machine was ordered, then the belts are set for their characteristics.

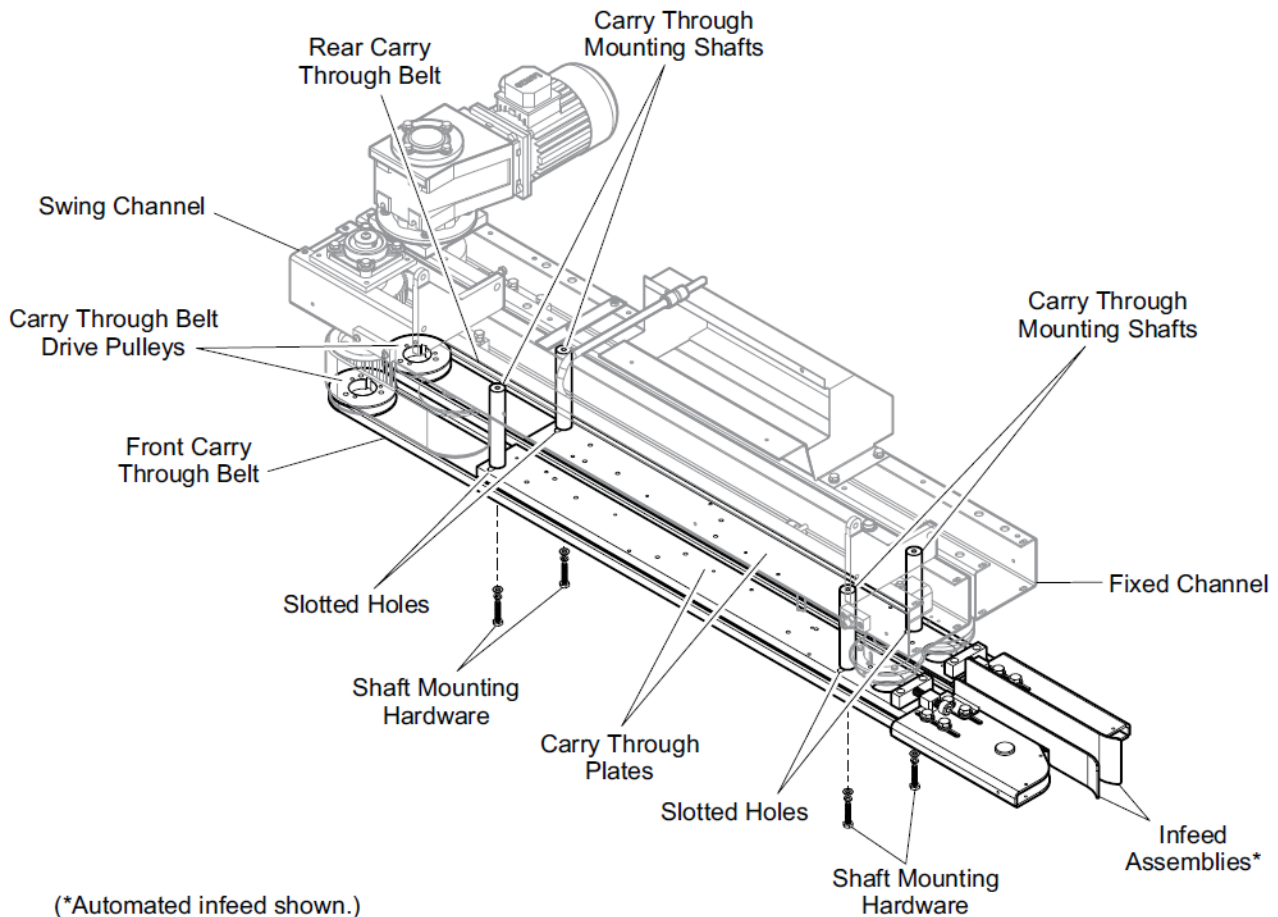

Figure 5-1: Carry Through Belt Plates



The pressure between the belts is determined by the placement of the carry through belt plates, located under the channels (see Figure 5-1: Carry Through Belt Plates). They are attached to the channels by carry through mounting shafts. The holes for the bolts holding the plates to the supports are slotted to allow the plates to move towards or away from the sealing centerline of the machine.

If the pressure between the belts must be adjusted, then follow these steps:



**WARNING: BE VERY CAREFUL WHEN WORKING ON THE MACHINE WHEN THE COVERS AND SHROUDS ARE REMOVED. FAILURE TO DO SO COULD RESULT IN SERIOUS INJURY!**



**WARNING: TURN OFF AND LOCK OUT THE ELECTRICAL AND PNEUMATIC SYSTEMS BEFORE REMOVING THE SHROUDS! FAILURE TO DO SO COULD RESULT IN SERIOUS INJURY!**

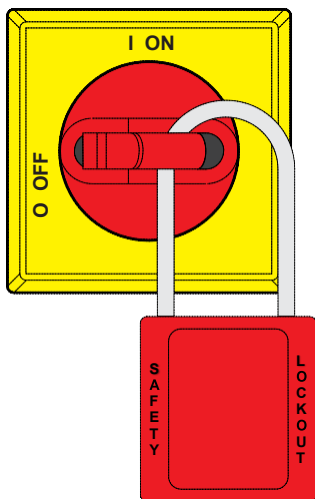

**Figure 5-2: Power Disconnect/Power Lockout Switch in Locked Out Position**

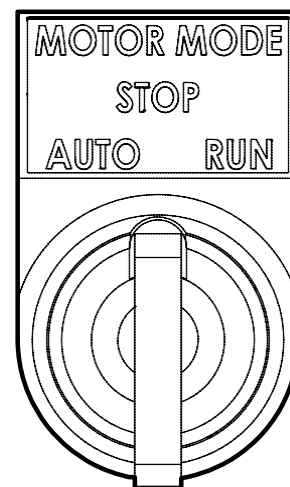

**Figure 5-3: Motor Mode Switch**

1. Remove the front (swing channel) and rear (fixed channel) shrouds to access the folder area.
2. Turn the Motor Mode Switch (see Figure 5-3: Motor Mode Switch) to the center **STOP** position. This will allow the pneumatic system to close the swing channel without the drive motor turning the belts.
3. Make sure the Heater control is **OFF**.
4. Turn the pneumatic and electric supplies **ON**.
5. Push the green **START** button and then push and hold both blue **CLOSE** buttons until the swing channel closes completely. The swing channel will stay closed and the drive motor will not be turning the belts.
6. Check the pressure between the carry through belts. Decide which plate needs to be moved or if both need to be adjusted. They should be evenly spaced on either side of the centerline from between the creaser assembly and compression rollers. The centerline should be centered between the channels.



7. Loosen the bolts that hold the plate to the carry through mounting shafts, but DO NOT remove them.
8. Gradually move the plate(s) to the desired position. Check to make sure that the pressure is consistently the same from one end of the plate to the other.
9. Tighten the bolts and check the pressure again.
10. Push the **STOP** button. Turn the Motor Enabled Switch to the **RUN** position.
11. Push the **START** button. The rear (fixed channel) belts will be activated.
12. Push and hold the **CLOSE** buttons until the swing channel closes completely. The swing channel will stay closed and the drive motor will be turning the belts.
13. Use a couple of empty sample test bags to ensure that the belts are properly grasping and holding the bag throughout the process in the machine. As they pass through the machine pull down on the bag to test how well the belts holds.
14. Use a couple of filled sample test bags to ensure that the belts are still operating correctly.
15. Turn the system completely **OFF**. install the shrouding and set the motor mode Switch to **AUTO**.

## 5.1.1.2. Carry Through Belt Tension

After normal usage, the carry through belts will become stretched and will need to be tightened. To test the belt, pull the belt away from the carry through plate, when the swing channel is open. If it deflects farther than  $\frac{3}{4}$  inch (19mm) from the plate, then the belt needs to be tightened. Loose belts may allow the bag top to be skewed as they pass between them. A belt with the proper tension will deflect (in the middle) between  $\frac{1}{2}$  to  $\frac{3}{4}$  inch (13 to 19 mm), when gently pulled away from the carry through plate. Do not over-tighten the belts. While inspecting the belts, check for fraying or gouges in the working surface of the belt. In this case the belt will need to be replaced.



**CAUTION: OVER-TIGHTENING THE CARRY THROUGH BELTS COULD CAUSE EXCESSIVE WEAR ON THE DRIVE PULLEY BEARINGS.**

To adjust the tension in the carry through belts, follow these steps:

1. Turn the Power Disconnect Switch to the **OFF** position (see Figure 4-3: Power Disconnect/Power Lock-out Switch) and lock out the electrical and pneumatic supplies.
2. Remove the fixed and swing channel shrouds.
3. Loosen the top and bottom plate mounting bolts on the infeed (see Figure 5-25: Infeed Idler Pulley Components).
4. Turn the tension bolt to adjust the tension in the carry through belt.
5. Once the desired tension is achieved, tighten the plate mounting bolts.
6. Install the fixed and swing channel shrouds.
7. Turn Motor Mode Switch to the **ON** position.
8. Test the system to make sure the belts are running smoothly and grasping the filled bags properly.



## 5.1.2. COMPRESSION BELTS

### 5.1.2.1. Determining the Correct Setting and Pressure between the Compression Belts

The amount of pressure required to make a strong complete closure, varies depending upon the characteristics of the bag. The type of adhesive on the flap and the thickness of the bag may require more or less pressure. The machine is designed to make adjusting the pressure quick and easy.

The belts wrap around the compression take-up roller, compression roller and drive sprocket. The teeth on the inside of the belt mesh with the teeth on the drive sprocket to keep the belt rotating at a constant rate. If the belt becomes too loose, the teeth could begin to slip over the drive sprocket, changing the timing of the belt. In the middle of the belt the compression rollers push towards the centerline between the channels, to force the hot glue and fold together, completing the seal. The compression rollers come together so that the fixed and swing channel compression belts are in contact. The rear roller must be set based on the gap between the channels and then the swing channel roller is adjusted to yield the desired pressure.

Once the machine is on and ready to run, feed test bags into the machine. Carefully inspect the folded portion of the bag top after they have been sealed. A proper fold and seal will have a relatively flat and even fold (see Figure 5-4: Fold and Seal Comparison). There should not be excessive amounts of wrinkles on the flap. When the bag has cooled and the seal is pulled apart, the adhesive should be bonding completely across the full length and width of the seal. There are two types of wrinkles that can appear to suggest an adjustment is needed. Wrinkles that are present, but NOT pressed flat, indicate that the pressure between the belts is too small and needs to be increased by bring the rollers closer together. The second type of wrinkle is large and pressed flat into the flap. This flat wrinkle indicates that the pressure is too large and needs to be reduced.

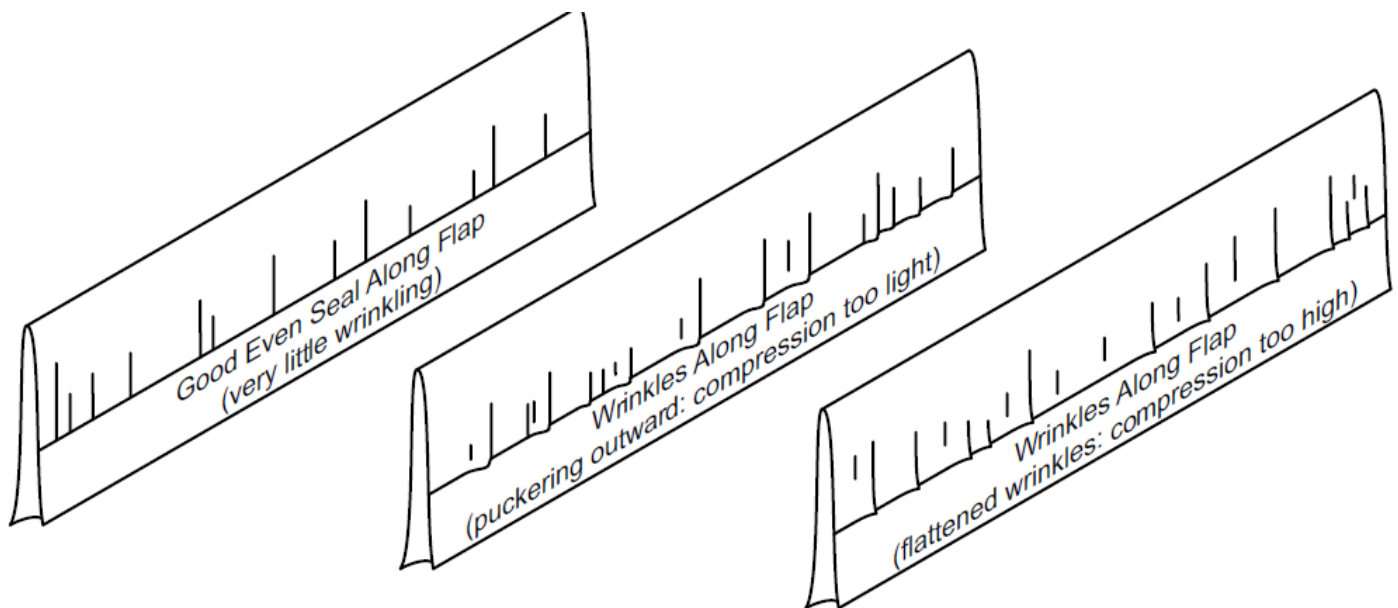

Figure 5-4: Fold and Seal Comparison



### 5.1.2.2. Compression Belt Pressure

The pressure between the belts is set based on the thickness of the bags being sealed. Generally, the thick bags only require that the belts come gently into contact. The thinner bags need to have a greater pressure between the belts. The best method for setting the compression between the rollers is by testing. To set the compression between the belts, follow these steps:

#### 5.1.2.2.1. REAR COMPRESSION ROLLER (FIXED CHANNEL)

The rear compression roller should be set before adjustments are made to the front compression roller. Generally, once the rear compression roller is set, it should not need to be adjusted, except after the belt has become worn or replaced. The ideal placement of the rear compression roller places the working surface of the compression belt directly beneath the centerline between the two channels, when the swing channel is in the closed position (see Figure 5-5:). However, if the roller has moved or needs to accommodate a different set up, follow these steps:

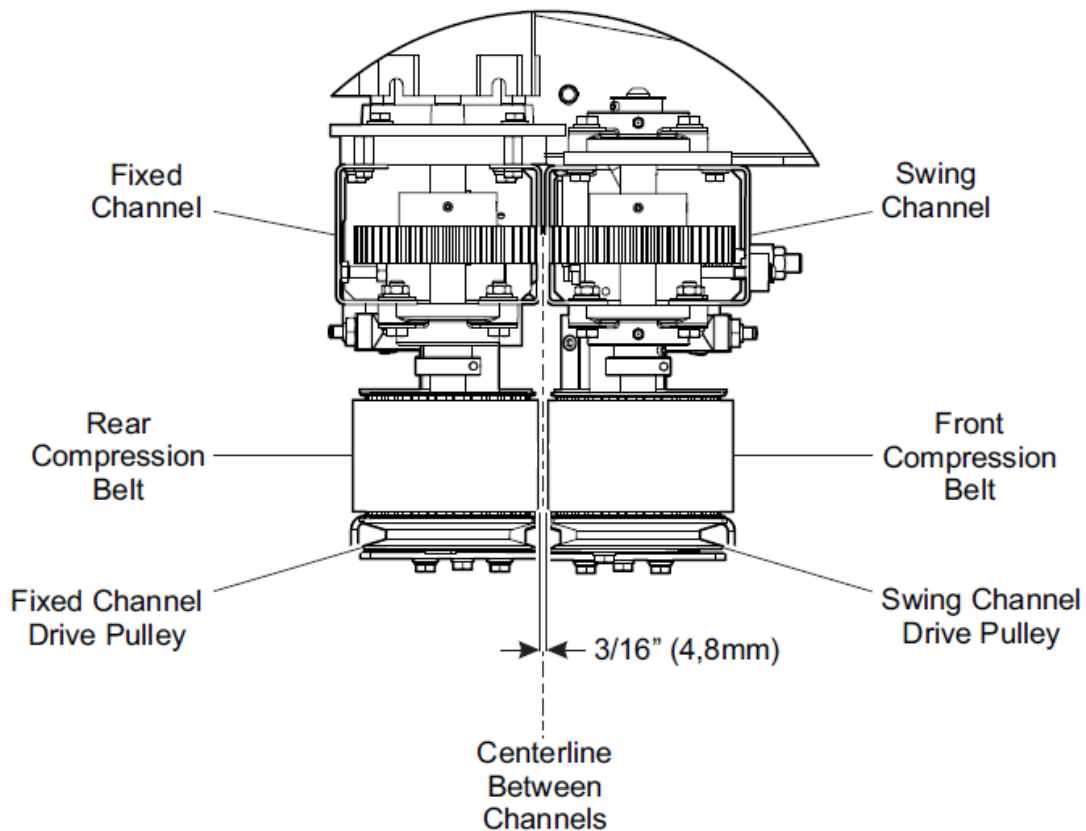

Figure 5-5: Ideal Compression Roller Placement



**WARNING: TURN OFF AND LOCK OUT THE MAIN ELECTRICAL AND PNEUMATIC SUPPLIES BEFORE ADJUSTING THE CARRY THROUGH BELT TENSION. FAILURE TO DO SO COULD RESULT IN SERIOUS INJURY!**

1. Remove the top left channel cover that is located near the drive motor. Remove the rear (fixed) and front (swing) channel shrouding.
2. The swing channel must be in the open position. When it is closed the gap formed between the channels is set at the factory to be 3/16 inches (4,8mm). The working surface of the rear compression belt should be directly beneath the middle of the gap or 3/32 inches (2,4mm) from the face of the channel (see Figure 5-5: Ideal Compression Roller Placement).



- The rear compression roller assembly is held in position by the ½ inch socket cap screw, which acts as the shaft for the roller (see Figure 5-6: Fixed Channel Compression Roller Components). To move the compression roller, loosen the screw just enough to allow the roller to move. Loosening the screw too much will allow the screw (shaft) to skew too much to accurately align the compression belt.

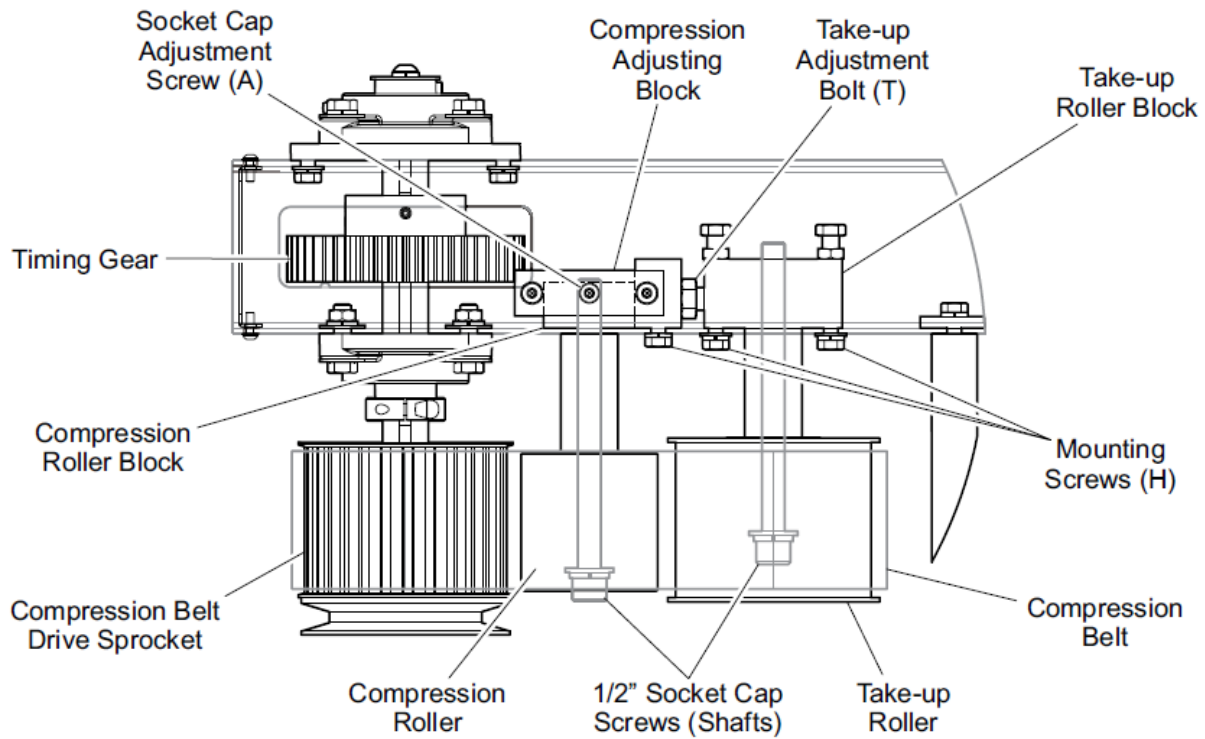

Figure 5-6: Fixed Channel Compression Roller Components

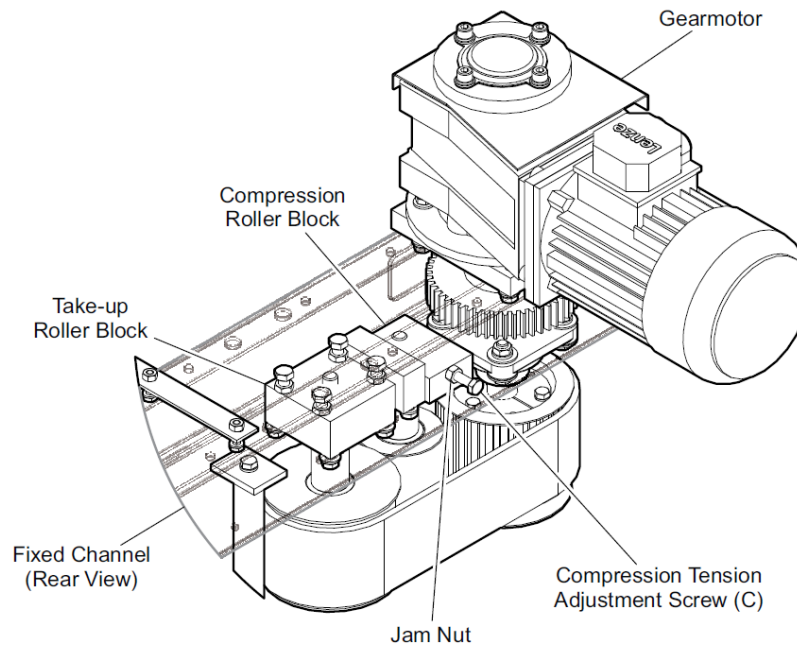
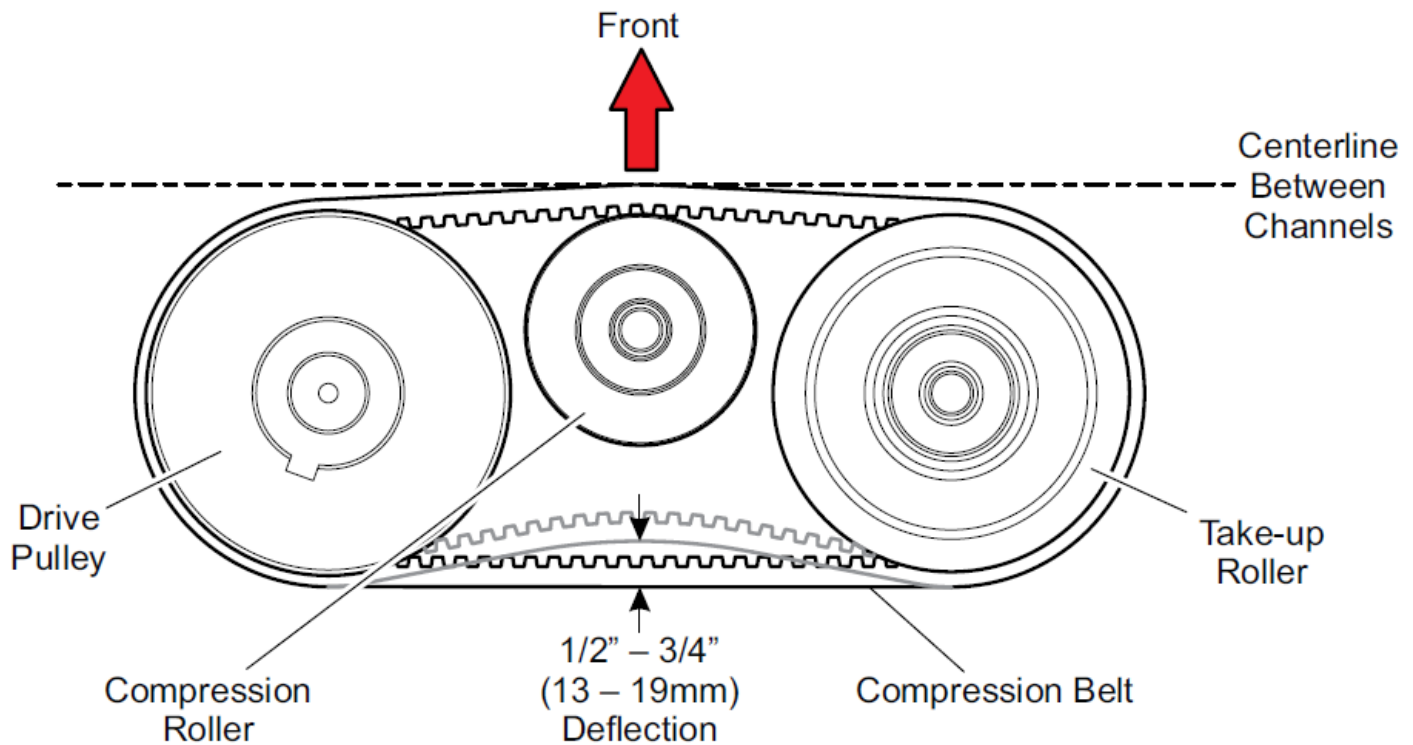

Figure 5-7: Compression Tension Adjustment Screw & Jam Nut



4. The rear (fixed channel) compression roller's position is controlled by its block, inside the channel. Between the block and the back wall of the fixed channel is a hex-head bolt (C) locked into position by a jam nut (see Figure 5-7:). By unlocking the jam nut and then turning this bolt so that it rotates into the block, the roller can be moved away from the centerline between the channels. As the bolt is rotated out of the block, the block is pushed towards the centerline between the channels. Once the rear compression belt is in position (see Figure 5-8:), lock the bolt into place with the jam nut.



**Figure 5-8: Correct Compression Roller Position**

5. Secure the compression assembly in place by tightening the ½ inch socket cap screw (shaft). Double check the alignment of the compression belt after the screw is tightened (see Figure 5-8: Correct Compression Roller Position).
6. Push in on the belt between the take-up roller and the drive sprocket. If the tension in the belt is correct, the belt should deflect about ½ to ¾ inch (13 - 19mm) (see Figure 5-8: Correct Compression Roller Position).
7. Turn **ON** the electrical and pneumatic supplies to the PBC. You may wish to test a few bags with the heaters off. Next test the compression roller settings with the heater on. Be sure to allow the manifold to heat up completely before testing begins. Follow the guidelines mentioned in the Quality Control section of this manual to determine a good seal.
8. Install the top cover over the channels and the rear shrouding.
9. If the rear compression belt is in the correct position, but adjustments need to be made to the compression force, then adjust the front compression roller as described in the next section.



### 5.1.2.2.2. FRONT COMPRESSION ROLLER (SWING CHANNEL)

Once the rear compression roller and belt have been positioned correctly, the front roller can be adjusted to alter the pressure between the belts. The front roller is adjusted in a similar fashion to the rear. Its block within the swing channel is moved towards and away from the centerline between the two channels by turning a screw in the side of the block. The socket cap adjustment screw passes through the front face of the swing channel and shrouding for easier access. The top shrouding above the compression assembly does not have to be removed to adjust the pressure once the rear compression roller has been set. To adjust the front compression roller and belt pressure, follow these steps:

1. For large adjustments to the front compression roller, the swing channel shrouding should be removed. This will allow access to the compression belt for testing its tension.



**WARNING: NEVER MAKE ADJUSTMENTS TO ANY ROLLERS OR SPROCKETS WHILE THE MACHINE'S BELTS ARE MOVING. DOING SO COULD RESULT IN SERIOUS INJURY!**

2. The front compression roller can be adjusted with the PBC machine on or off. If you choose to perform the adjustment with the system on you must turn the Motor Enable (keyed) Switch (see Figure 5-3: Motor Mode Switch) to the center **STOP** position. This will allow the swing channel to close without the drive motor turning the belts.
3. The front compression roller assembly is held in position by the ½ inch socket cap screw, which acts as the shaft for the roller. To move the compression roller, loosen the screw just enough to allow the block to move. Loosening the screw too much will allow the screw (shaft) to skew too much to accurately align the compression belt (see Figure 5-9: Swing Channel Compression Roller Components).

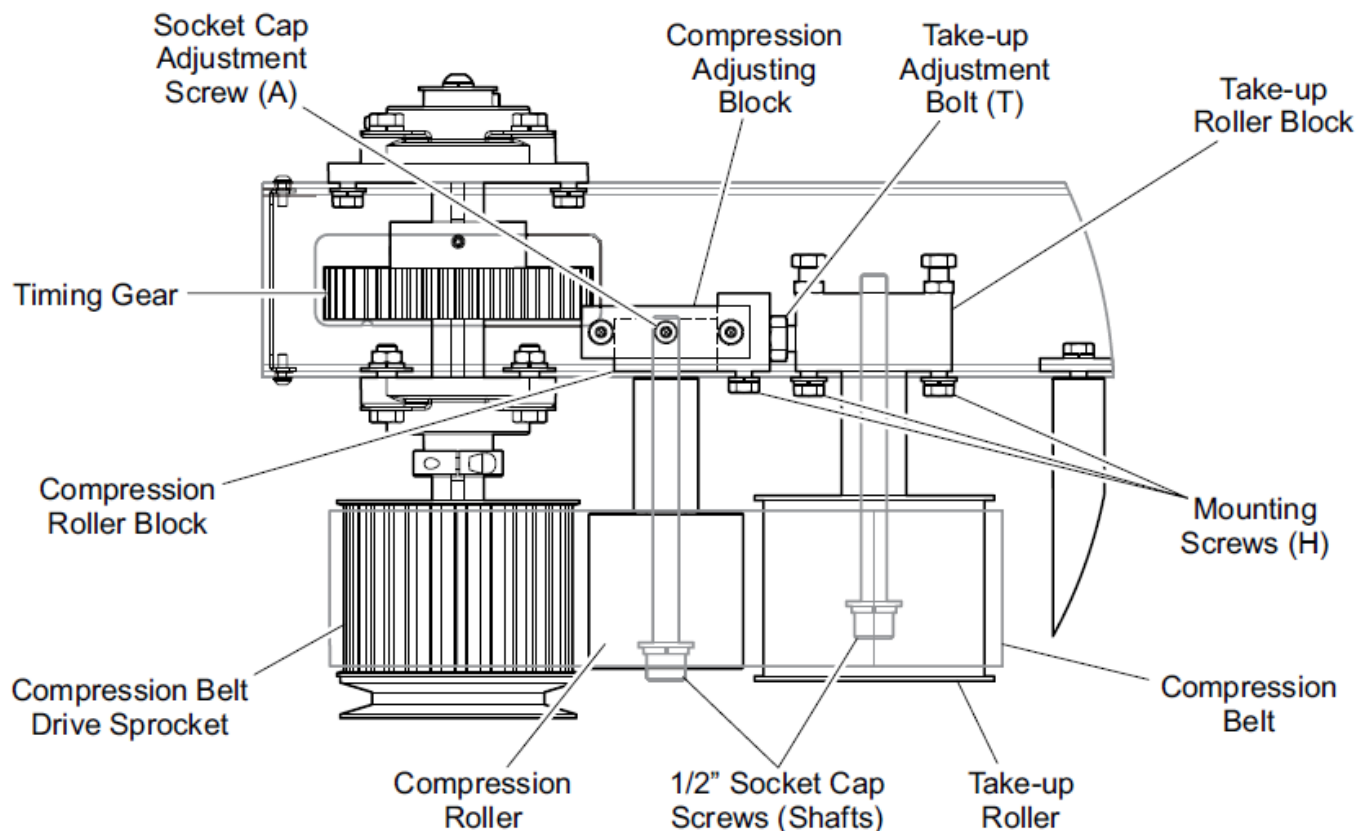
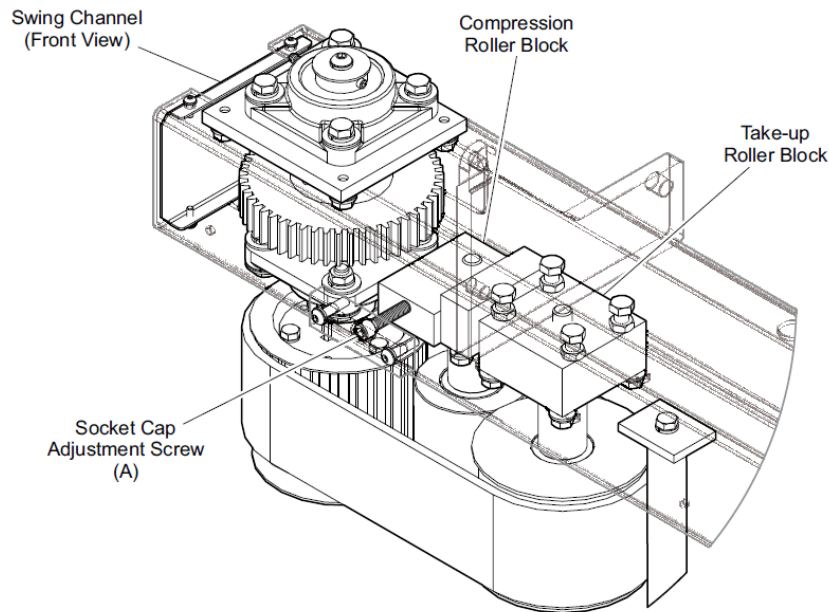

Figure 5-9: Swing Channel Compression Roller Components



4. The front (swing channel) compression roller's position is controlled by its block inside the channel. Between the block and the front wall of the swing channel is a socket cap screw (A), which passes through the channel wall and front shrouding (see Figure 5-9: Swing Channel Compression Roller Components). Turning the screw so that it rotates clockwise into the block, the roller is moved away from the centerline between the channels, which reduces the pressure between the belts. If the screw is rotated counterclockwise out of the block, the roller is pushed away from the front of the machine and causes the pressure between the belts to increase (see Figure 5-10: Front Compression Roller Adjustment).



**Figure 5-10: Front Compression Roller Adjustment**

5. Tighten the ½ inch screw socket cap screw (shaft) to lock the compression roller assembly in place.
6. Push in on the belt between the take-up roller and the drive sprocket. If the tension in the belt is correct, the belt should deflect about ½ to ¾ inch (13 - 19mm) (Figure 5-8: Correct Compression Roller Position). Install the swing channel shrouding, if it was removed.
7. Turn **ON** the pneumatic and electrical supplies to the PBC and turn the Motor Mode Switch to the **AUTO** position. Push the **START** button and then the **CLOSE** buttons until the swing channel stays in the down position.
8. You may wish to test a few bags with the heaters off. Next test the compression roller settings with the heater on. Be sure to allow the manifold to heat up completely before testing begins. Follow the guidelines mentioned in the Quality Control section of this manual to determine a good seal.

If the carry through belts are not holding the bag top well enough, but the compression is at the desired pressure, adjust the front carry through belt guide just enough to achieve the needed hold.



### 5.1.3. CREASER WHEEL

The creaser wheel of the PBC6000 is responsible for forming a crease in the bag top required to properly form the fold. The creaser assembly is divided into two main parts, one on the fixed channel and one on the swing channel. The swing channel portion forms the inside of the folded crease with a blade-type wheel. The fixed channel portion forms the top of the fold by using a grooved (die) roller that receives the creaser blade (see Figure 5-11: Creaser Wheel Components).

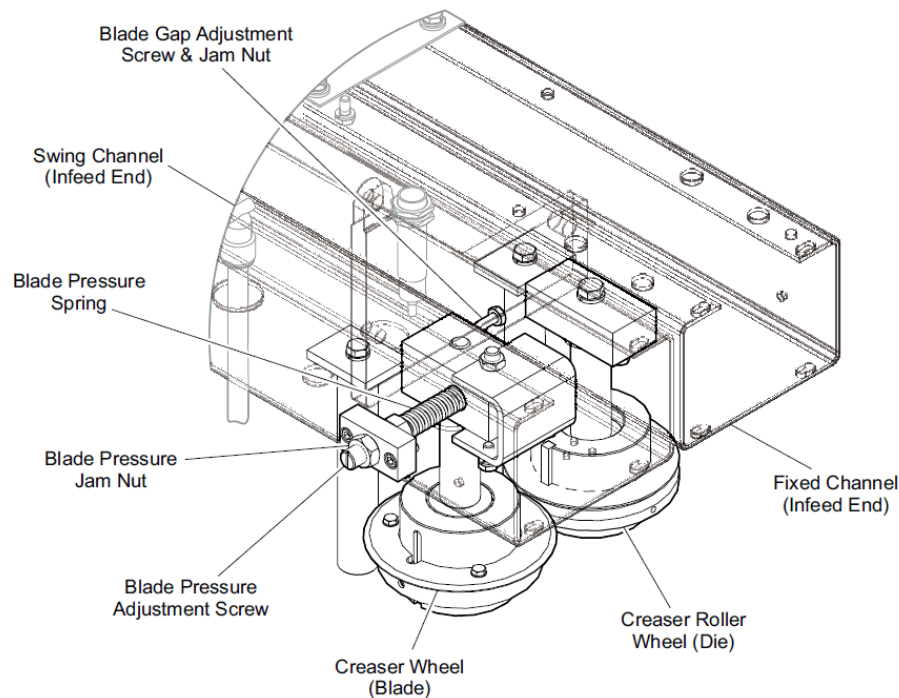

**Figure 5-11: Creaser Wheel Components**

The creaser assembly must create the crease at the correct height in relation to the folder and glue line. There is a specific sequence for adjusting the setting for the creaser.

- A. The creaser roller wheel (die) is aligned with the carry through belts.
- B. The creaser roller is set to the correct height in relation to the folder.
- C. The creaser blade (front) is adjusted to the correct height based on the roller wheel (die).
- D. The gap between the creaser blade and the groove of the roller wheel (die) is set.
- E. The pressure between the blade and die is determined and set.
- F. For the manual infeed, the bag guide is adjusted to introduce the bag's glue line to the machine at the correct height. For automated infeeds, the machine height may need to be adjusted to feed the glue line in at the correct height.

Before making any adjustments to the creaser area:

1. Turn **OFF** and lock out the electrical and pneumatic supplies to the PBC.
2. Remove the swing channel shrouding. The adjustment can be made without the fixed channel shrouding being removed.



3. Turn the Motor Enable (keyed) Switch (see Figure 5-3: Motor Mode Switch) to the center **STOP** position. This will allow the swing channel to close without the drive motor turning the belts. The swing channel must be engaged to properly set the creaser components.

### 5.1.3.1. Creaser Roller Wheel (die) Horizontal Adjustment

The carry through belts determine the centerline of travel for the bag passing through the system. The creaser hub face in the fixed channel must be centered directly above the centerline between the carry through belts. If the hub needs to be moved, follow these steps:

1. Loosen the two bolts, (J) holding the block to the channel (see Figure 5-12: Creaser Roller Wheel (Die) Block Hardware). Do not remove the bolts, (J).

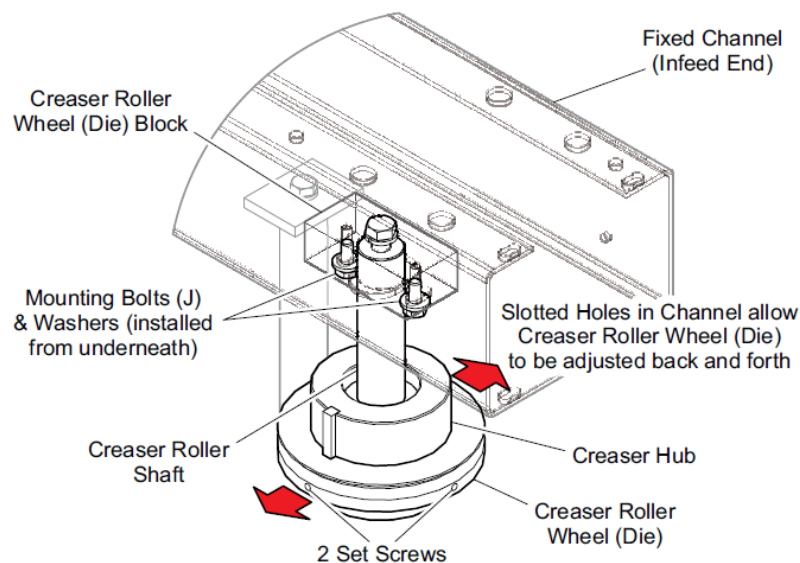
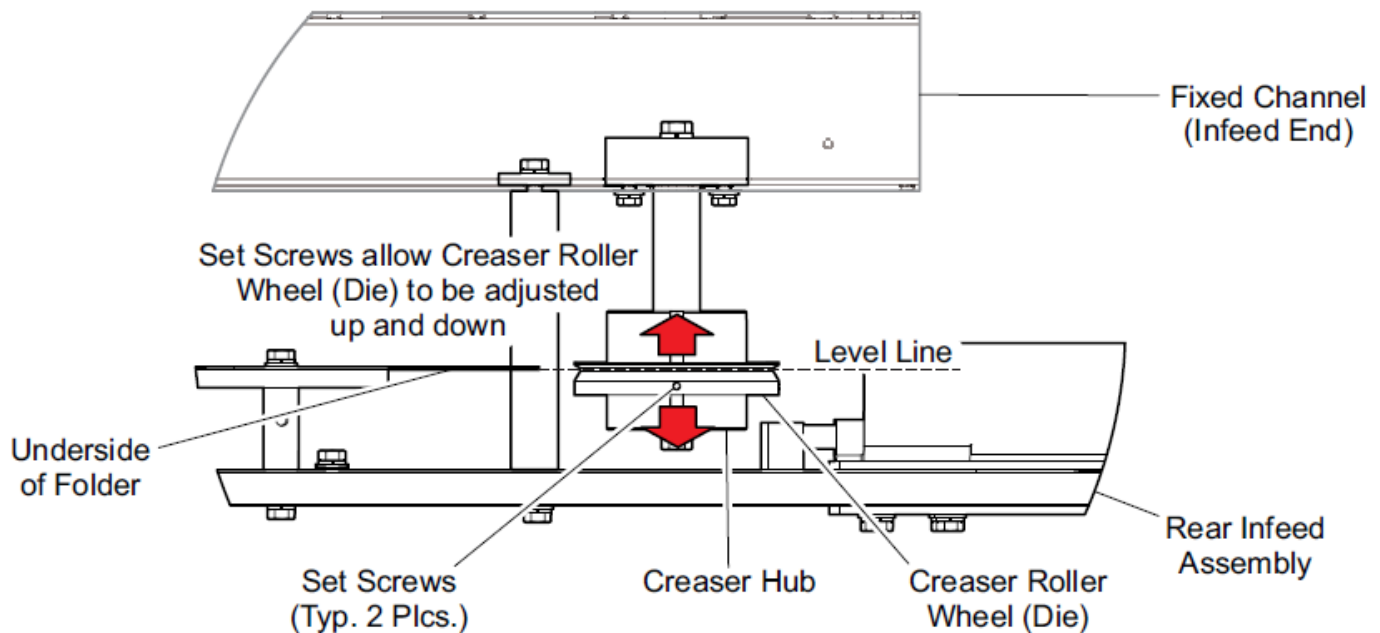

Figure 5-12: Creaser Roller Wheel (Die) Block Hardware

2. Insert a thin piece of metal between the carry through belts, below the hub of the creaser roller wheel.
3. Use the flat piece of metal to line the outer vertical surface of the hub with the centerline between the carry through belts. Move the assembly to the proper alignment.
4. Hold the assembly in position and tighten the bolts, (J) to hold the block in place. Turn the hub and make sure the hub surface aligns with the centerline completely. Also make sure that the wheel is directly behind the blade assembly. A line from the blade shaft to the die shaft must be perpendicular to the channel front face.

### 5.1.3.2. Creaser Roller Wheel (Die) Vertical Adjustment

The crease of the bag top must enter the folder at the correct height after exiting the creaser assembly. The creaser die groove must be centered across from the underside of the folder (see Figure 5-13: Creaser Roller Wheel Vertical Position). If the height of the creaser die needs to be adjusted continue to follow these steps:



**Figure 5-13: Creaser Roller Wheel Vertical Position**

1. Loosen the two set screws that hold the creaser roller wheel (die) to the creaser hub (see Figure 5- 12: Creaser Roller Wheel (Die) Block Hardware and Figure 5-13: Creaser Roller Wheel Vertical Position).
2. Line the middle of the die creaser groove with the underside of the folder.
3. Begin to tighten the set screws enough to hold the wheel in place.
4. Turn the wheel to make sure that the entire wheel is level and not skewed.
5. Tighten the set screws after the wheel has been aligned.

### **5.1.3.3. Swing Channel Creaser Blade Height**

The fold on a bag is properly formed when the blade is directly across from the horizontal groove in the die (creaser roller wheel). If the blade is too high or low, the fold will not be completely made. The blade must break the fibers in the bag material to form a good fold. The blade is attached to the creaser wheel (swing channel) by three bolts. To adjust the height of the blade, the wheel must be adjusted. If the blade height needs to be adjusted, continue to follow these steps:

1. Loosen the two set screws that hold the creaser wheel-blade assembly to the hub (see Figure 5-14: Swing Channel Creaser Blade Vertical Adjustment).
2. Move the assembly until the blade edge is directly across from the center of the groove in the die.
3. Carefully hold the assembly in place while beginning to tighten the set screws.
4. Rotate the hub and check the blade to ensure all sides are centered across from the die groove. The blade must be level to consistently function.
5. When the blade is positioned correctly, tighten the set screws and rotate the assembly again to ensure that it is level all the way around.

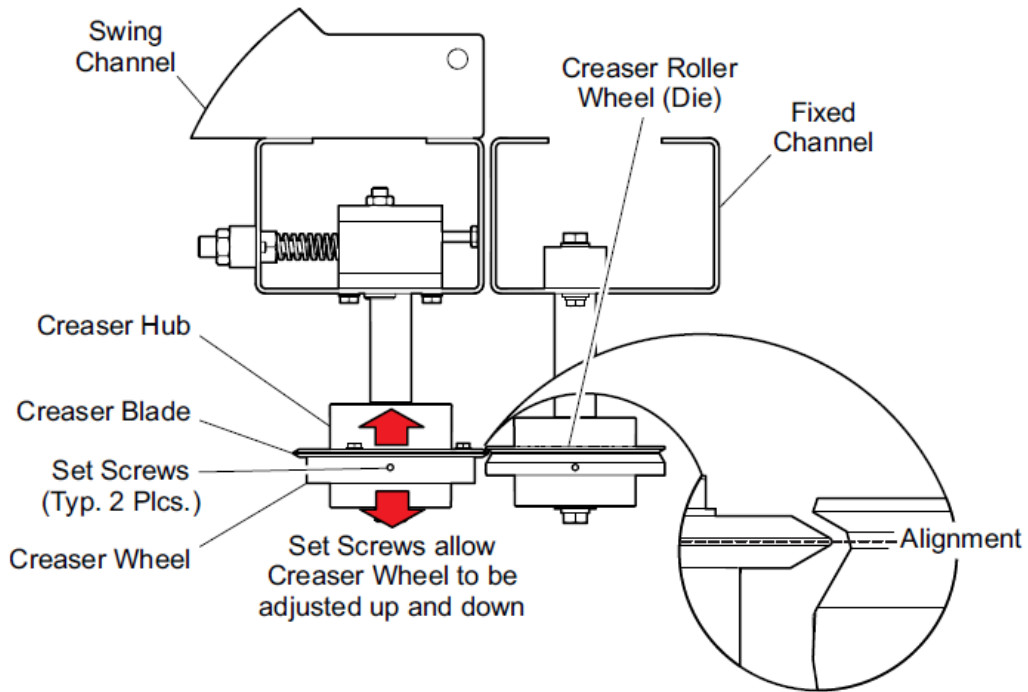

Figure 5-14: Swing Channel Creaser Blade Vertical Adjustment

#### 5.1.3.4. Blade Horizontal Gap

The gap between the blade and the die groove is determined by the type of bags being closed. The optimum range suggested for the gap is from 3/32 - 3/16 inch (2,4 - 4,8mm). Set the gap for the larger gap size for thicker bag materials and the smaller gap for the thinner materials. The gap can be easily and quickly changed. The horizontal location of the creaser blade is adjusted by a bolt in the block of the creaser blade assembly, located in the swing channel (see Figure 5-15: Creaser Blade Horizontal Adjustment). To adjust the gap setting, continue to follow these steps:

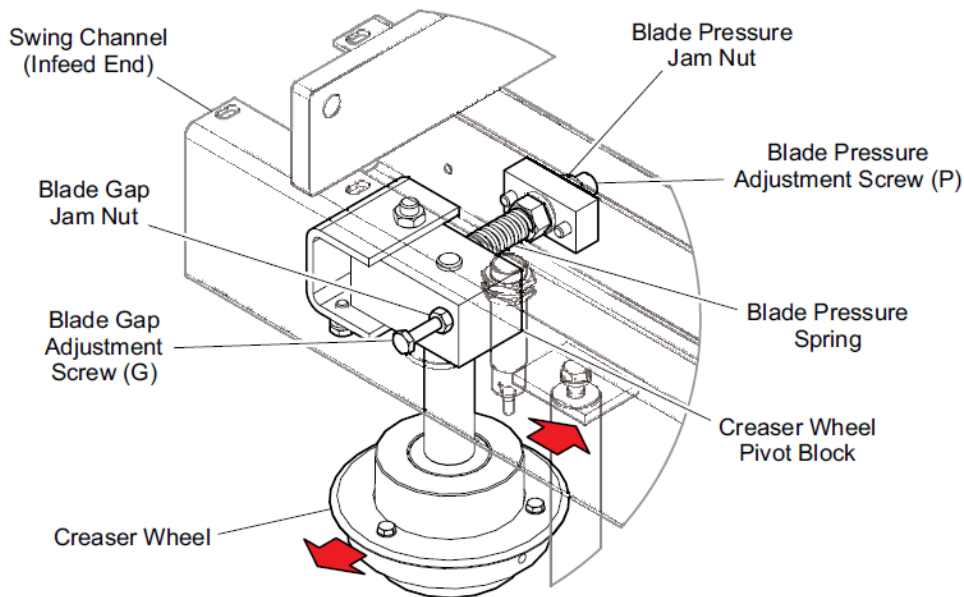

Figure 5-15: Creaser Blade Horizontal Adjustment



1. Remove the top cover (guard) in the center of the machine, which surrounds the base of the electrical control box.
2. Loosen the Blade Gap Jam Nut (see Figure 5-15: Creaser Blade Horizontal Adjustment).
3. Turn the Blade Gap Adjustment Screw, (G) in or out of the block to decrease or increase the gap size, respectively. The blade must never come into contact with the die.
4. Once the desired gap is achieved, lock the adjustment screw, (G) into position with the jam nut.

### 5.1.3.5. Creaser Blade Pressure

As a bag enters the creaser assembly, the creaser blade assembly is free to move, to allow for varying thicknesses in each bag's profile. Near the leading and trailing edges of the bags, the gussets double the thickness of the bag and yet still need to be effectively creased, folded and sealed. The blade assembly is designed with a compression spring to ensure a steady pressure is applied to the blade and to allow the blade to adjust to changing bag contours.

The blade pressure must be high enough to break the fibers in the bag material, but low enough to prevent problems in the folding and sealing process. It has been observed that for thinner bag materials, the pressure can be set at a lower pressure. For thicker or more rigid materials the pressure will have to be set to a higher pressure. If the pressure is set too high, the bag may jam while entering the creaser wheels, the flap may be excessively wrinkled or the crease line will be crescent in shape, rather than a straight line. Adjusting the pressure of the blade is a quick and easy procedure. To adjust the pressure, continue to follow these steps:



**CAUTION: WHEN MAKING ADJUSTMENTS TO THE BLADE PRESSURE, TURN THE ADJUSTMENT SCREW IN HALF-TURN INCREMENTS AT A TIME.**

1. Loosen the jam nut on the Blade Pressure Adjustment Screw (P). The nut and screw can be seen on the front face of the swing channel (see Figure 5-15: Creaser Blade Horizontal Adjustment).
2. From the front of the machine, turn the screw, (P) clockwise to increase the pressure and counter-clockwise to reduce the pressure. This changes the compression in the spring. For most instances, the pressure needed for most common bag types can be produced within a couple of turns of the lightest settings of the adjustment screw (P).
3. Once the desired pressure is achieved, lock the screw in position with the jam nut.

After the heights and horizontal adjustments have been completed, the creaser section of the machine should be tested on empty test bags. If the settings are correct, the bag will enter the creaser region without jamming and the crease line formed by the blade should be fairly straight (see Figure 5-16: Correct Bag Height). Some bending will occur in the blade line due to the gussets on the ends of the bags. The flap will have a few wrinkles in the material, but not large enough to prevent a consistent seal. The bag should enter the folder smoothly without hanging up.

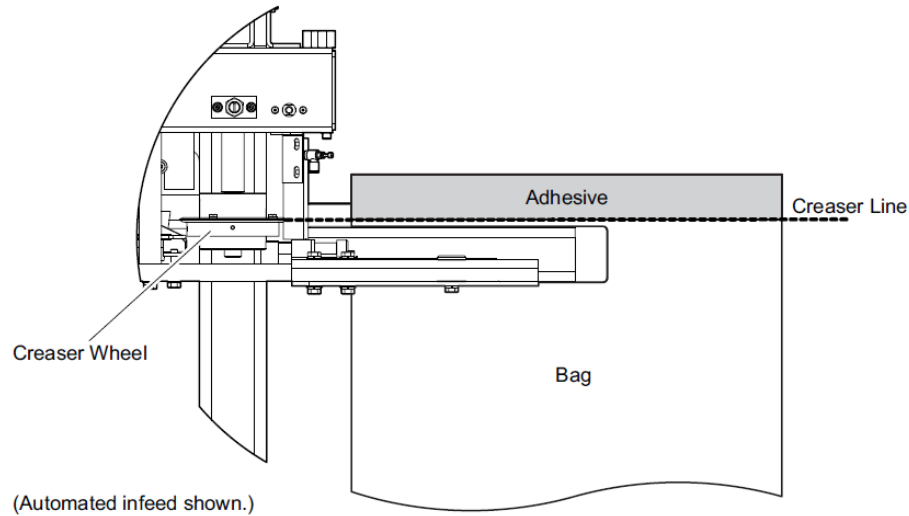

Figure 5-16: Correct Bag Height

#### 5.1.4. FOLDER AND GUIDES

The PBC6000 is equipped with a folder plate and bottom folder guide on the fixed channel and a hot air manifold guide on the swing channel. These components work together to gradually bend the bag flap at the crease line, expose the adhesive to the hot air manifold and then complete the fold before entering the compression assembly. If the folder and guides are not properly set, the bag flap will not make an attractive or effective closure.

This section of the manual is provided to act as a guide from which to start your adjustments. Each bag type has its own characteristics, which may require slight adjustments to a couple of components. If sample bags were sent to the factory at the time of the purchase, then the machine has been set for that specific bag type. If adjustments are required, generally the adjustments are slight and easily accomplished. Below you will find the instructions for setting the folders and guides for a general set up. From there the assembly can be fine tuned for specific applications.

##### 5.1.4.1. Folder and Bottom Folder Guide

1. Turn the Motor Enable (keyed) Switch (see Figure 5-3: Motor Mode Switch) to the center **STOP** position. This will allow the swing channel to close without the drive motor turning the belts. With the swing channel in the closed position, the folders and guides can be aligned correctly.
2. Remove the fixed and swing channel shrouds to access the folding components.
3. Place a stiff, thin, flat piece of metal between the carry through belts, to properly align the lower folder.
4. The bottom folder guide provides a surface for the rear of the bag to travel along, while the flap is heated and folded. The face of the bottom folder guide must be parallel to the face of the rear carry through belt and perpendicular to the top surface of the rear carry through plate (see Figure 5-17: Folder and Bottom Folder Guide Positions).

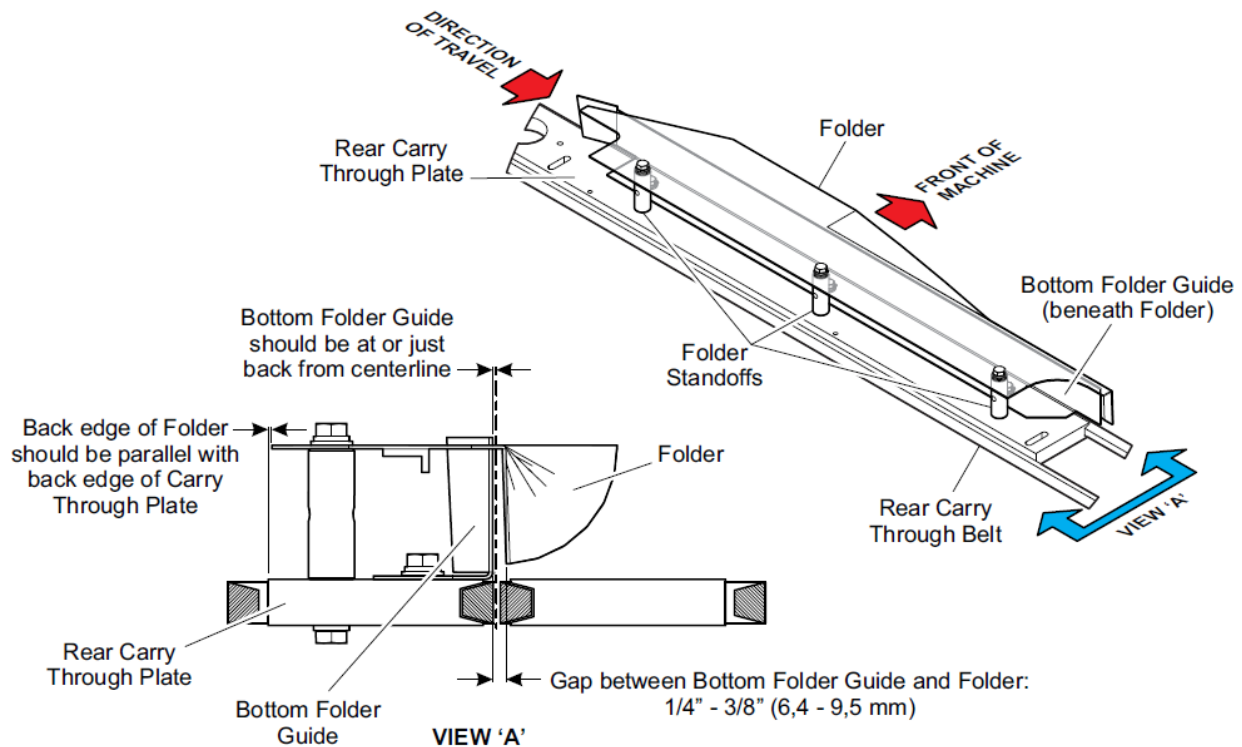

**Figure 5-17: Folder and Bottom Folder Guide Positions**

5. The folder can be adjusted from the rear of the machine after the bolts holding it to the standoffs have been loosened.
6. The folder does the actual bending of the flap. During this process the flap is held above the hot air manifold to melt the adhesive. For most bag types the trailing edges of the folder and bottom folder guide should have a gap between them of about ¼ to 3/8 inch (6,4 to 9,5 mm) (see Figure 5-17: Folder and Bottom Folder Guide Positions).
7. While holding the gap between the bottom folder guide and the folder, adjust the folder so that it is parallel with the back edge of the carry through plate. There are three bolts and standoffs that hold the upper folder in position. Once the bolts are loosened, the upper folder can be adjusted.

#### **5.1.4.2. Heater Manifold Guide**

Once the rear (fixed channel) folder and bottom folder guide have been set into position, the remaining "fine tuning" can be performed on the swing channel's manifold heater guide. The hot air manifold can also be adjusted horizontally. It is important that a gap is left between the hot air manifold and its guide. Left in contact or too close to each other, the guide will reach a high temperature, which can mar the surface of the bag, creating a build up of material on its surface.

The position of the manifold guide allows for the actual thickness of the bag top material. The guide must be aligned to be parallel with the carry through plate and the manifold top. Its top edge should rise above the hot air manifold's top by about ¼ inch (6,4mm) (see Figure 5-18: Heater Manifold Guide Positioning). The guide must be above the manifold to prevent the glue strip from coming into contact with the manifold surface. If the guide is not high enough over the manifold, the flap will come into contact with the manifold and the glue will begin clogging the holes in the manifold top. Obstructed holes prevent the hot air from exiting the manifold and will not allow the glue strip to completely heat.

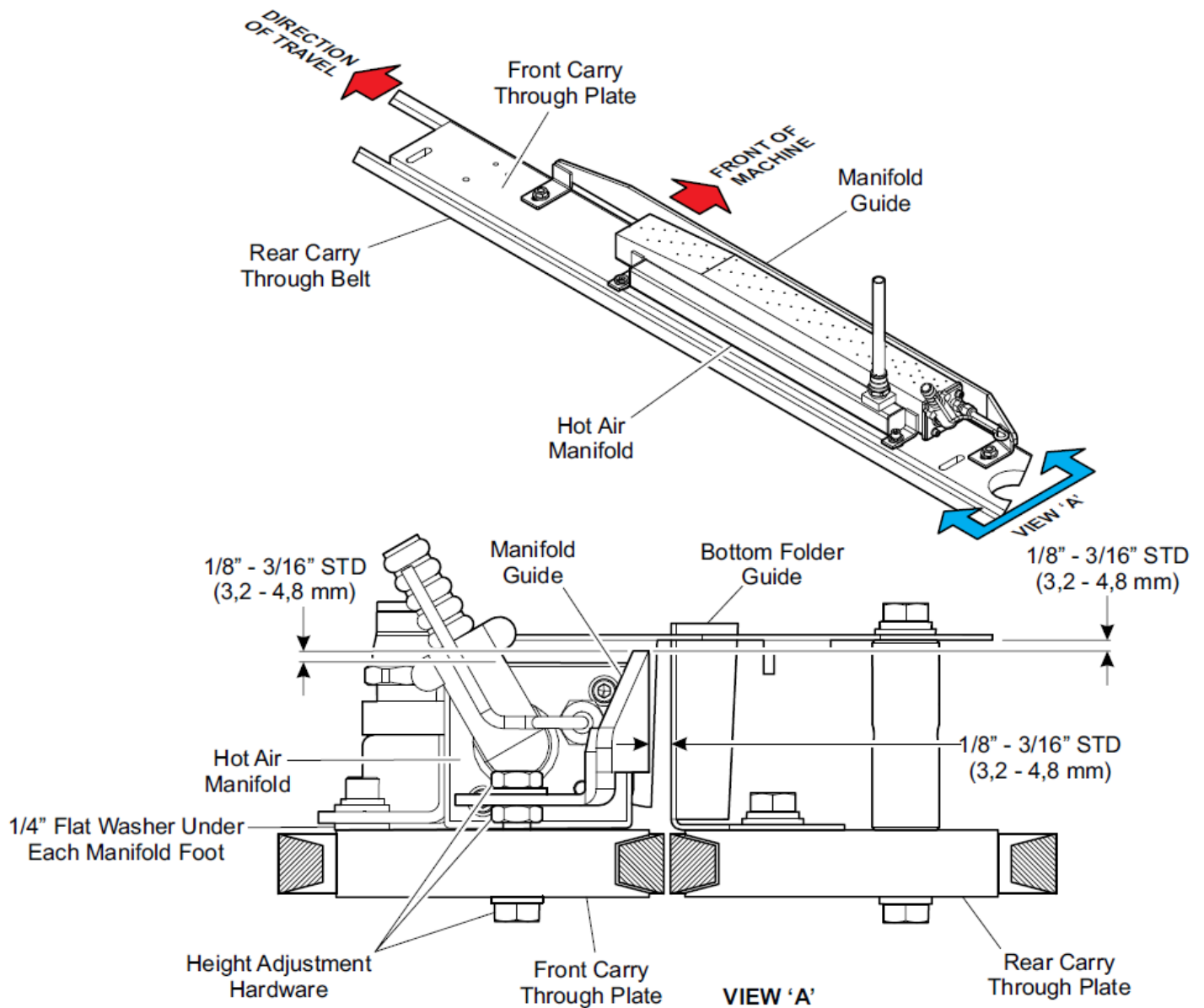

**Figure 5-18: Heater Manifold Guide Positioning**

1. Horizontally: To adjust the manifold guide loosen the two height adjustment bolts holding it to the carry through plate. The gap (directly above the centerline between the carry through belts) between the bottom folder guide and the manifold guide should be about 1/8"–3/16" (3,2–4,8mm). This gap is a standard setting and may need to be adjusted based on the bag thickness (see Figure 5-18: Heater Manifold Guide Positioning).
2. Vertically: To adjust the height of the guide, jam nuts are used with a bolt to secure the guide at the desired height. The top edge of the manifold guide should be about 1/8"–3/16" (3,2–4,8mm) above the top of the manifold and below the underside of the folder.
3. Once the guide is in place and aligned, secure it in position with the two bolts and nuts.



4. The hot air manifold must be placed in a position providing the maximum amount of hot air flow to the adhesive strip and flap. It is not only important to heat the glue, but also the bag material. The glue will always have difficulty penetrating a much colder bag material. The glue strip should be carried over the holes and not contact the guide. If the bag does come into contact with the manifold, raise the height of the guide. The hot air manifold is not to be raised or lowered. It is designed for horizontal adjustments only.
5. Install the fixed and swing channel shrouds.
6. Turn the Motor Enabled (keyed) Switch to the **AUTO** position.

### 5.1.4.3. Testing

1. Turn **ON** the electrical and pneumatic supplies to the machine. Leave the heaters turned off for the initial test runs.
2. Close the swing channel and feed a couple of sample bags into the machine. Carefully inspect the bag tops as they pass through the system. Check for interruptions, snags or irregularities in the folding.
3. Turn the heaters on and allow the machine time to completely warm up.
4. Feed sample test bags into the machine and check the quality of the closures. Also test filled bags through the machine. Use the Quality Control Guide of this manual to assist you in determining a good seal.

### 5.1.5. TEMPERATURECONTROLLER

The PBC6000 utilizes a temperature controller that has useful options and controls. The digital display is easily read and adjustable. To understand more available options, be sure to read the Instruction Manual found in the electrical enclosure. The instructions in this PBC manual will only summarize the more utilized functions for a technician and operator.

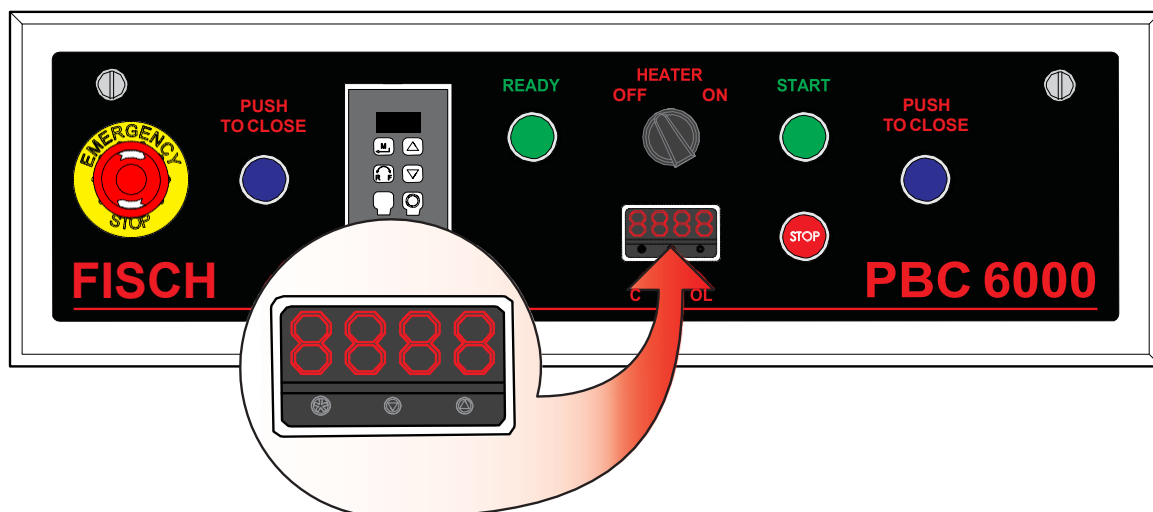

Figure 5-19: Temperature Controller



Within the heater manifold is a thermocouple, monitored by the heat controller. The controller on the front electrical control panel uses the information from the thermocouple to monitor and adjust the heater. To adjust the temperature to the heater, use the controller on the electrical control panel (see Figure 5-19: Temperature Controller).

### 5.1.5.1. Temperature Adjustment

1. To display the set point, push and hold in the \* button. The display (see Figure 5-19: Temperature Controller) will alternate between the set point temperature and the temperature scale (°C for Celsius and °F for Fahrenheit).
2. To change the set point, push and hold in the \* button and then press the ▲ or ▼ keys to increase or decrease the setting.
3. Release the buttons when done.



**CAUTION: ONLY MAKE SMALL INCREMENT CHANGES TO THE SET POINT UNTIL THE DESIRED CLOSURE IS ACHIEVED. BE SURE TO ALLOW FIVE TO TEN MINUTES FOR THE HEATERS TO REACH THEIR OPTIMUM LEVEL BEFORE SEALING BAGS IN THE PBC6000.**

#### START UP DISPLAY

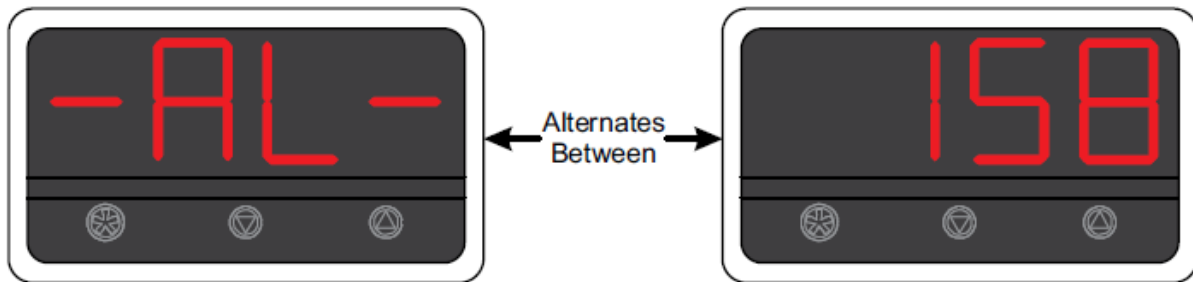

#### SET POINT DISPLAY

Press and hold the "\*" key.

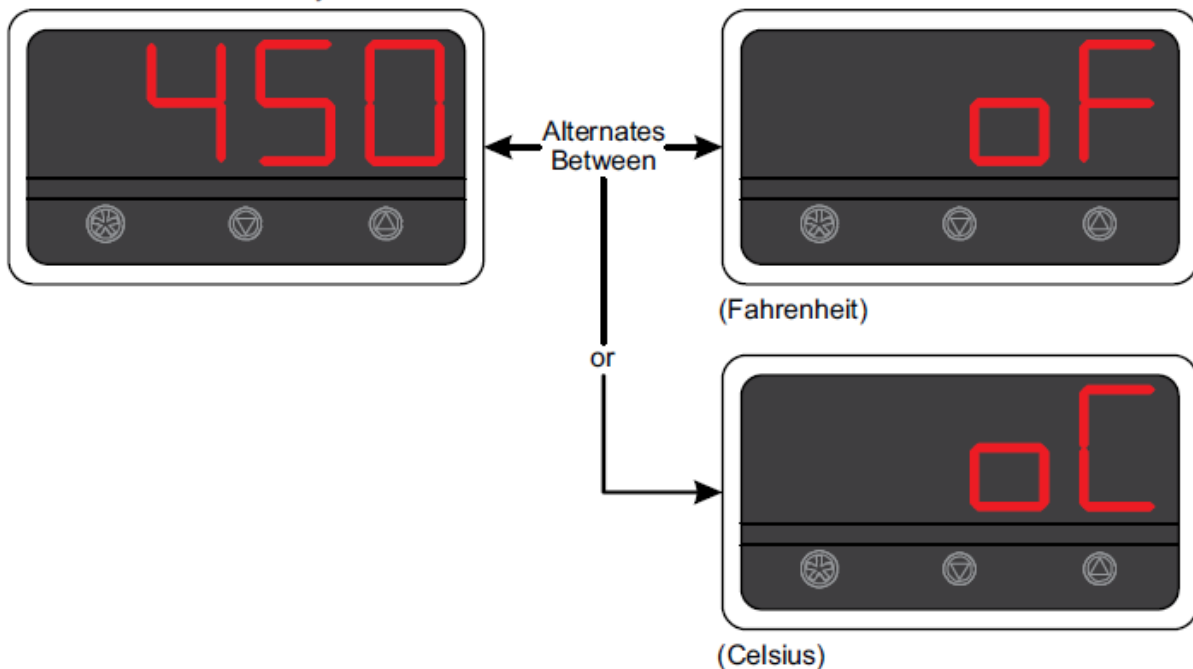



Further information on options, error messages and settings of the temperature controller can be found in the controller's Instruction Manual (in the electrical enclosure).

## 5.2. Replacement Procedures

### 5.2.1. COMPRESSION BELTS

After normal use the compression belts will show wear at the compression surface and on the inner teeth. Belts with significant gouges will not provide the needed pressure across the adhesive area. When it is determined that the belts need to be replaced, always replace both belts. If the belt needs to be replaced, follow these instructions:

1. Turn **OFF** and lock out the electrical and pneumatic supplies to the PBC.
2. Remove the front (swing channel) and rear (fixed channel) shrouds. Remove debris and dirt from the shrouds.
3. Remove the top cover shrouding that is above the compression assembly area (near the drive motor).
4. Loosen the ½ inch screw of the swing channel compression roller from the bottom of the machine enough to allow the block to be moved. Turn the socket cap adjustment screw (A) clockwise, to begin releasing the tension in the swing channel compression belt (see Figure 5-21:).

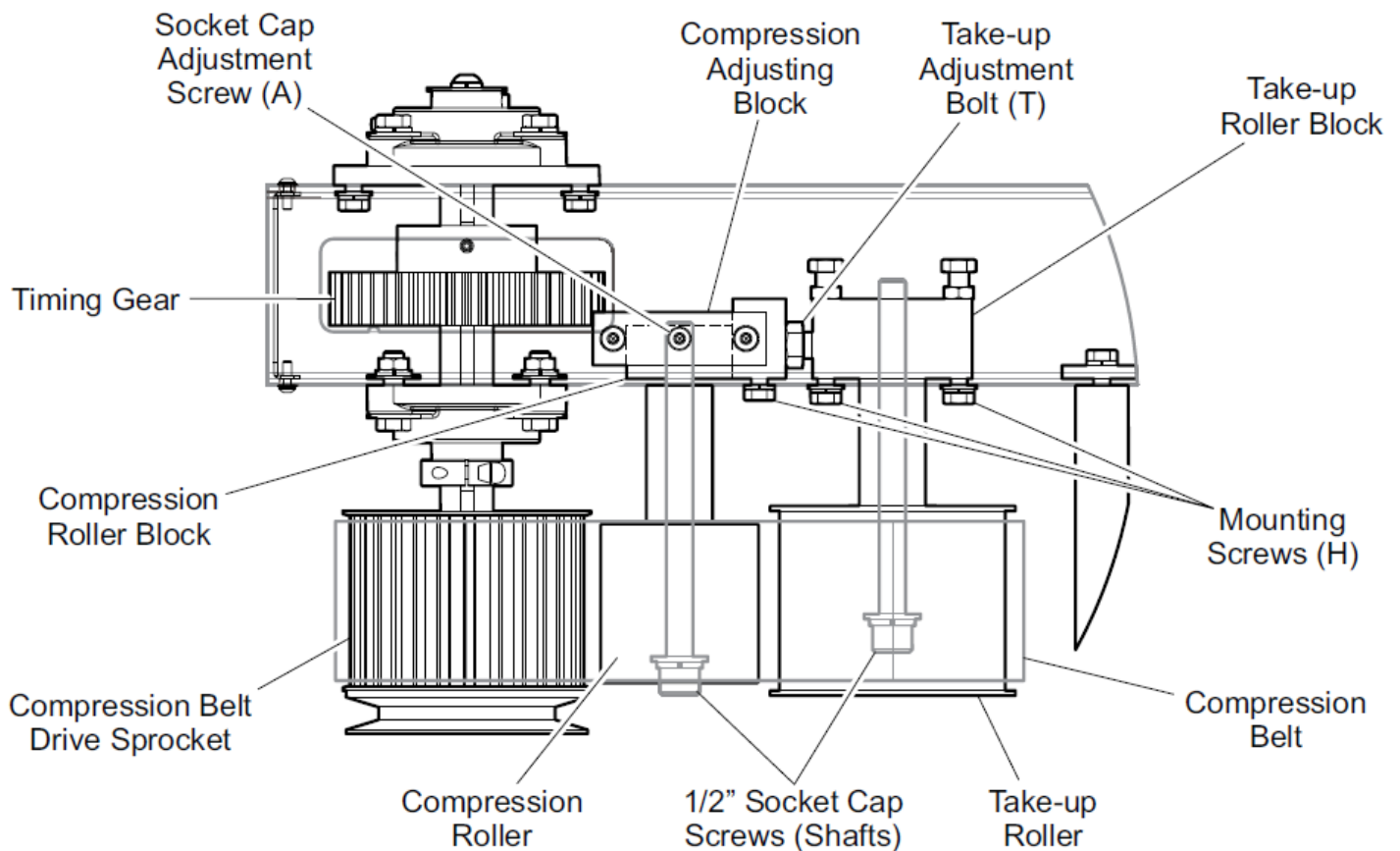
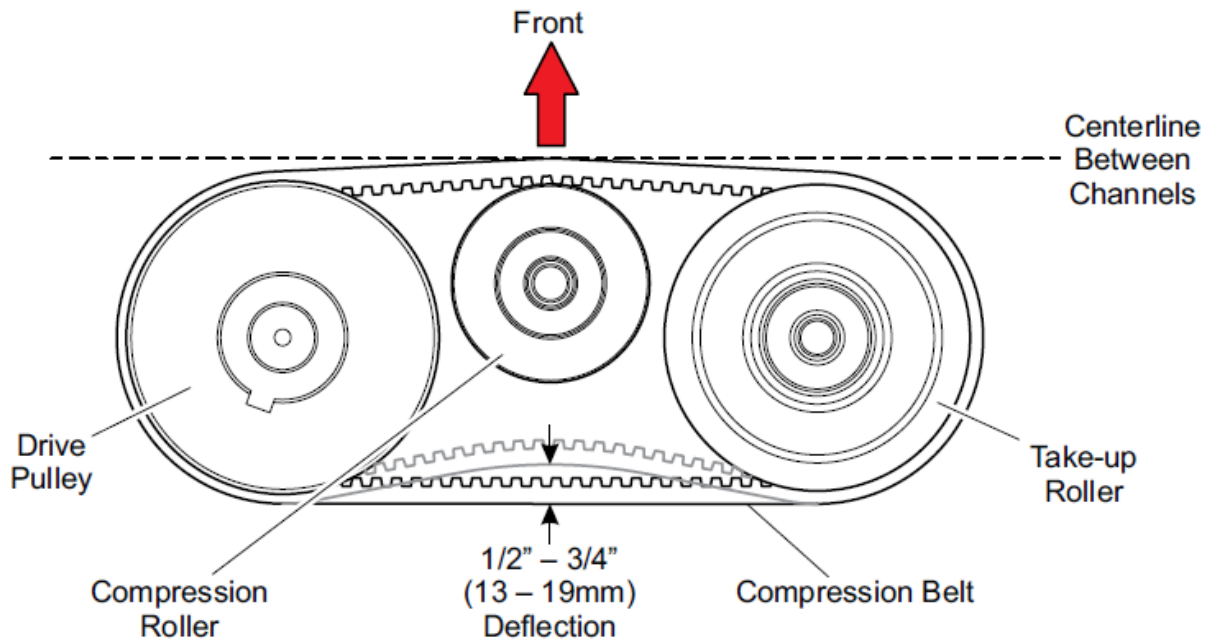

Figure 5-21: Front Compression Roller



5. Loosen the  $\frac{1}{2}$  inch screw of the fixed channel compression roller from the bottom of the machine enough to allow the block to be moved. The rear (fixed channel) compression roller is moved by unlocking the jam nut and turning the (rear compression block) adjustment screw (C) into the block. This action will begin to release the tension in the rear compression belt (see Figure 5-7: Compression Tension Adjustment Screw & Jam Nut and Figure 5-22: Rear Compression Belt Position).



**Figure 5-22: Rear Compression Belt Position**

6. There are four (4) holding screws (H) that hold each of the take-up blocks to the channels. They pass through slots and are on the underside of the channels just above the take-up rollers (see Figure 5-22: Rear Compression Belt Position and Figure 5-21: Front Compression Roller). Loosen the screws (H) just enough to allow the block to move. Loosening these screws too much will permit the shaft to tilt (skew) too much, making it difficult to align the new belt.
7. Inside each channel the take-up roller blocks are positioned using a hex-head bolt (T) (see Figure 5-22: Rear Compression Belt Position and Figure 5-21: Front Compression Roller). Turn this take-up bolt (T) so that it rotates into the block, allowing the block to move towards the drive sprocket and compression roller. Keep doing this until the old compression belt can be removed.
8. Place the new compression belts (part no. 17423) around the assemblies. Be sure to use genuine Fischbein parts.
9. Turn the take-up bolt (T) so that it rotates out of the block. This should begin to tighten the compression belt. The holding screws (H) should be loose enough to allow the block to move without permitting the shaft to tilt too much.
10. Tighten the holding screws (H). Push in on the side of the belt between the drive sprocket and the take-up roller. The belt should deflect about  $\frac{3}{4}$  inches (19mm) (see Figure 5-22: Rear Compression Belt Position).
11. Make sure that the holding screws (H) are tight before engaging the compression roller.
12. To adjust the compression rollers refer to "COMPRESSION BELTS" on page 5-4.



## 5.2.2. COMPRESSIONROLLERS

The compression rollers are designed with two bearings that fit around the bushing of the assembly (see Figure 5-23: Compression Roller Components).

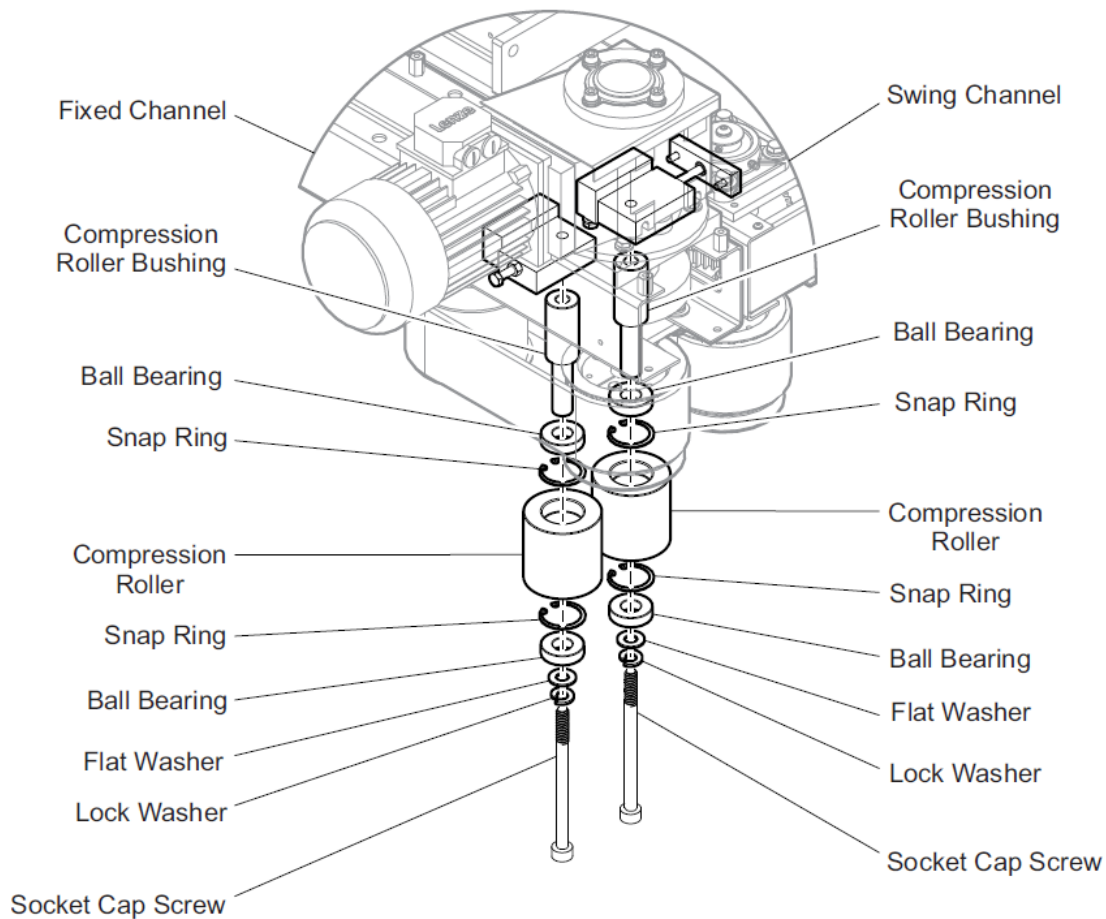

**Figure 5-23: Compression Roller Components**

After extended use of the PBC, the rollers and bearing will need to be replaced. Fischbein offers the rollers with the bearings mounted in the roller. To replace the rollers, follow these steps:

1. Turn **OFF** and lock out the electrical and pneumatic supplies to the PBC machine.
2. Remove the rear and front channel shrouds. Also remove the top channel cover, which is near the drive motor.
3. Loosen each of the two, ½ inch socket cap screws, which act as the shafts for the compression roller assemblies (see Figure 5-6: Fixed Channel Compression Roller Components and see Figure 5-9: Swing Channel Compression Roller Components).
4. **FIXED CHANNEL:**

To move the rear compression roller away from the compression belt, loosen the jam nut then turn the compression tension adjustment screw (C) into the block (see Figure 5-7: Compression Tension Adjustment Screw & Jam Nut). This will allow the block to be moved away from the belt.



## 5. SWING CHANNEL:

5. To move the front compression roller away from the belt, the adjustment screw (A) must be turned clockwise into the block. This will pull the block from the center of the machine so the roller mechanism can be replaced (see Figure 5-10: Front Compression Roller Adjustment).
6. Remove the two ½ inch socket cap screws from their respective blocks. The screw and rollers should come loose from the bottom of the channels (see Figure 5-6: Fixed Channel Compression Roller Components and Figure 5-9: Swing Channel Compression Roller Components).
7. If the bushing is still on the ½ inch screw, pull it off as well as the roller. Take careful note to the orientation of the bearings in the rollers and how they are placed on the shafts.
8. Place the new rollers (with bearings) onto the shafts as shown in Figure 5-23: Compression Roller Components. Place the bushings back in place.
9. Carefully thread the shafts back into the blocks in the channels. The socket cap screws should be turned enough to keep it fairly vertical and yet permit the block to be moved.
10. To properly set the rollers in position with the belts, follow the instructions in the "COMPRESSION BELTS" on page 5-4.

### 5.2.3. TAKE-UP ROLLERS

The take-up rollers provide the tension in the compression belts. They also act as guides for the bag tops as they begin to enter the compression process. After normal wear, the rollers and bearings will need to be replaced. The replacement rollers come with the bearings installed (see Figure 5-24: Take-up Roller Components). When replacing the rollers, always replace the front and rear rollers at the same time. To replace the rollers, follow these steps:

1. Turn "OFF" and lock out the electrical and pneumatic supplies to the PBC machine.
2. Remove the fixed and swing channel shrouds. Also remove the top cover closest to the drive motor.
3. To remove the take-up rollers, the tension in the compression belt must first be removed. This is done by turning the take-up adjustment bolt (T) into the block (see Figure 5-24: Take-up Roller Components). Do not turn the screw too far into the block to the point where it begins to tighten again.
4. Loosen the ½ inch socket cap screws (take-up block only) (see Figure 5-24: Take-up Roller Components). This is done from the bottom of the rollers. Do not remove the screws.
5. Each take-up block is held in position by the four holding screws (H) on the bottom of the channels. These screws pass through slots to allow for adjustments. Loosen the holding screws (H), but do not remove them.
6. Remove the ½ inch socket cap screws from their respective blocks.
7. If the bushings are still on the screws, then remove them as well (see Figure 5-24: Take-up Roller Components).
8. Remove and replace the take-up rollers. Take careful note as to the orientation of the rollers to the shafts. Place the bushings back on the screws.

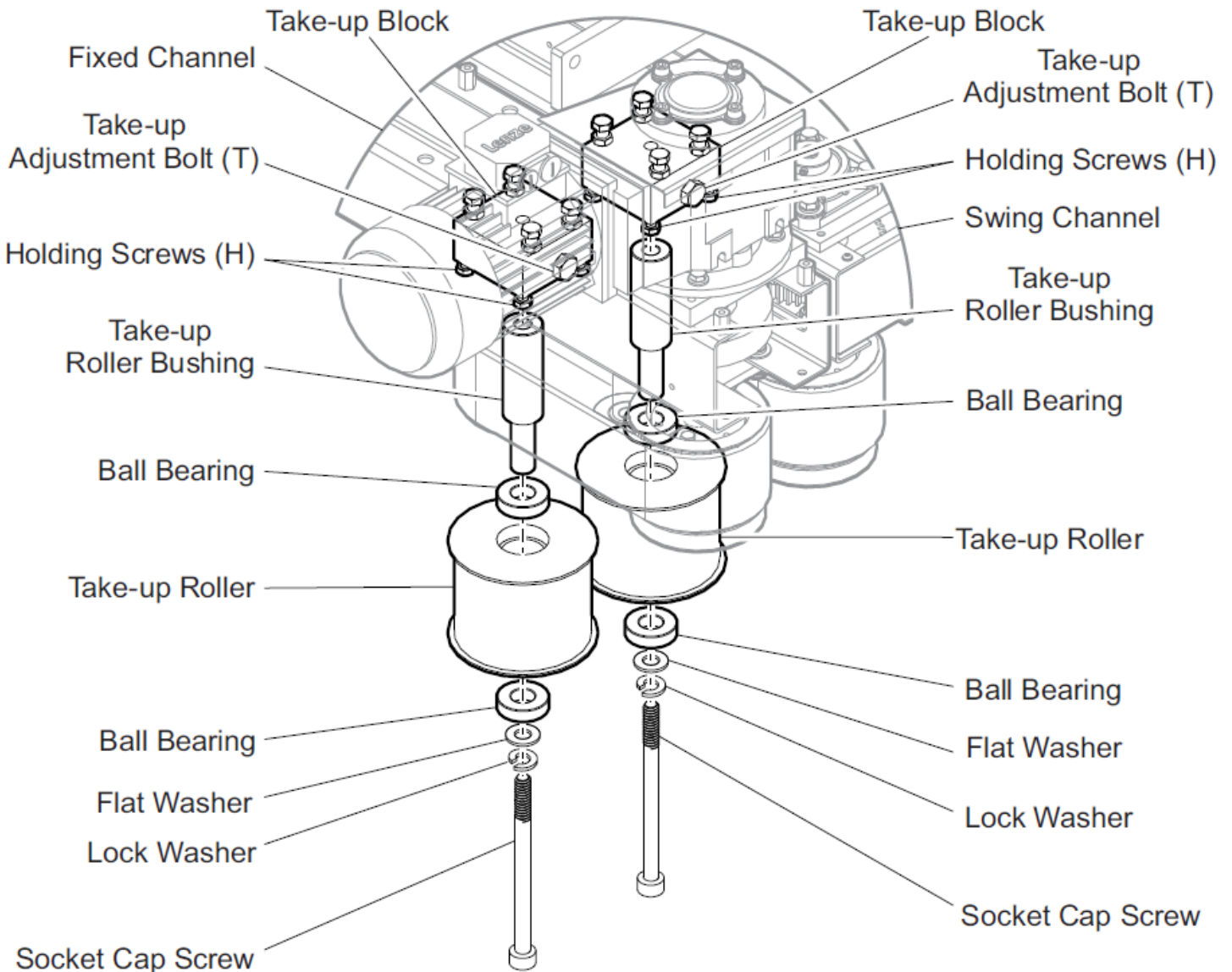

**Figure 5-24: Take-up Roller Components**

9. Screw the screws back into the blocks enough to keep them vertical and yet allowing the blocks to be moved.
10. Begin turning the block adjustment screw (T) out of the block. This should start tensioning the compression belt. Do not over tighten the belt at this point.
11. Tighten the holding screws (H) and the ½ inch screw into the block.
12. Check the tension in the belt by pushing in on the belt between the take-up roller and the drive sprocket. The belt should deflect in by ½ to ¾ inch (13 to 19mm) with a reasonable amount of force (see Figure 5-8: Correct Compression Roller Position). If the belt needs to be adjusted further, the ½ inch screws and screws (H) will have to be loosened (slightly) and the adjustment screw (T) turned.
13. Before mounting the shrouds and cover, make sure all the screws and bolts are tight. Also check the positioning of the compression rollers. Install the shrouds and top cover back into position.
14. Turn **ON** the electrical and pneumatic supplies to the machine.
15. Run some test bags through the machine with the heaters off and then on to check the performance of the rollers.



## 5.2.4. DRIVE SPROCKETS AND TENSION PULLEYS

### 5.2.4.1. Infeed Idler Pulleys

The infeed assembly is designed to control the tension in the carry through belts. The belt passes through the infeed and around an idler pulley. After normal usage, the pulley will need to be replaced. The replacement pulley comes with a bearing set in it and a thrust washer. The top plate of the infeed has the pulley shaft welded to it.

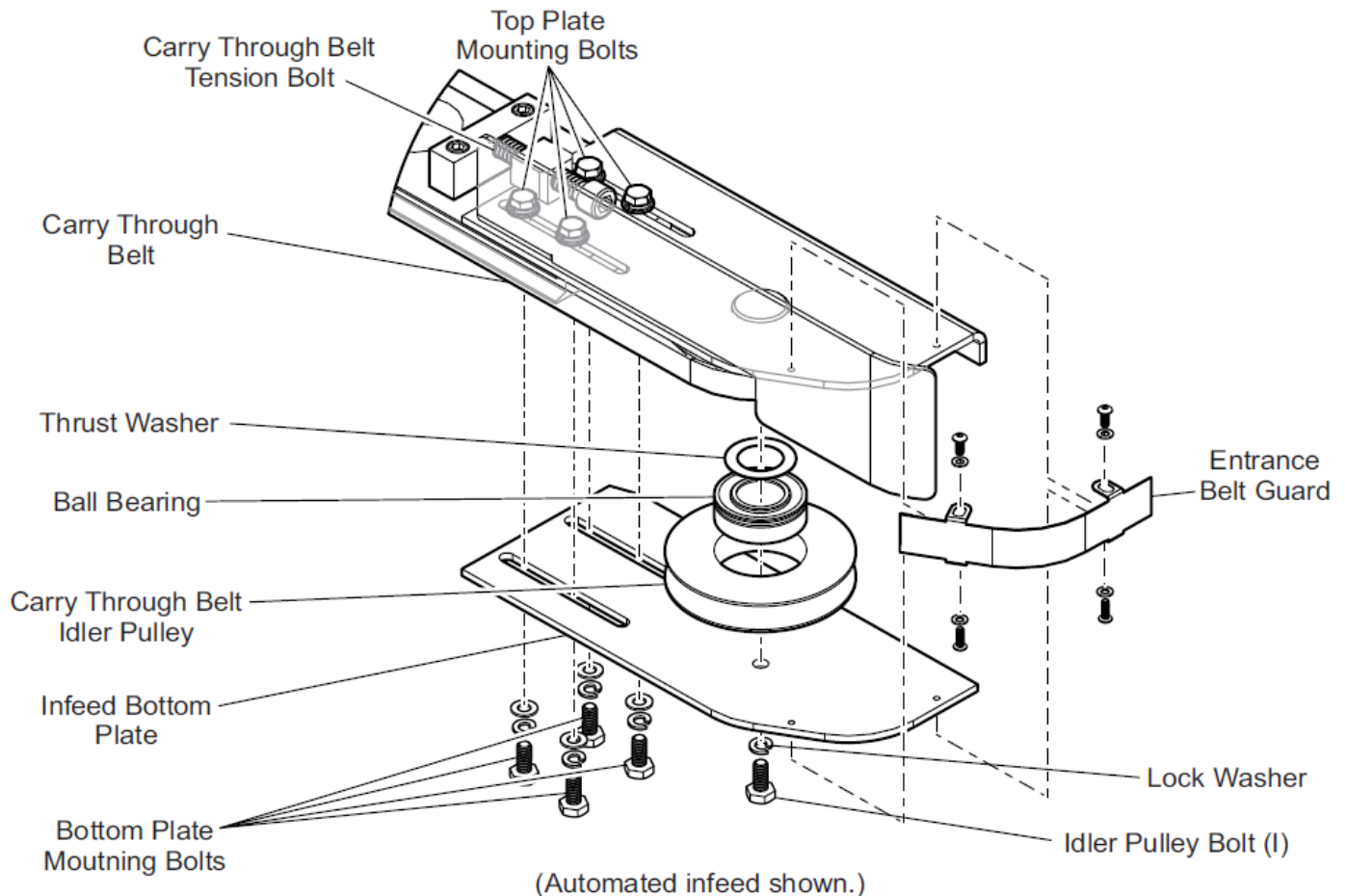

Figure 5-25: Infeed Idler Pulley Components



**CAUTION: WHEN AN IDLER INFEEED PULLEY NEEDS TO BE REPLACED, ALWAYS REPLACE BOTH PULLEYS.**

To replace the pulley, follow these steps:

1. Turn **OFF** and lock out the electrical and pneumatic supplies to the PBC6000.
2. Remove the front and rear shrouds.
3. Remove the entrance belt guards from the leading edge of the infeed (see Figure 5-25: Infeed Idler Pulley Components).
4. Loosen, but do not remove, the four top mounting bolts and four bottom mounting bolts for the fixed and swing channel infeeds.



5. Turn the tension bolt counter-clockwise to reduce the tension in the carry through belts.
6. Remove the four bottom mounting bolts from the fixed and swing channel infeeds.
7. Remove the idler pulley bolt (I) from the bottom of the infeeds. The infeed bottom plate can now be removed from the assembly.
8. Turn the tension bolt enough to remove the carry through belt.
9. Carefully remove the pulley from its shaft. Be sure to remove the old thrust washer from between the pulley and the top plate of the infeed.
10. The new pulley comes with the bearing pressed in place and a thrust washer. Install the thrust washer on the shaft first.
11. Install the pulley on the shaft with the flat (flush) side against the thrust washer (up). The bearing is pressed into the pulley so that it is flush with the pulley surface on one side and extending beyond the face of the pulley (slightly) on the other side. If the pulley is not installed correctly, the pulley will rub against the infeed plates.
12. Put the carry through belt on the pulley and turn the tension bolt enough to hold the belt on the pulley.
13. Install the infeed bottom plate using the four bottom mounting bolts and the idler pulley bolt (I). The mounting bolts should hold the plate in position and allow the infeed assembly to move. The idler pulley bolt (I) can be tightened, but not so much to prevent the pulley from freely rotating.
14. Turn the tension bolt until the desired tension is in the carry through belts. A belt with the proper tension will deflect between  $\frac{1}{2}$  to  $\frac{3}{4}$  inch (13 to 19 mm), when pulled from the middle of the belt with a reasonable force (see Figure 5-26: Proper Carry Through Belt Tension).

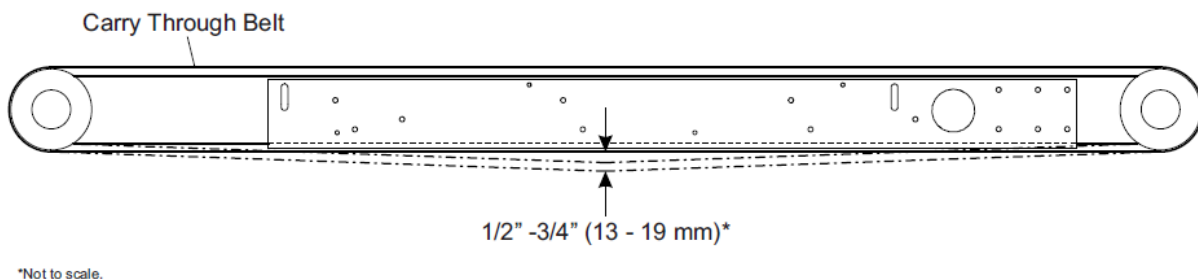

**Figure 5-26: Proper Carry Through Belt Tension**

15. Once the tension is set, tighten the four top and bottom mounting bolts on both infeed plates (See “Infeed Idler Pulley Components” on page 25.).
16. Install the entrance belt guards on the infeed of the machine.
17. Install the fixed and swing channel shrouds.
18. Turn **ON** the electrical and pneumatic supplies and proceed to test the machine. Use test bags with the heater turn off to determine if the pulley is performing smoothly.

#### 5.2.4.2. Carry Through Belt Drive Pulleys

The drive shafts drive two belts, the compression belts and the carry through belts. The drive pulley for the carry through belt is attached to the bottom of the shaft. Occasionally check the screws, which hold the pulley to the



compression drive sprocket. Since the pulleys attach directly to the compression sprockets, they do not contain bearings. Unless a pulley becomes damaged, it will not need to be replaced. If the pulley does need to be replaced, follow these steps:



**CAUTION: WHEN A CARRY THROUGH DRIVE BELT PULLEY NEEDS TO BE REPLACED, ALWAYS REPLACE BOTH PULLEYS.**

1. Turn **OFF** and lock out the electrical and pneumatic supplies.
2. Remove the fixed and swing channel shrouds.
3. Loosen, but do not remove, the four top and bottom mounting screws on the infeed (see Figure 5- 25: Infeed Idler Pulley Components).
4. Turn the tension bolt until the tension in the carry through belt has been removed and the belt can be removed (see Figure 5-25: Infeed Idler Pulley Components).
5. Remove the three screws, (D) that hold the pulley to the compression sprocket bottom (see Figure 5-27: Carry Through Belt Drive Pulley Components).

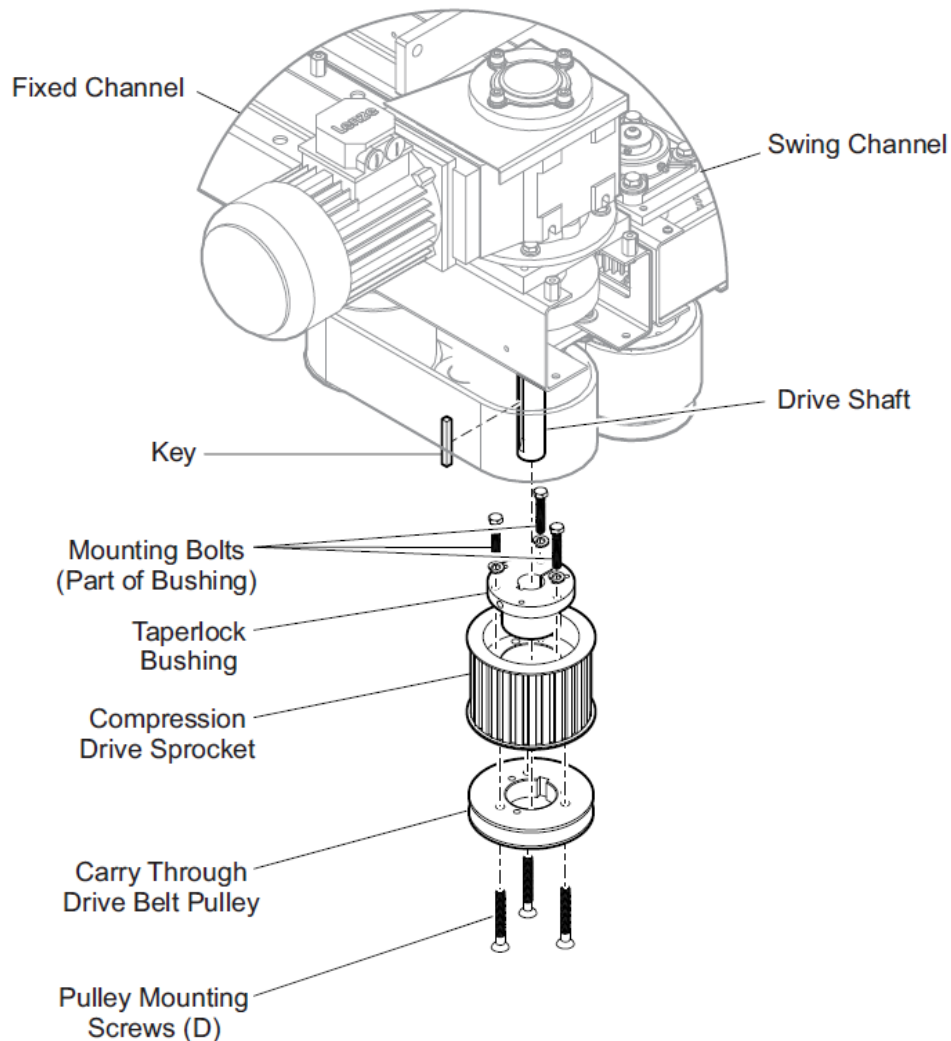

**Figure 5-27: Carry Through Belt Drive Pulley Components**



6. Mount the new pulley on the bottom of the compression sprocket using the mounting screws (D).
7. Place the carry through belt back on the pulley and turn the tension bolt, until the desired tension is achieved. A belt with the proper tension will deflect between  $\frac{1}{2}$  to  $\frac{3}{4}$  inch (13 to 19 mm), when pulled from the middle of the belt with a reasonable force (see Figure 5-26: Proper Carry Through Belt Tension).
8. Tighten the top and bottom mounting bolts for the infeed to keep the carry through belt at the desired tension.
9. Install the fixed and swing channel shrouds.
10. Turn **ON** the electrical and pneumatic supplies to the PBC6000. Check the pulleys for proper functioning.

### 5.2.4.3. Compression Belt Drive Sprockets

The compression belt of the PBC6000 is driven by a toothed sprocket (see Figure 5-27: Carry Through Belt Drive Pulley Components) for accurate timing. The sprocket should not need to be replaced unless it becomes damaged. Replacing the sprocket should only be done by a trained technician. If the sprocket needs to be replaced, please contact your Fischbein representative.

### 5.2.5. HOT AIR (HEATER) MANIFOLD

After normal usage, the heater element within the manifold will have to be replaced. Whenever the machine is being turned **OFF**, be sure to always let the pneumatics continue to run until the element has reached room temperature. Turning the pneumatic supply to the machine **OFF** while the element is still hot will damage the heater and the pneumatic lines. There are a couple of signs that the element has burned out. If you suspect that the element has burned out, the best way to verify is by checking for current through the element lead wires. This can easily be checked with a current clamp meter when the system and heaters are turned on.

#### 5.2.5.1. Removing the Heater Elements



**CAUTION: ONLY TRAINED AND LICENSED ELECTRICIANS SHOULD REPLACE THE HEATING ELEMENT OF THE MANIFOLD ASSEMBLY.**



**WARNING: TURN OFF AND LOCK OUT THE MAIN ELECTRICAL AND PNEUMATIC SUPPLIES BEFORE REPLACING THE HEATER ELEMENT IN THE MANIFOLD ASSEMBLY. FAILURE TO DO SO COULD RESULT IN SERIOUS INJURY!**

1. Turn **OFF** and lock out the electrical and pneumatic supplies to the machine.
2. Remove the swing channel (front) shrouding to access the hot air manifold assembly.
3. In order to place the manifold back into its original place after being removed, you may wish to take some measurements or make some marks on the carry through plate before removing the manifold.
4. Open the rear main electrical control panel and locate the lead wires from the heating element. Follow the electrical prints (in the pocket of the electrical enclosure door) to disconnect the heater element wires.



5. Disconnect the 1/2" pneumatic supply line from the pneumatic connection on the manifold (see Figure 5-28: Sealed Heater Cartridge Manifold).
6. Remove the socket cap screws that secure the manifold to the carry through plate and remove the manifold.

**Note:** There is a 1/4" flat washer underneath each heater manifold tab (see Figure 5-18:  Heater Manifold Guide Positioning).

7. Remove the screws (M) and spring washers which hold the manifold end plate to the rest of the manifold body. Remove the entire inner assembly from the manifold body. Pay special attention to the orientation of the heater cartridges. Mark the outside of the heater cartridge.
8. Inspect and thoroughly clean the empty manifold body. Examine the topside where all of the holes are. Make sure none of the holes are obstructed by glue or debris. The holes can be cleaned using a 1/16" or smaller drill bit.
9. Make sure that the manifold is dry and that whatever cleaning solution you used is completely removed from the manifold before assembling and putting it back into service.
10. Remove the jam nuts securing the heater cartridge to the end plate. Discard the old cartridge and the insulation.

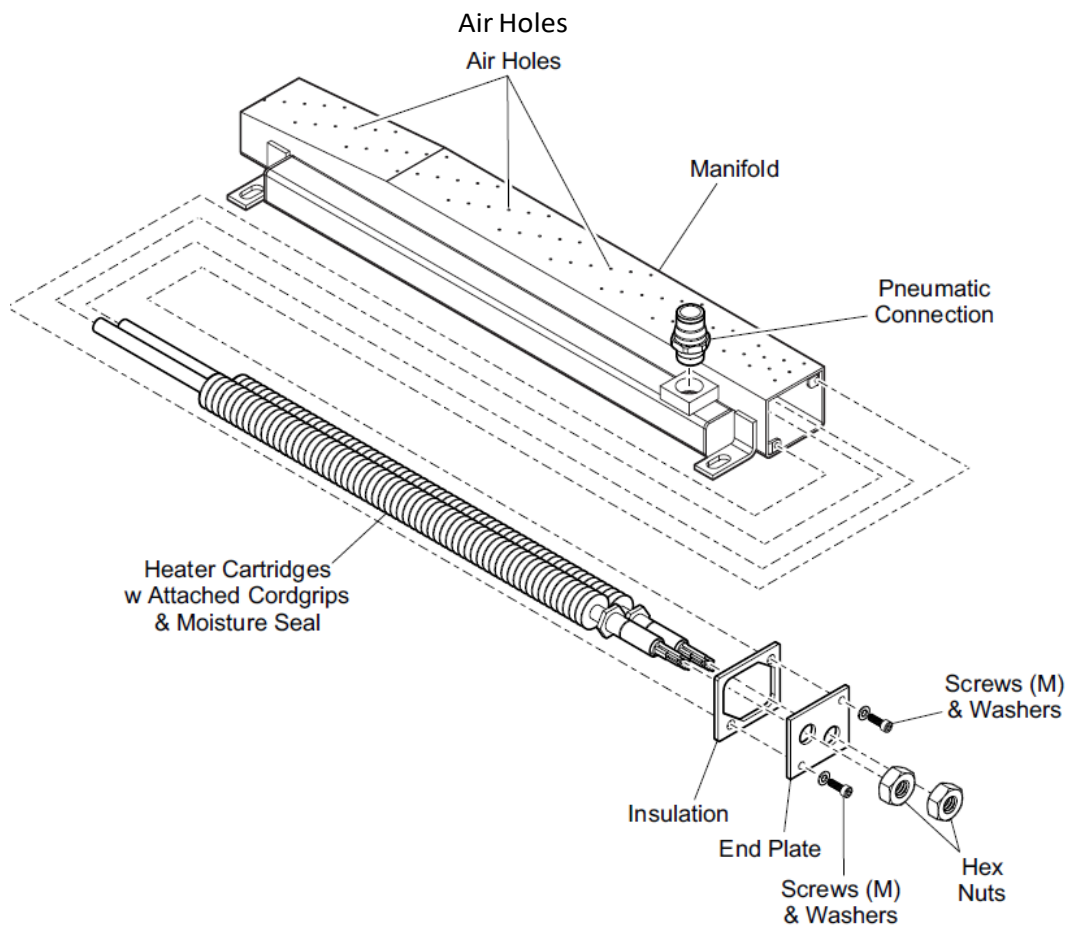



Figure 5-28: Sealed Heater Cartridge Manifold



## 5.2.5.2. Replacing the Heater Elements

1. Slide the threaded ends of the heater cartridges through the holes in the end plate.
2. Secure the cartridges to the end plate using the jam nuts.
3. Position a new piece of insulation on the end plate.
4. Slide the entire assembly into the manifold and install a new set of (M) screws and spring washers. Tighten.
5. Position the manifold in place based on the prior measurements or markings you made in step 3. Secure the manifold assembly into position using the fasteners. Remember to put one flat washer under each tab. There should be a 1/8" air gap between the manifold body and its guide. The guide should rise about 1/4 inch (6,4mm) above the top surface of the manifold body (see Figure 5-18: Heater Manifold Guide Positioning).
6. Check the lead wires as they pass through the channel systems to ensure that they are not interfering with the closing of the swing arm or tangling on any other components.
7. Connect the pneumatic supply to the manifold's connector. Secure the electrical cables from the manifold to the carry through plate mounting shaft with cable ties. Make sure that the cables do not interfere with the creaser assembly.
8. With the power still be off, open the rear electrical enclosure. Using the electrical drawings located inside you need to test for a short circuit in the heater. An Ohm meter or a continuity tester can be used to check that there is no continuity (an open circuit) between each black wire heater wire and ground. Also, test each thermocouple wire; measure between the white to ground and the red to ground. If there is no continuity between all four wires and ground the heater is ready for service, then you will have to trace back and find the short.
9. Install the swing channel shrouding.

## 5.2.5.3. Testing and the AUTOTUNE Function

**Note: The AUTOTUNE function on the heat controller should be turned ON and allowed  to run after the heater cartridges have been replaced or the heat controller PID has been replaced.**

10. Turn the pneumatic and electrical systems **ON**. Close the swing arm and check the cartridge lead wires to make sure they are not interfering with any components.
11. Turn the heaters **ON**.
12. AUTOTUNE: To run the Autotune feature, press down and hold the ▲ and ▼ keys for three (3) seconds. The display will alternate showing **tunE** and **oFF**.
13. Press and hold down the \* key and the press the ▲ or ▼ key until the display shows **on**. Release the keys and the display will alternate between **on** and **tunE**. This indicates that the controller is going through the autotune process, which can take about 10 minutes. After a couple of minutes the display will alternate between the current temperature and **tunE**. Once the cycle has completed the controller will either display the current temperature at or near the set point or will display the current temperature with **-AL-** to show that it is finishing the warm up cycle.
14. Adjust the set temperature for the type of bags being tested.



15. After the machine has completely heated and the "READY" light has illuminated, feed some test bags into the machine and inspect them for quality closures. Refer to the QUALITY CONTROL GUIDE section of this manual to determine proper closures.

## 5.2.6. READY LIGHT



**CAUTION: ONLY TRAINED AND LICENSED ELECTRICIANS SHOULD REPLACE THE READY LIGHT.**



**WARNING: TURN OFF AND LOCK OUT THE MAIN ELECTRICAL AND PNEUMATIC SUPPLIES BEFORE OPENING THE CONTROL PANEL. FAILURE TO DO SO COULD RESULT IN SERIOUS INJURY!**

1. Open the control panel, and locate the READY light.
2. Flip open the lever securing the light housing to the lens and bezel.
3. Lift the light housing out of the bezel.
4. Remove and replace the LED.
5. Replace the light housing back onto the bezel.
6. Close the lever to secure the light housing to the bezel.
7. Close the control panel and restart the machine.

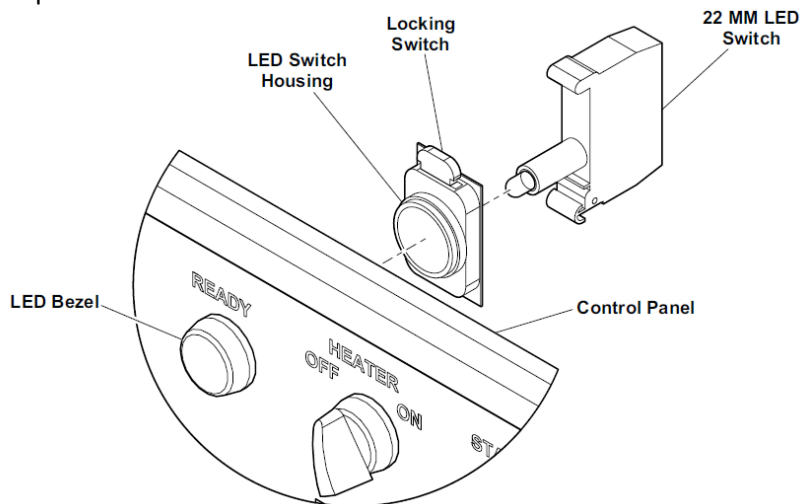

**Figure 5-29: READY Light Replacement**



## 5.2.7. TEMPERATURECONTROLLER



**CAUTION: ONLY TRAINED AND LICENSED ELECTRICIANS SHOULD REPLACE THE TEMPERATURE CONTROLLER.**



**WARNING: TURN OFF AND LOCK OUT THE MAIN ELECTRICAL AND PNEUMATIC SUPPLIES BEFORE OPENING THE CONTROL PANEL. FAILURE TO DO SO COULD RESULT IN SERIOUS INJURY!**

1. Open the control panel and locate the temperature controller.
2. Disconnect the three wires leading to the electrical controller.
3. Remove the screws and washers securing the electrical controller to the control panel, and discard the controller.
4. Position a new temperature controller on the control panel, and secure it using the screws and washers supplied.
5. Reattach the three wires to the temperature controller.
6. Close the control panel and restart the machine.

## 5.2.8. FLOW SWITCH



**WARNING: TURN OFF AND LOCK OUT THE MAIN ELECTRICAL AND PNEUMATIC SUPPLIES BEFORE REPLACING THE FLOW SWITCH!**

1. Disconnect the air line from the flow switch.
2. Follow the wire from the flow switch to the cordgrip on the main electrical enclosure, then loosen the cordgrip so that the wire can be pulled through it.
3. Open the main electrical enclosure.
4. Disconnect the flow switch wires from the terminal block (refer to the Electrical Schematic included with the machine).
5. Unscrew the flow switch from the regulator, and discard the flow switch.
6. Secure a new flow switch onto the regulator.
7. Feed the flow switch wire through the cordgrip and attach it to the terminal block.
8. Tighten the cordgrip.
9. Reattach the air line to the flow switch.
10. Shut the main electrical enclosure and restart the machine.

## 5.2.9. DRIVE MOTOR & BEARINGS

After normal usage the drive motor and bearings for the drive shafts may need to be replaced. If the drive assembly needs replacement, please contact your Fischbein representative.



## 6. MAINTENANCE



**CAUTION: A CERTAIN AMOUNT OF TECHNICAL KNOWLEDGE IS REQUIRED TO PERFORM PROPER MAINTENANCE ON THIS MACHINE. NEVER ALLOW UNTRAINED PERSONNEL TO PERFORM MAINTENANCE ON THIS MACHINE. DOING SO COULD RESULT IN DAMAGE TO THE MACHINE OR INJURY TO PERSONNEL.**



**WARNING: TURN OFF AND LOCK OUT THE POWER DISCONNECT SWITCH ON THE BACK OF THE ELECTRICAL ENCLOSURE BEFORE PERFORMING ANY MAINTENANCE FUNCTIONS! FAILURE TO DO SO COULD RESULT IN SERIOUS INJURY OR DEATH!**



**WARNING: THE HEATER IS EXTREMELY HOT! THIS WILL CAUSE SEVERE BURNS AND INJURIES TO MAINTENANCE PERSONNEL. ALWAYS ALLOW THE HEATER TO COOL DOWN BEFORE PERFORMING ANY MAINTENANCE.**

### 6.1. Daily Maintenance

1. While the front swing channel is in the open position:
  - A. Inspect the belts after opening the breakaway assembly. Remove any glue on the belts with a dull flat edged tool. Be careful not to gouge the surface of the belts
  - B. Remove all paper scraps and debris from the machine.
  - C. Remove any glue build-up on the folder, hot air manifold, guides and belts.
2. Open the bleed valve on the pre-filter and filter to remove oil and moisture from the pneumatic system. If oil is found in the air supply, this problem must be corrected immediately. Change filters as needed and regularly. The machine is designed to use clean, dry, non-lubricated compressed air.



**WARNING: OIL IN THE COMPRESSED AIR CAN CAUSE A FIRE!**

3. Check the compression belt's tension and adjust if needed.
4. Check the hot air manifold, ensuring the air holes are free of debris.
5. Center the machine with the conveyor.
6. Replace any burned out lamps



## 6.2. Monthly Maintenance

1. Check the air pressure to the machine. Minimum pressure should be 90 PSI (6,2 bar) with the capacity to provide 400 SCFH (11,3 SCMH) and the airflow gage should be set to at least 400 SCFH (11,3 SCMH).
2. Examine all belts for wear and determine if they need to be tightened or adjusted.
3. Check creaser wheel groove and blade for cleanliness, wear and proper alignment. Make sure the set screws are tight.
4. Lubricate the spur drive gears to the channel assemblies. Use high-temperature grease only, to prevent grease contamination to other parts of the machine. Use sparingly!
5. Check the drive chain tension for the lift mechanism of the frame. Make sure that the tension completely holds the chain on the teeth of the sprocket gears. Lubricate the drive chain and gears at least twice a year.
6. Replace air pre-filter and filter if dirt or oil is in the air system. Check the pneumatic lines for wear and replace them as needed.
7. Check the shoulder bolts for the swing channel pivot points (see Figure 6-1: Swing Channel Pivot Point Shoulder Bolts) for excessive wear that will warrant replacement.

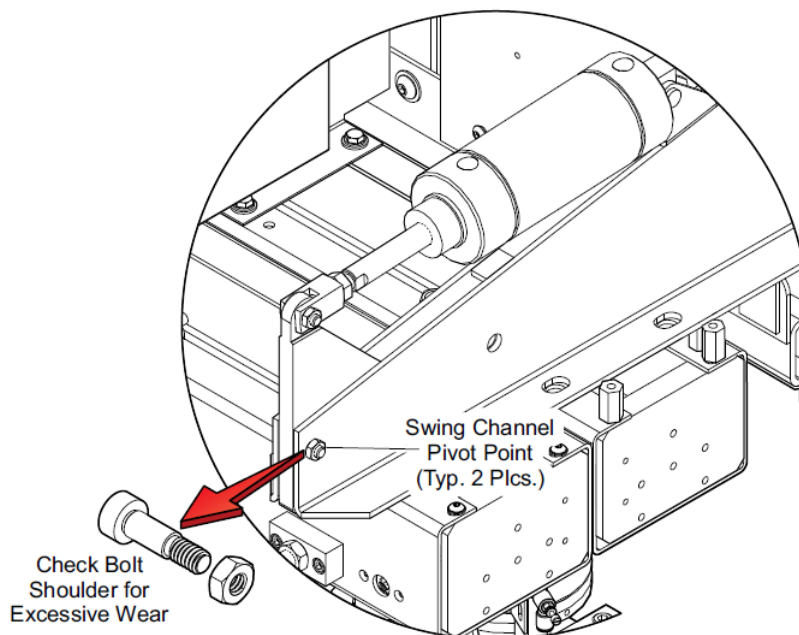

**Figure 6-1: Swing Channel Pivot Point Shoulder Bolts**

8. Test the bag jam detection to make sure that the swing channel will open if a bag jams in the system. Fold over a sample bag twice to make the bag thick and insert it into the infeed so that the bag is only going to contact the carry through belts. The swing channel should open due to the proximity switch within the fixed channel.
9. Check the airflow sensor, by reducing the flow using the main regulator. Perform this test while the system is **ON**, without any bags going through the system. The machine should turn off when the flow has gone below the safe margin.



## 6.2.1. SYSTEM FRAME

### 6.2.1.1. Casters

Check and lubricate the casters. Ensure that they are firmly attached to the frame. Two of the casters are capable of being locked for stabilizing the machine while in operation. Check the locks to ensure that they are functioning properly. If the locks fail to work, replace as soon as possible.

### 6.2.1.2. Height Adjustment System

The frame is designed to allow the operator to adjust the vertical height of the machine. The vertical adjustment is controlled by two threaded rods, located within the two main vertical tubes of the frame (see Figure 6-2: Height Adjustment System). The machine utilizes a crank handle, with sprocket gears and a chain to turn the threaded rods. A locking lever is located near the handle to keep the machine at the specific height. Weld beads on the threaded rods help prevent the manual systems from turning too far.

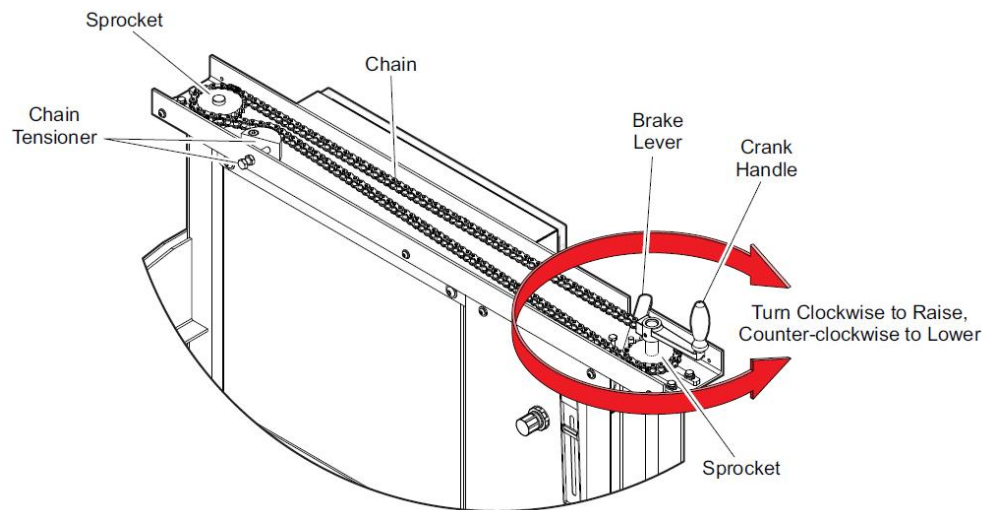

Figure 6-2: Height Adjustment System

## 6.2.2. PNEUMATICS

The air source connection has a female quick release air coupling (Foster Series 3, #3003 or equivalent) which connects to the safety shut-off valve located on the pneumatic control panel (see Figure 6-3: Pneumatics Control System). Air hose connections should have a minimum 1/2 in. (13 mm) ID. The machine requires compressed, clean, non-lubricated air. The supply should be capable of sustaining 90 PSI (6,2 bar) of pressure and a volume flow rate of at least 420 SCFH (11,9 SCMH).

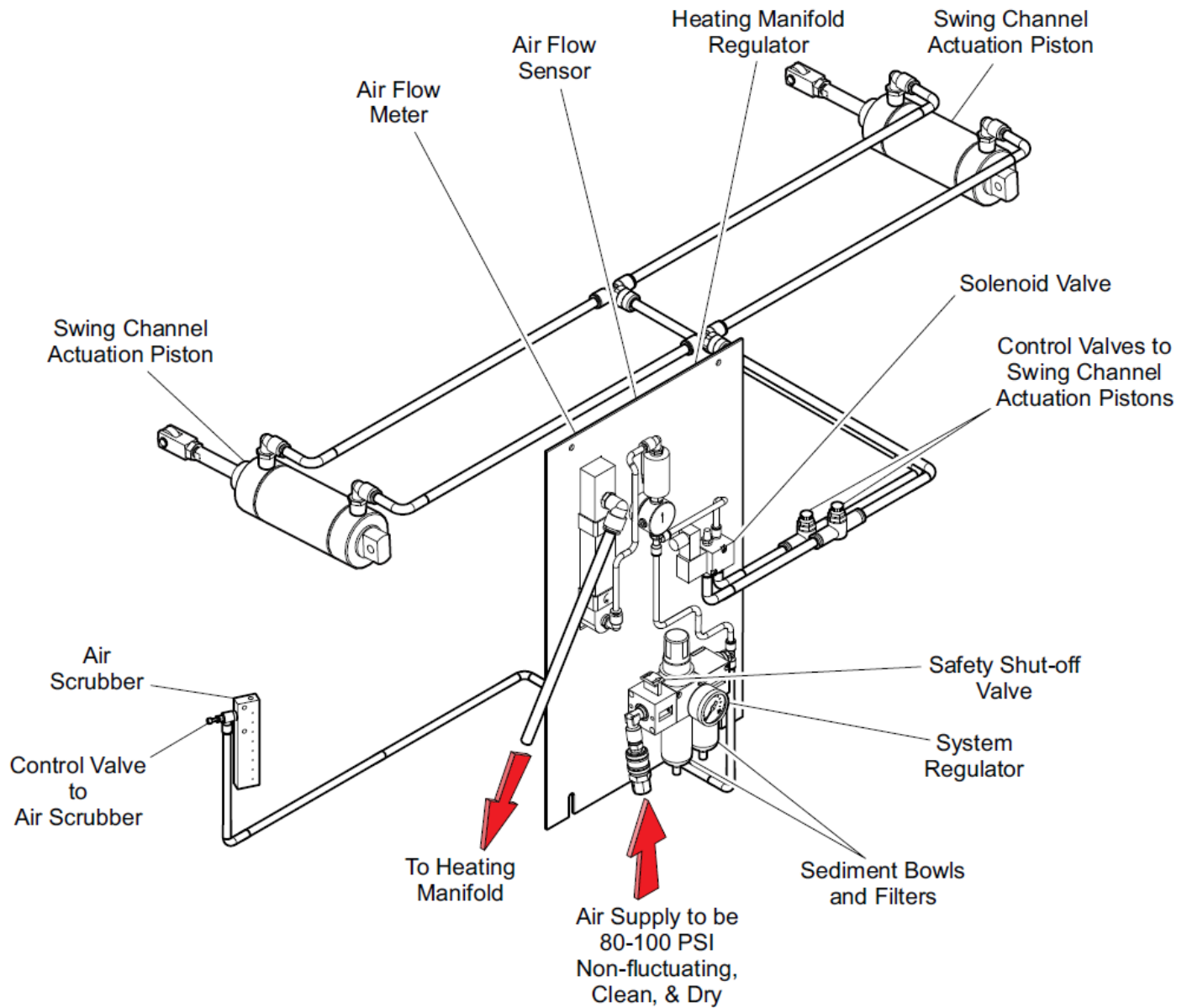

Figure 6-3: Pneumatics Control System

### 6.2.2.1. Sediment Bowls and Air Filters

Check the pneumatic system for air leaks at the connections and control panel. Inspect the sediment bowls and air filters for debris and oil. If oil is found in the filters, replace the filters and correct the air supply problem immediately.

### 6.2.2.2. Airflow Valves and Gauge

The flow valves are shipped from the factory adjusted to allow the swing channel to open slowly and to maximize the cleaning effect of the air scrubber on the bag top. In most cases the swing channel valve can be left in this position. The air scrubber should be adjusted based on your application and need.



## 6.2.3. SENSORS

### 6.2.3.1. Thermocouples

The thermocouple is attached to the end plate of the heater manifold. If you suspect that a thermocouple has become defective, remove the defective thermocouple and replace it with a new one.

### 6.2.3.2. Proximity Sensors

The machine uses a proximity switch inside the swing channel to determine when the swing channel has completely engaged. As the swing channel is **CLOSED** into position to run, the proximity switch rises up until it reaches the underside of the target sensor plate, near the electrical control enclosure. For this reason, the **CLOSE** buttons are simultaneously pushed and held until the swing channel has completely closed. If the buttons are released before the swing channel has completely rotated into position, the channel will disengage and rotate open. If the buttons are pushed and held, but the swing channel never stays in the closed position, the proximity switch may have come loose or needs to be replaced. Carefully follow the electrical prints in the electrical enclosure to replace the switch.

### 6.2.3.3. Airflow Sensor

An airflow sensor has been installed with the pneumatic system to protect the machine's heaters. (Figure 6-3: Pneumatics Control System) The heaters in the manifold can overheat and become defective if insufficient air flows through the manifold. The airflow sensor continuously monitors the pneumatic system for a minimum amount of airflow, necessary for safe operation. If the airflow drops below a safe level, the heaters will automatically be turned off and the machine deactivated. If there is sufficient air flow through the system, but the sensor will not allow the heaters to activate, then the sensor may need to be replaced.

Be sure to always use clean, dry, non-lubricated compressed air. Regularly check the air filters and sediment bowls for signs of contaminants.

## 6.2.4. COMPRESSION BELTS

The compression belts work with the compression rollers to create a secure bond in the fold. It is a specially coated timing belt that grasps the bag top after the carry through belts begin to release the bag and compresses the fold. After the folder, the carry through belts start to taper slightly away from the centerline of the machine and the compression belts finish transporting and compressing the bag. The coated belt is wide to accommodate a variety of fold widths.

### 6.2.4.1. Compression Belt Upkeep

The compression belts must provide even pressure across the fold as bags pass through the machine. Belts with deep gouges or glue buildup will not produce even pressure area across the fold. Glue left on the belts will likely deposit on the following bags, defacing the appearance of the bag. Keep the belts clean and free of glue buildup. Use a dull edged tool to gently remove the glue from the belts.

NEVER use a metal edge (such as a screw driver or putty knife) to remove the glue. A clean rag and some mild soap can be used to clean the dirt from the belts.



### 6.2.5. HOT AIR (HEATER) MANIFOLD

The hot air manifold has been designed as a self-contained assembly. The actual heater is contained within the manifold. This design provides fast heating of the air, which is then directly blown on the bag top and adhesive. The strategically placed holes in the manifold top provide the means for the hot air to blow on the bag top.

If the holes become clogged with glue build up or debris, the effectiveness of the system is reduced. The holes must be kept clean and free of debris. Use a dull edged tool when cleaning glue from the manifold. Occasionally check that the bolts that hold the manifold assembly to the carry through plate are tight.

### 6.2.6. DRIVE MOTOR AND GEARS

The machine is powered by a drive motor, located above the compression area of the machine. The motor is responsible for turning the drive shafts that power all of the belts. The shaft in the fixed channel is directly connected to the drive motor. When the swing channel is closed, a set of spur gears on the drive shafts mesh together, providing power to the swing channel system (see Figure 6-4: Compression Belt Position).

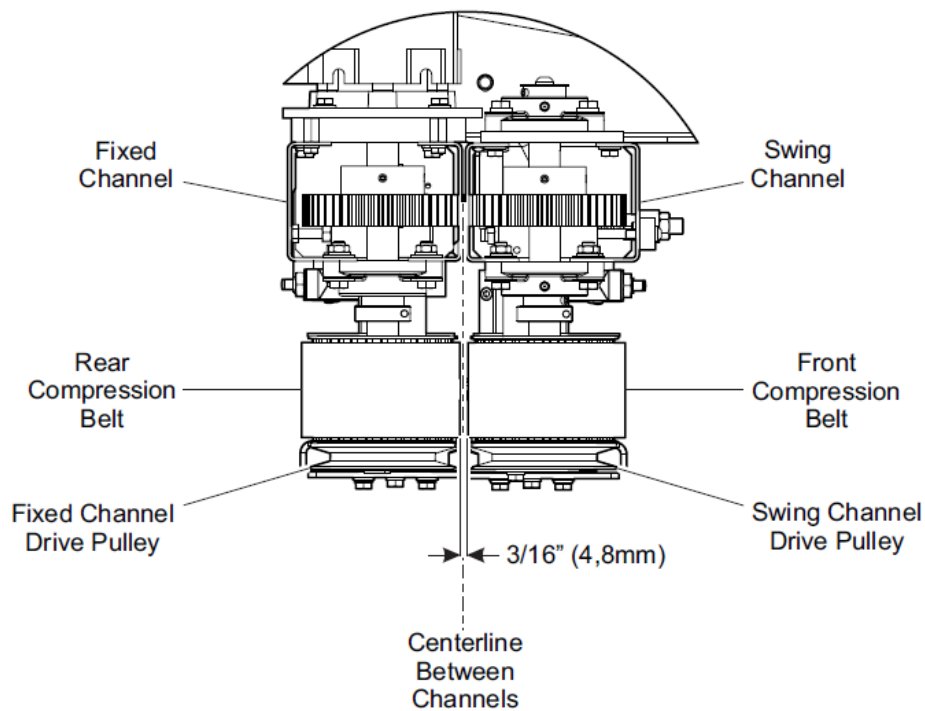

**Figure 6-4: Compression Belt Position**

The spur gears should be lubricated with grease at least once a month. The fasteners that connect the motor to the channel should be checked to ensure that they are secured to the frame. Once the fixed and swing channel shrouds are removed, the shafts, gears and blocks can be inspected for loose fasteners. It is imperative that the gears remain across from each other and that the shafts are parallel to each other, when the swing channel is closed.



## 7. QUALITY CONTROL GUIDE

The purpose of this section is to provide guidance for quality control departments in determining their own specifications for bag closures. It also outlines the conditions and adjustments needed to achieve the desired closure. The machine has been designed to heat an adhesive -coated flap and then fold the flap over 180° to seal the end of a bag top.

### 7.1. General Conditions for a Good Seal

#### 7.1.1. CORRECT ADHESIVE TEMPERATURE

The temperature of the heater element is determined and set based on the speed of the machine, the type of bag material and adhesive used, the ambient temperature of the bag, and the room temperature. Since any one of these factors may change through a working day, the seal should be inspected on a regular schedule to ensure a strong seal to the bag surface. Always start from a lower temperature and gradually increase as needed.

#### 7.1.2. BAG SURFACE PREPARATION

As with most adhesives, the bonding surface must be clean and free of debris. If a residue (powder, dust, moisture, oil) or product is left on the surface of the bag, near the bond area, the adhesive will not make a good bond to the bag material. Operators handling the bag tops should ensure that the bag is clean before it enters the machine. In dustier environments modifications may need to be made to keep contaminants off the bag surface. The machine is equipped with an air scrubber, which is positioned to blow clean, non-lubricated air across the seal area. If contaminants are still preventing a good seal, the air scrubber can be adjusted (by its control valve) to blow more air.

As the bag top enters the machine, its bonding surface should be flat and free of wrinkles. The machine will make a few small wrinkles within the creaser area, but operators need to ensure that the bags are not wrinkled before entering the machine.

Most bags are made so that their glue will adhere to the bag surface. If the bag has a high gloss surface, the bag manufacturer usually provides an area along the bag, which has been prepared for the hot glue. Test the bags to be sealed to ensure a compatible combination that will produce a strong seal.

#### 7.1.3. PROPER BAG PRESENTATION

Part of the success of sealing a bag top is presenting it to the machine at the correct height and parallel to the sealing line of the machine. The machine must be aligned with the conveyor in order to receive the bag top at the correct height and so that the crease line is parallel to the seal line. If the crease is located in the wrong area of the bag top, it may not completely seal. To seal the top of the bag, the seal, flap and creaser lines must be parallel to the conveyor.

Bags entering the system must not have large wrinkles. Large wrinkles in the bag top flap will not provide a complete seal.



## 7.2. Typical Bag Closures

### 7.2.1. PROPER CLOSURES

A properly closed bag prevents the sifting or leakage of products from its sealed ends. There are specific characteristics of properly closed bags. Properly closed bags have a strong complete seal along the entire length of the bag. After a bag has been sealed by the machine and allowed to cool, try pulling the seal apart from the outside of the bag. As the flap is torn away, the adhesive should contain fibers of the bag material from the opposite piece. Glue should be found on both sides of the seal.

Another way of testing the seal is to take a sealed bag that has cooled and cut the top 6 inches (153mm) bag top off. Begin pulling apart the seal from the inside of the bag. Check for unsealed areas within the gussets and along the entire length of the bag. Be certain to check for full contact between the two surfaces of the bag. A seal with many large wrinkles may provide an avenue for product to leak from the bag.

The appearance of the bag is important to the end consumer. The machine is fully capable of making a strong and attractive seal. The appearance of a seal becomes more important for bags that display art- work on the outside. The seal should be relatively straight and even. Some creasing can be expected at the gussets due to the changing thickness in the bag. If a flap has been sealed at an angle straight across the bag, adjustments should be made to correct the problem.

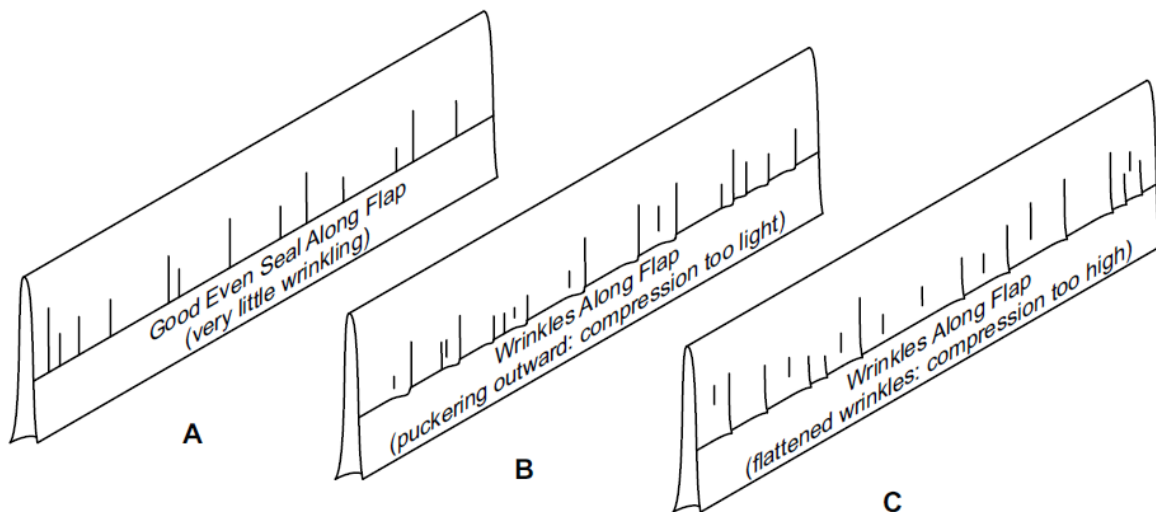

Figure 7-1 Bag Seal Comparison

### 7.2.2. PROBLEM CLOSURES

An incorrect closure compromises the integrity of the seal. If a closure is not complete due to a wrinkled or angled seal, the adhesive strip has not made full contact with the bag surface. Below is a description of the common types of problem closures that may occur and how to solve them.

1. The diagram in Figure 7-1 (A) represents a proper bag seal. Some creasing will occur near the gussets and small wrinkles will be present as a result of the creaser. The seal does make full contact along the bag when pulled apart and inspected.
2. The diagram Figure 7-1 (B) shows that the flap has not been completely compressed. The adhesive was likely heated to the correct temperature, but the compression rollers must force the melted glue into the fibers of the bag material on both sides of the seal. The wrinkles are present, but are not pressed flat to the bag surface (see "COMPRESSION BELTS" on page 5-4 and "COMPRESSION ROLLERS REPLACEMENT" on page 5-22).



3. The diagram Figure 7-1 (C) indicates that the bag has been sealed for the most part, but there are an excess amount of large wrinkles in the flap. They are compressed to the surface, but still may allow leakage of the product. Here are some of the possible causes:
  - A. Compression set too high. If the pressure between the two compression rollers is too great, the flap will move too easily with the hot glue being extruded from the flap bottom and trailing edge of the bag (see "COMPRESSION BELTS" on page 5-4 and "COMPRESSION ROLLERS REPLACEMENT" on page 5-22).
  - B. The pressure between the creaser blade and die is set too high. The creaser assembly must break the bag fibers to produce a line for the fold. The radial design of the creaser produces some wrinkles in the flap. If the pressure is set too high, the bag will have difficulties entering between the die and blade, causing large wrinkles (See "CREASER WHEEL" on page 5-9).
3. Figure 7-2: (D) shows the flap unevenly sealed. Uneven seals may leak product from one of the gussets and not provide sufficient strength along the entire seal. There are a couple of conditions that may cause this effect:

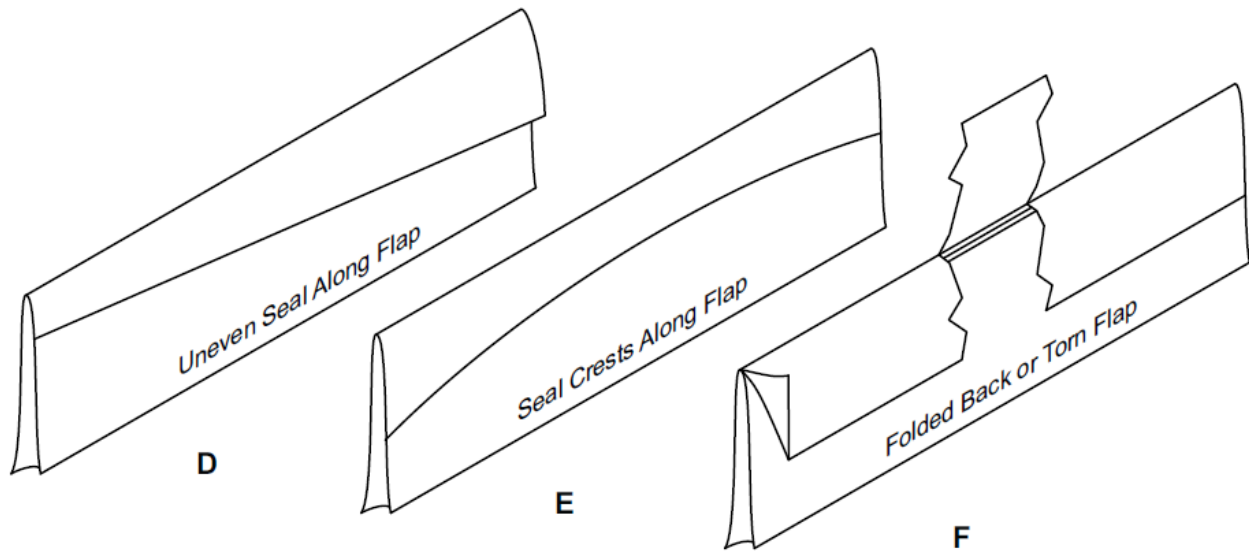

**Figure 7-2: Bag Seal Comparison**

- A. The most common cause is due to the angle that the bag top enters the machine infeed. Make sure your bag guides and operators are properly entering the bag tops into the infeed.
- B. The machine carry through belts are not synchronized with the conveyor system. Use a tachometer with a surface wheel tip to measure and adjust the speeds of the two systems. If the speeds conflict, then the bag will either lean forward or backward as it passes through the PBC.
- C. The bag top may be catching on an internal component as it passes through. Remove the front shrouding and inspect a bag as it passes through the machine. Check to see if any part of the bag is catching on machine components that would delay the top of the bag. Make adjustments to the component(s) as needed. Such as the pressure between the creaser wheels.

A common problem is caused by the glue build up on the inside of the folder. Clean the folder and manifold, using a dull edged tool to prevent scratching the surfaces. A gentle cleaning solution may be needed to remove the tacky film that remains. Check with your bag provider for a cleaning product recommendation.



4. Figure 7-2: (E) indicates excessive creasing at the leading and trailing edges of the bag flap. Although some creasing can be expected, too much will compromise the integrity of the seal. Here are some possible reasons for the excessive creasing:
- A. The pressure between the creaser blade and die is too great. As bags enter the creaser area, the creaser blade and die quickly compress a folding (crease) line below the glue region. The blade assembly is free to move towards and away from the die to compensate for varying thicknesses in bags, but still provides enough pressure to make an effective crease. If the pressure is too great, the bag will initially stall while entering the creaser area and cause the creasing effect at the leading and trailing edges. Adjust the pressure of the creaser blade (See “CREASER WHEEL” on page 5-9).
  - B. The creaser assembly is not properly aligned with the folder. The crease line should be entering just below the underside of the folder, near its leading end. Follow the instructions in “CREASER WHEEL” on page 5-9 to properly align the creaser assembly with the folder.
  - C. The bag top may be catching on an internal component as it passes through. Remove the front shrouding and inspect a bag as it passes through the machine. Check to see if any part of the bag is catching on machine components that would momentarily delay the top of the bag. Make adjustments to the component(s) as needed.
  - D. The gap setting between the bottom folder guide and the folder is too close. Once the flap has been folded about 90° and heated, the rest of the folder gradually folds the flap over onto the bag surface for bonding. If the gap between the upper and lower folders are too close (especially near the exiting portion of the assembly), the leading edge of the flap will attach to the bag too far back from the leading edge of the bag. The gradual folding effect near the end of the folders is designed to allow the flap to straighten out a little before making contact with the bag surface. Check the gap setting and adjust as needed. The standard setting for most bag types is about ¼ to 3/8 inch (6,4 to 9,5mm) (See “FOLDER AND GUIDES” on page 5-15). May also cause effect F.
  - E. The creaser blade and die must be directly across from each other. The path that the bag travels while passing between the blade and die must run parallel with the centerline between the carry through belts. If the die or blade is further to the right or left than the other, the bag will be directed towards the front or rear of the machine instead of straight into the folder assembly (See “CREASER WHEEL” on page 5-9).
  - F. The die is not properly aligned with the carry through belts. If the die is too far forward or backward from the carry through belts, then the bag top is deflected either towards or away from the folder assembly. Follow the instructions for setting the creaser die (See “CREASER WHEEL” on page 5-9).

In Figure 7-2: (F) the bag is being torn or is catching on components as it passes through the machine. Remove the swing channel shrouding and inspect a couple of bags passing through the system. Try to isolate the component where the bag is being stalled or jammed. Make adjustments to the component.



## 8. TROUBLESHOOTING



**CAUTION: A CERTAIN AMOUNT OF TECHNICAL KNOWLEDGE IS REQUIRED TO PERFORM PROPER MAINTENANCE ON THIS MACHINE. NEVER ALLOW UNTRAINED PERSONNEL TO PERFORM MAINTENANCE ON THIS MACHINE. DOING SO COULD RESULT IN DAMAGE TO THE MACHINE OR INJURY TO PERSONNEL.**



**WARNING: TURN OFF AND LOCK OUT THE POWER DISCONNECT SWITCH ON THE BACK OF THE ELECTRICAL ENCLOSURE BEFORE PERFORMING ANY MAINTENANCE FUNCTIONS! FAILURE TO DO SO COULD RESULT IN SERIOUS INJURY!**



**WARNING: SHOCK HAZARD! ALL ELECTRICAL TROUBLESHOOTING SHOULD BE PERFORMED BY A QUALIFIED ELECTRICIAN. FAILURE TO DO SO COULD RESULT IN SERIOUS INJURY OR DEATH!**



**WARNING: THE HEATER IS EXTREMELY HOT! THIS WILL CAUSE SEVERE BURNS AND INJURIES TO MAINTENANCE PERSONNEL. ALWAYS ALLOW THE HEATER TO COOL DOWN BEFORE PERFORMING ANY MAINTENANCE.**

This section of the manual has been provided to help address problems or situations that may possibly arise while operating the machine. For questions not answered in this manual please contact your local Fischbein representative or the “Customer Service Department” on page ii.

### 8.1. Questions Concerning Bag Seals

For troubleshooting the details surrounding the quality of a seal, please refer to the QUALITY CONTROL GUIDE.



## 8.2. General Closer Problems

Problem	Cause	Solution	Resource
Bag Jams Near Creaser	The gap between the edge of the blade and the die is too narrow.	Increase the gap to 3/16 inch (4,8mm).	See "CREASER WHEEL" on page 5-9.
	B) The pressure between the blade and die is too great.	Adjust the blade assembly pressure.	See "CREASER WHEEL" on page 5-9.
Green Ready Light Takes too Long to Illuminate	The heater element has become defective.	Replace the heater element.	See "HOT AIR (HEATER) MANIFOLD" on page 5- 28.
	The "READY" light has burned out.	Replace the READY light.	
	The temperature controller needs to be replaced	Replace the temperature controller.	
	The flow switch is faulting.	Replace the flow switch.	
Machine Keeps Turning Off after a Short Period of Time	Carry through belt tension is too high.	Check the tension in the carry through belt. To clear the error from the display, turn the machine "OFF" and then "ON" after checking the belt tensions.	See "CARRY THROUGH BELTS" on page 5-1.
	The compression belt tension is too great.	Check the tension of the compression belts.	See "COMPRESSION BELTS" on page 5-4.



**9. RECOMMENDED SPARE PARTS LIST**

Part Number	Description	Spare Qty. Recommended
17033	FUSE - 0.5 A, FNQ-R, TIME DELAY	2
17178	KIT - SOLENOID, VALVE, 24 V	1
17376 <sup>1</sup>	HEATER, 3000W, 460V-ONLY, OPEN-ELEMENT	2
17375 <sup>2</sup>	HEATER, 3000W, 230V-ONLY, OPEN-ELEMENT	2
17423	BELT - TIMING, W/COATING (COMPRESSION)(300H300)	2
17453 <sup>3</sup>	BELT - CARRIER, PBC, STANDARD	2
17953 <sup>4</sup>	BELT - CARRIER, PBC, EXTENDED	2
17782	INSULATION - END, MANIFOLD, FELT, 1-3/4	1
67297 <sup>1</sup>	FUSE - 10 A, KTK-R-10, 600 V, CLASS CC	5
67816 <sup>2</sup>	FUSE - 15 A, KTK-R-10, 600 V, CLASS CC	4
67312	CONTROL - TEMP, 24 V, 1/32 DIN	1
67329	FUSE - 2.5A, 5 MM X 20 MM, 250 V	1
67706	SENSOR - AIR FLOW, CHEM-TEC 375	1
67823	RELAY - SOLID STATE, 20 A, 600 V	1
67911	THERMOCOUPLE - J TYPE, 5-3/16" T X 7" L	1

<sup>1</sup> USED ON 460V-3PH & 380V-3PH SUPPLY MACHINE

<sup>2</sup> USED ON 230V-3PH & 230V-1PH SUPPLY MACHINE

<sup>3</sup> USED ON MACHINE WITH STANDARD LENGTH MANUAL OR AUTOMATED INFEEED

<sup>4</sup> USED ON MACHINE WITH EXTENDED LENGTH AUTOMATED INFE