



LAB-1100

Inline Automatic Wrap-Around Labeler

Operation Manual



866-888-6327

sales@clevelandequipment.com

4403 Delp Street

Memphis, TN 38118

www.clevelandequipment.com



Table of Contents

1 SAFETY INSTRUCTION	3	7 OPERATION	48
1.1 About the Manual	3	7.1 Start	48
1.2 Safety Guidelines.....	4	7.2 Speed Adjustment	49
1.3 Warning Plate.....	11	8 MAINTENANCE	51
1.4 Location of Safety Signs	13	8.1 Safety Rules for Electrical Control System..	51
2 INTRODUCTION	14	8.2 Regular Maintenance.....	52
2.1 Machine Introduction.....	14	8.3 O-ring Replacement.....	53
2.2 Specification.....	15	9 TROUBLESHOOTING.....	54
2.3 Name Plate.....	16	9.1 Out of Power	55
2.4 Machine Orientation	16	9.2 No Reaction.....	56
2.5 Machine Dimension Drawing	17	9.3 Failure to adjust speed	56
3 MACHINE POSITIONING.....	18	9.4 Dispensing Continuously	57
3.1 Lifting the Machine	18	9.5 Failure in Dispensing.....	57
3.2 Installation and Level Calibrations	18	9.6 Crumple Labeling.....	57
3.3 External Power Connection	18	9.7 Inaccurate labeling	57
4 PRODUCT DESCRIPTION.....	19	9.8 Control Panel Shows “HELP”	57
4.1 Components.....	19	9.9 Lopsided Labeling	58
4.2 Control Box.....	22	10 ELECTRICAL DIAGRAM	60
5 LABEL THREADING	28	11 REPLACEMENT PARTS	61
5.1 Threading	28	12 PART LIST	62
5.2 Label Roll Replacement	34	12.1 Labeling Applicator	64
6 ADJUSTMENT	37	12.2 Control Panel and Conveyor.....	66
6.1 Labeling Height.....	37	12.3 Wrapping Unit	67
6.2 Wrapping Belt Position.....	38	13 APPENDIX	68
6.3 Guide Rail	39	13.1 Fuse Replacement.....	68
6.4 Wrapping Plate Position	41	13.2 Label Length Checking Setting.....	70
6.5 Sensor Adjustment	44	13.3 Clear Label Sensor Setting (Optional)...	71
		13.4 Printer Setting (Optional)	74



1 SAFETY INSTRUCTION

1.1 About the Manual

For the user to become familiar with this product and its mechanisms, this manual provides detailed product descriptions. Observe the explicit operating instructions with care. If any instructions are unclear, we advise that the user contacts us; otherwise, inexperienced handling may cause damage to persons or property.

Note: Before installing or operating this product, we highly advise the user to read this manual. Pay close attention to the possible hazards to both the operating personnel and the machine to ensure the safest and most correct way of operation and usage.



1.2 Safety Guidelines

This product is a heavy-duty machine meant for use in production settings. Take all safety precautions seriously to avoid bodily harm to employees and damage to the machine.

Taking precautions can significantly minimize the number and severity of unforeseen accidents. All employees must be aware of the potential hazards of the machine.

Operators must be able to use the machine safely and responsibly to protect themselves and the employees around them and should be provided adequate training and tools to do so on the organization's part.

WARNING



Do not wash or splash water on the machine. May cause machine malfunction or electric shocks.



Do not wash electric parts, plugs, and cables. May cause machine malfunction or electric shocks.



- Our machines are either 110 or 220 VAC, unless specifically customized. The outlet voltage should fit the power standard of the machine and should always stay within the security limit. Any human contact with high voltage energy may result in injury or death to personnel.
- Do not make adjustments to the running machine unless it is necessary. Failure to follow this warning may expose the operator to danger. Only engineering technicians or other qualified personnel should be making any adjustments to the equipment to minimize risk.
- Do not place the machine in high-temperature environments or near inflammable materials of any kind.
- The machine should be placed only on stable platforms or on lower platforms to minimize the risk of equipment falling and injuring personnel. We are not responsible for any damage to equipment that has been set up or placed in a position deemed to be precarious to the machine.
- Do not place the machine in a humid environment or where there may be wet surfaces to prevent the risk of electric shocks.
- Do not attempt to remove/replace parts or use the machine for any other purpose other than recommended. We always recommend the best machine for the samples given to us. The machine we recommend might not be able to handle an unexpected product.
- Do not apply any sort of lubricant except where specified by the instructions. Applying lubricant to unintended places may cause buildup, electrical damage, or clogs in the machine, for which we will not be held liable.
- Do not climb, sit, or engage in horseplay on the machine to avoid injury and damage. Any damage caused by such activities relieves us of any liability.
- Do not operate the machine if:
 - Distracted
 - Under the influence of alcohol or drugs
 - Unable to fully concentrate on the task at hand in any way



- If the operator cannot perform duties properly, shut down operations until a suitable and capable replacement is found
- Be mindful of hair, neckties, loose clothing, fingers, or anything that might catch in the machine during operations. Wear appropriate clothing when operating the machine, and keep hair up if needed.
- If clothing or hair gets caught in the machine, stop the machine immediately; if unable to do so for any reason, immediately remove the article in question to avoid permanent physical damage.
- Keep the machine clear of dirt, debris, dust, oil, or other foreign objects to avoid damaging the machine or products and injury to personnel. If a significant amount of buildup accumulates on the machine, clean it before use.
- In case of fire, use a recommended fire extinguisher for electrical fires. Do not use water to put out an electrical fire, as it may conduct electricity and cause electrocution of personnel.
- Do not touch or open up the control box with wet hands.
- During maintenance, ensure that all operators understand not to use the machine.
- Pay attention to the warning stickers on the machine.
- Do not modify the machine unless recommended by manufacturers, as doing so may compromise the structural integrity of the machine and cause injury to the users.
- Keep this manual where all operators can easily find and use it. In case it is lost or damaged, request a new copy.
- Clean any oily or wet floors to reduce the likelihood of accidents that may occur during operation. The machine may become unstable and injure personnel, or personnel may slip on the wet floor and injure themselves against the machine.
- If the machine overheats due to prolonged use, switch off the power immediately. Do not approach the machine until it has had a chance to cool down.



- Do not obscure or remove any warning labels, and replace those that are no longer legible. Do not use solvents when cleaning them or scrub them off.
- Do not wear gloves when operating the machine unless circumstances deem it necessary.
- The machine must be regularly maintained according to the manual and only by qualified personnel.
- Do not operate the machine in a poorly lit area. Use in places where the operator can see the machine and its workings without difficulty.
- Do not transport the machine without proper and adequate moving equipment. Ensure that the planned travel route is clear of debris and that employees in the vicinity are aware of it. All passages must be wide enough to allow the machine to pass through.
- When moving the machine, move at a slow pace to reduce accidents.
- When moving the machine, remove all removable parts, and stabilize all moving parts to avoid damage.
- Ensure that the emergency stop button is working before operating.
- When setting up the machine, ensure that unrelated people are a safe distance away to reduce distractions and accidents.
- Do not insert objects other than the intended products. Using foreign objects in the machine may cause damage to the machine and injury to personnel.
- It is recommended for the operator to wear non-slip shoes while using the machine.
- If there is a strong burning smell suspected to come from the machine, cut power immediately and leave the area until safety personnel gives the all-clear.



- When operating the machine, please do so professionally and carefully. Clear the immediate area of non-essential personnel if possible.
- Manually test each feature of the machine before operation to catch any issues.
- Replace parts with approved parts to increase machine life.
- Different environments, such as high temperatures or low humidity, may cause a longer or shorter product lifespan. Replace parts accordingly, and try to ensure a stable environment for the machine if possible.
- Ensure that when multiple people are working on the same machine, they do not interfere with each other's work.
- Keep sharp objects away from the machine to avoid scratching and damage to the surface.
- Keep young children and animals away from the machine.
- Use only approved cleaners to avoid damaging the stainless-steel surface of the machine.
- Properly store the machine in a dry, cool place when not in use to increase product life.
- All operators should know the basics of the machine and have read this manual before operating it.
- When new operators are learning to operate the machine, they should be under the supervision of experienced operators at all times.
- Use the proper tools when assembling or disassembling the machine to avoid damage and difficulty in future maintenance.
- Keep a proper record of all maintenance, changes, and replacements to the machine for future references. If there are any records of non-approved parts, remove and have them replaced by approved parts as soon as possible.



- If there are strong and unidentifiable odors coming from the machine, disconnect the power and leave the immediate area until it is clear that there is no danger.
- Suppose there is no way to conduct maintenance without the machine being live. In that case, a second person must be on hand and ready to hit the emergency stop button at a second's notice.
- Do not try to insert fingers into valves or nozzles, especially when the machine is on.
- Do not put pressure on the machine while the machine is on.
- Please do not eat or drink near the machine to avoid crumbs and liquids falling into it.
- Please do not leave the machine wet as it may rust.
- When receiving the machine, check if there is any physical damage to the crate.
- The machine should be unplugged when performing maintenance and not just switched off.
- Do not strike the machine as it has many sensitive parts.
- Do not run near the machine.
- If any settings need to be adjusted, ensure that the machine has completely stopped and remove remaining products.
- Do not submerge the machine in any liquid.
- Do not use the machine near an open flame.
- Make sure the machine is on an even surface and that the feet are locked.
- Make sure that no small pieces are missing and that all pieces are secure.
- Be careful not to trip over wiring.
- Do not block any monitors or sensors, as it may cause the machine to work improperly.



- Do not use the machine if there is a visible defect or broken parts.
- Ensure air and energy supply are steady.
- Do not attempt to increase or decrease the air pressure outside of the recommended limits.
- Keep work area clean.
- Do not leave the machine unattended.



1.3 Warning Plate

- **General**

This machine has warning symbols attached to it, as shown below, to ensure proper and safe operation. These symbols are used on the machine to indicate points or instances of specific danger to operating personnel.

Make sure to memorize these symbols and bring them to the attention of others as and when necessary. Do not remove safety symbols from the machine.

	<p>Risk of electrical shock! Failure to observe will put your life in danger. Enclosures which do not clearly show that they contain electrical devices are marked with the warning sign on the left.</p>
	<p>Do not touch! Failure to observe could result in loss of fingers or other body parts. The prohibition sign on the left indicates a risk of personal injury in the area where the prohibition sign is placed.</p>
	<p>Be Careful the machine is stopped! Failure to observe could result in damage of fingers or other body parts. The prohibition sign on the left indicates a risk of personal injury in the area where the prohibition sign is placed.</p>
	<p>Emergency stop Failure to observe could result in further damage and injury. The emergency stop button is to stop the machine whenever there is a dangerous accident.</p>



- **Incorrect use of the equipment will put your life in danger!**

We will take no responsibility for any fatal accidents, injuries to personnel or damage to the machine if the machine or associated equipment is installed, operated, and serviced without following the instructions in this manual.

- **Risk of immediate danger to life!**

Never inch or run the machine if any safety components included in the safety system is non-operational. Non-operational safety components must be changed immediately.

Notice of Equipment Improvements & Document Revisions:

We are devoted to developing and researching new techniques and products and reserves the right to change or terminate the specifications and features which are presented in this manual without notice and without taking any responsibilities for any issues caused by such adjustments. We strive to provide all necessary information about the product in this manual, but also reserve the right to correct any mistakes in future revisions.



1.4 Location of Safety Signs

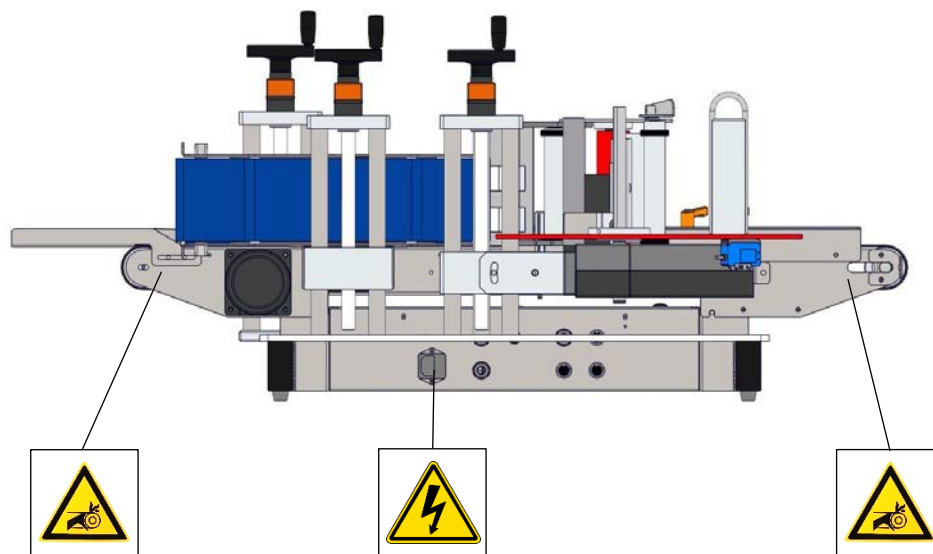
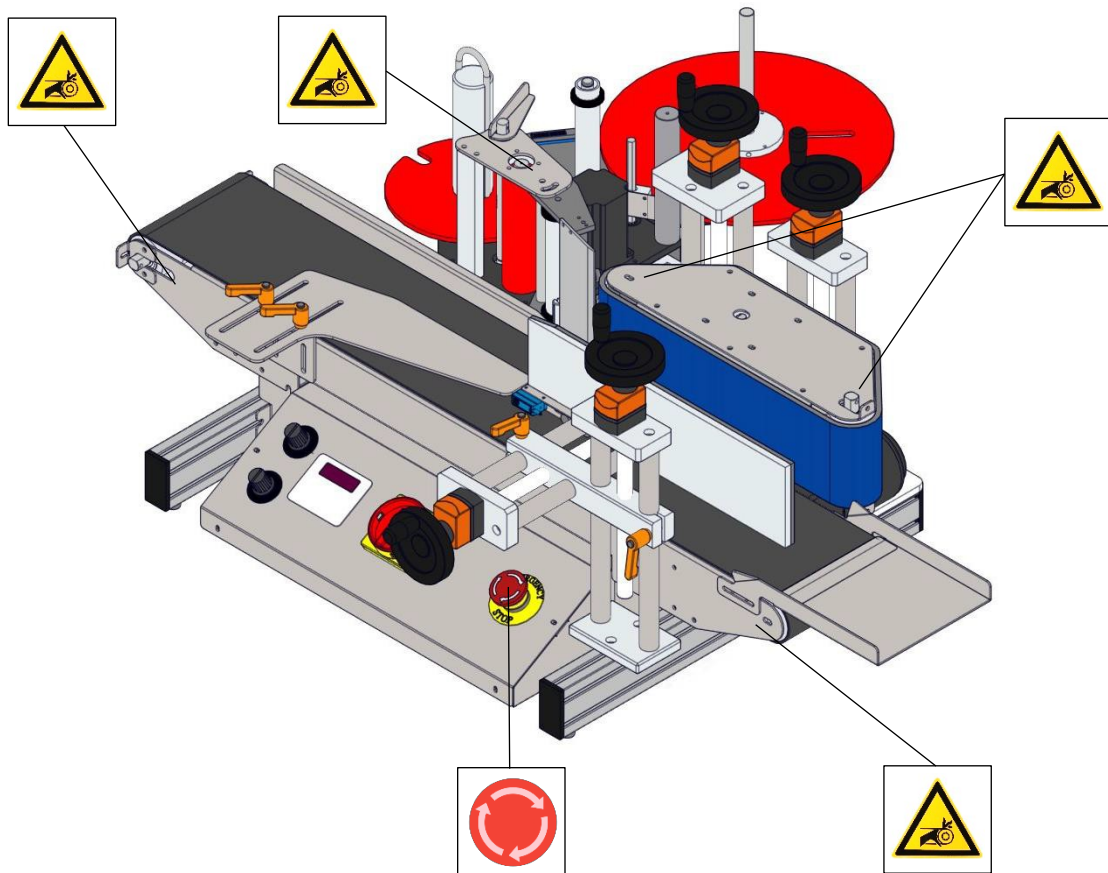



2 INTRODUCTION

2.1 Machine Introduction

The LR1100 is a versatile machine applicable to cylindrical containers in the food, pharmaceutical, chemical, and cosmetics industries. It provides stable, precise, and compact labeling solutions for all sorts of products.

Features:

- Simple to use and custom-made
- Quick and straightforward product changeover
- Use it for a wide variety of products
- Motorized conveyor and wrapping belt with speed controls
- Integrated control panel for easy adjustments
- Microprocessor board preprogrammed, easy to maintain
- Accurate optical fiber sensor for precise dispensing and labeling
- SS304/ Anodized aluminum construction meets cGMP standard
- Suitable for tabletop operations
- Driven by a stepper motor, quiet and smooth



2.2 Specification

Labeling Speed	10 meters/min	
	Around 20 -40 bottles per minute (subject to actual label size)	
Labeling Accuracy	±1mm	
Bottle Dimension	(Dia.)16-90mm ; (H)30-160mm	
Label Dimension	(L)10-300mm ; (W)10-100mm	
Label Roll Diameter	(ID)75mm ; (OD)300mm	
Driven Motor	Stepper Motor	
Power Supply Requirement	110V; 50/60Hz; single phase	
	220V; 50/60Hz; single phase	
Amperage Requirement	2A	
Electric Power	115W	
Power Cable Type (Optional)		Type B; 3.3M
		Type C; 1.8M
		Type G; 1.83M



2.3 Name Plate

MODEL:	SERIAL NO:
POWER:	MFG:

2.4 Machine Orientation

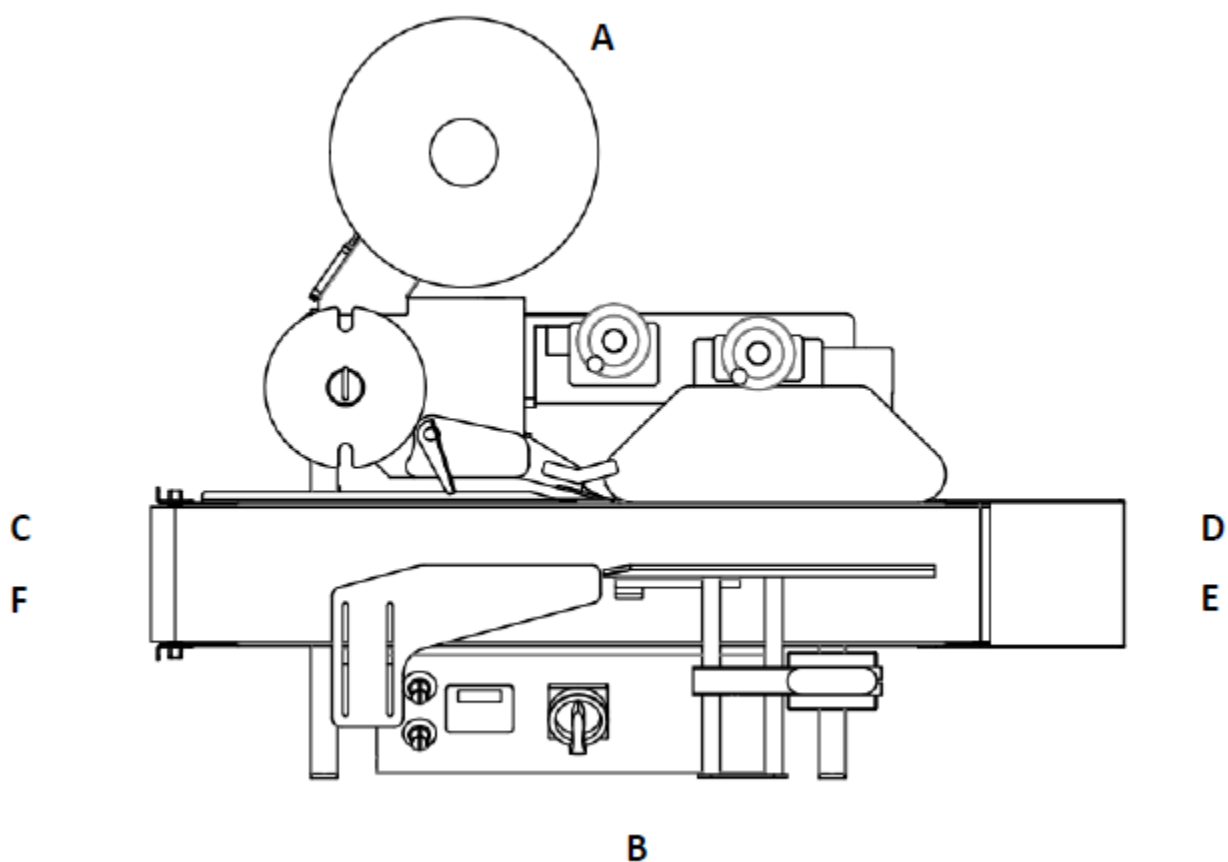

Definition of direction:

The illustration above shows the machine from the **Top**.

A indicates the **Rear** of the machine.

B indicates the **Front** of the machine.

C indicates the **Left** of the machine.

D indicates the **Right** of the machine.

E indicates the **Infeed** of the machine.

F indicates the **Outfeed** of the machine.



2.5 Machine Dimension Drawing

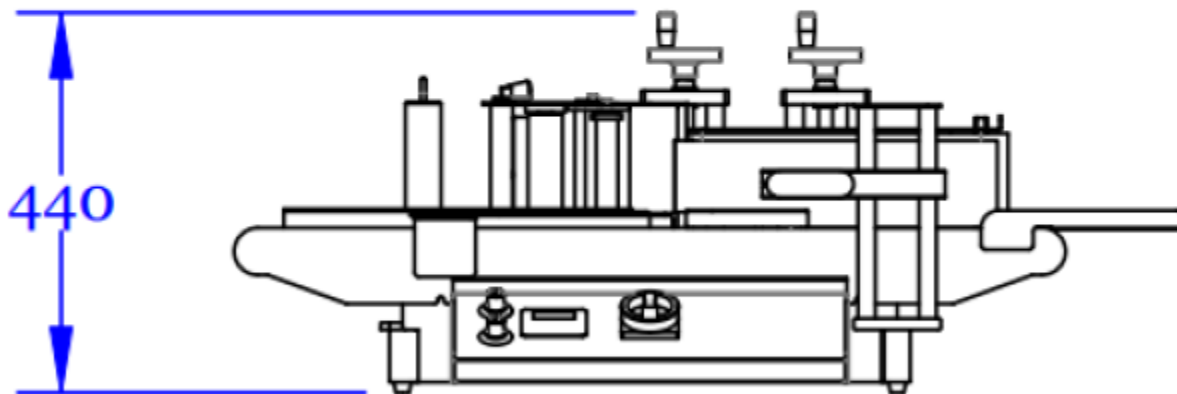
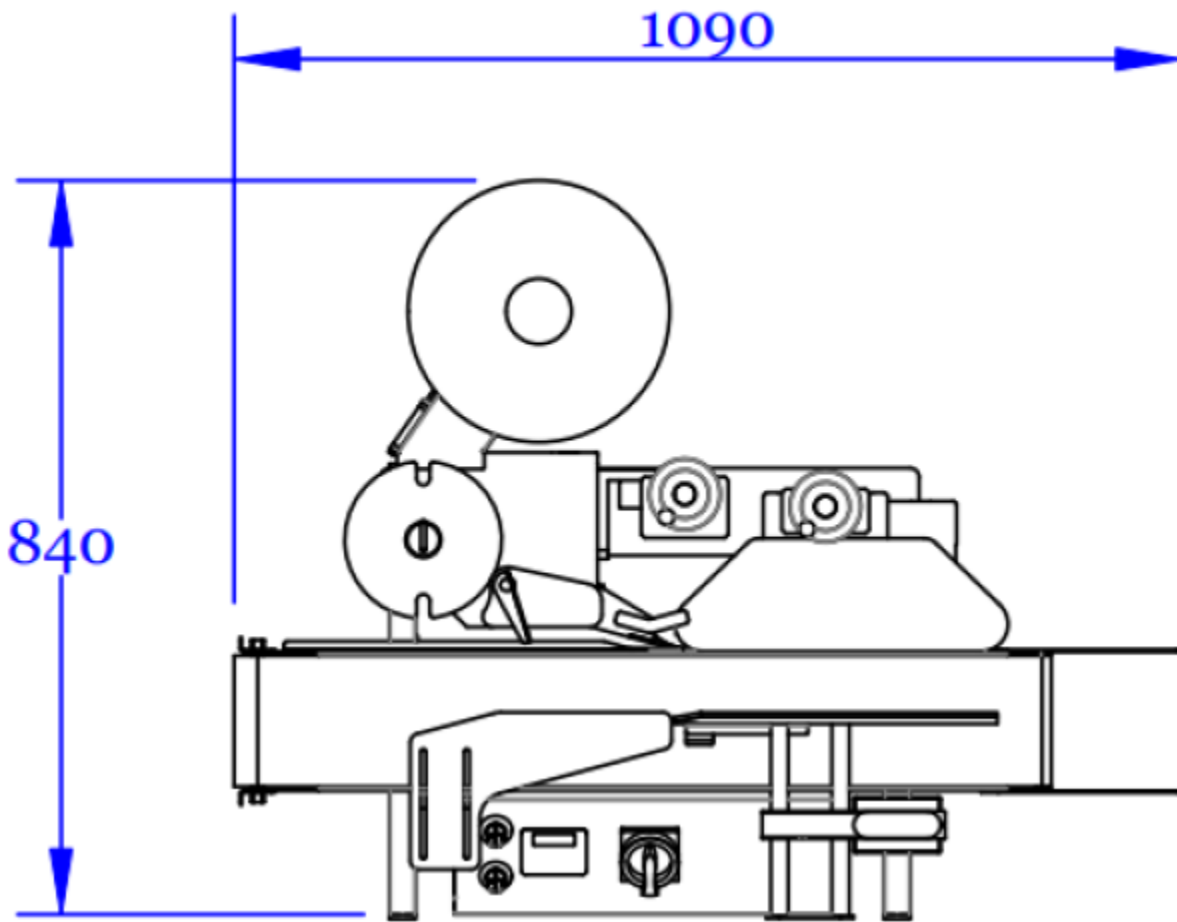

Unit: mm



3 MACHINE POSITIONING

3.1 Lifting the Machine

- 3.1.1 Before unloading the machine, conduct a complete inspection for any damage.
- 3.1.2 Before placing the machine on the production surface, ensure that the base is thick and robust enough to endure mechanical vibrations and support the machine's weight for a long time.
- 3.1.3 Allow enough room around the machine for auxiliary production equipment for the maintenance of the machine.
- 3.1.4 Use haulage equipment with sufficient strength, such as a crane, forklift, wire ropes, and hooks for the machine weight.
- 3.1.5 When lifting the machine, do not attempt to do so alone.

3.2 Installation and Level Calibrations

- 3.2.1 Position machine on any sturdy surface.
- 3.2.2 The surface must be flat and level. Place the machine firmly on it.
- 3.2.3 To connect the machine with another, ensure that the receiving conveyor must be slightly lower than the preceding conveyor.

*When moving the machine, hold firmly onto the metal frame, not the moving machine parts. Do not attempt to move the machine without a partner.

3.3 External Power Connection

- 3.3.1 Before connecting the power wires, make sure the voltage between the machine and your factory power source is the same. The machine must be properly grounded to prevent possible injury from electrical shock.
- 3.3.2 Connect the power wires from the machine to the outlet according to the connector type.
- 3.3.3 Qualified electrical personnel should perform all electrical connections.
- 3.3.4 Check connection of power wires.
- 3.3.5 After connecting wires, tighten the screws.



4 PRODUCT DESCRIPTION

4.1 Components

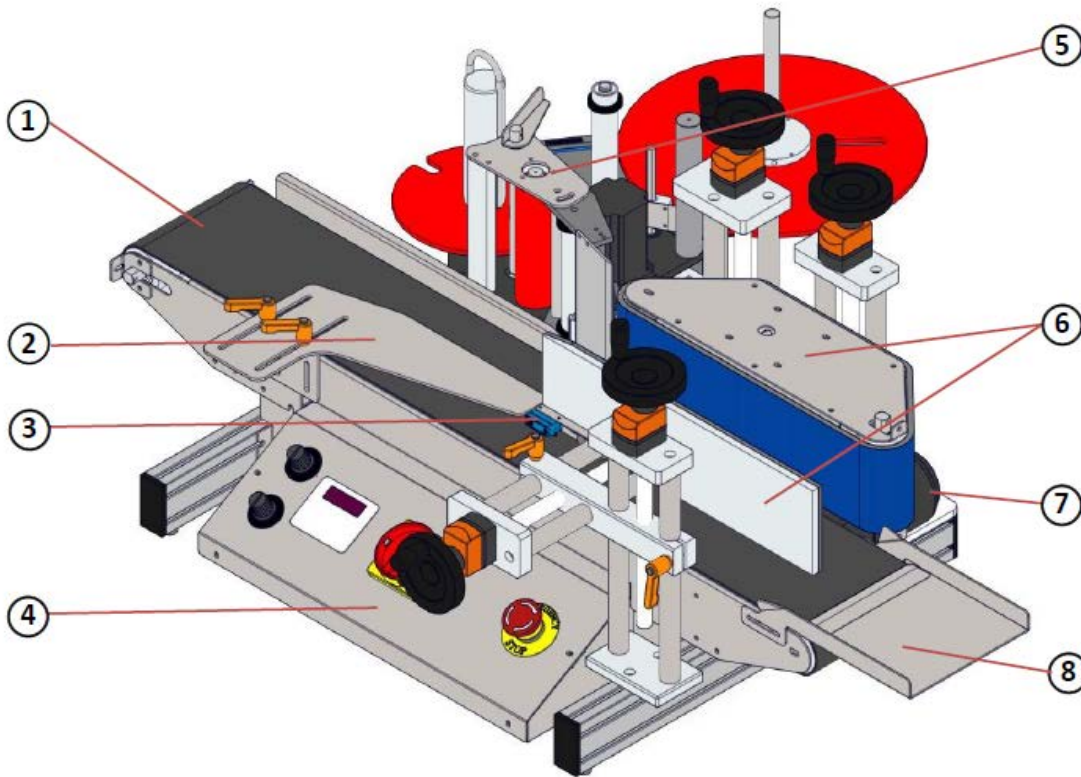

- | | |
|-----------------|--------------------|
| ① Conveyor | ⑤ Label Applicator |
| ② Guide Rail | ⑥ Wrapping Unit |
| ③ Bottle Sensor | ⑦ Motor |
| ④ Control Box | ⑧ Collecting Tray |



4.1.1 Label Applicator

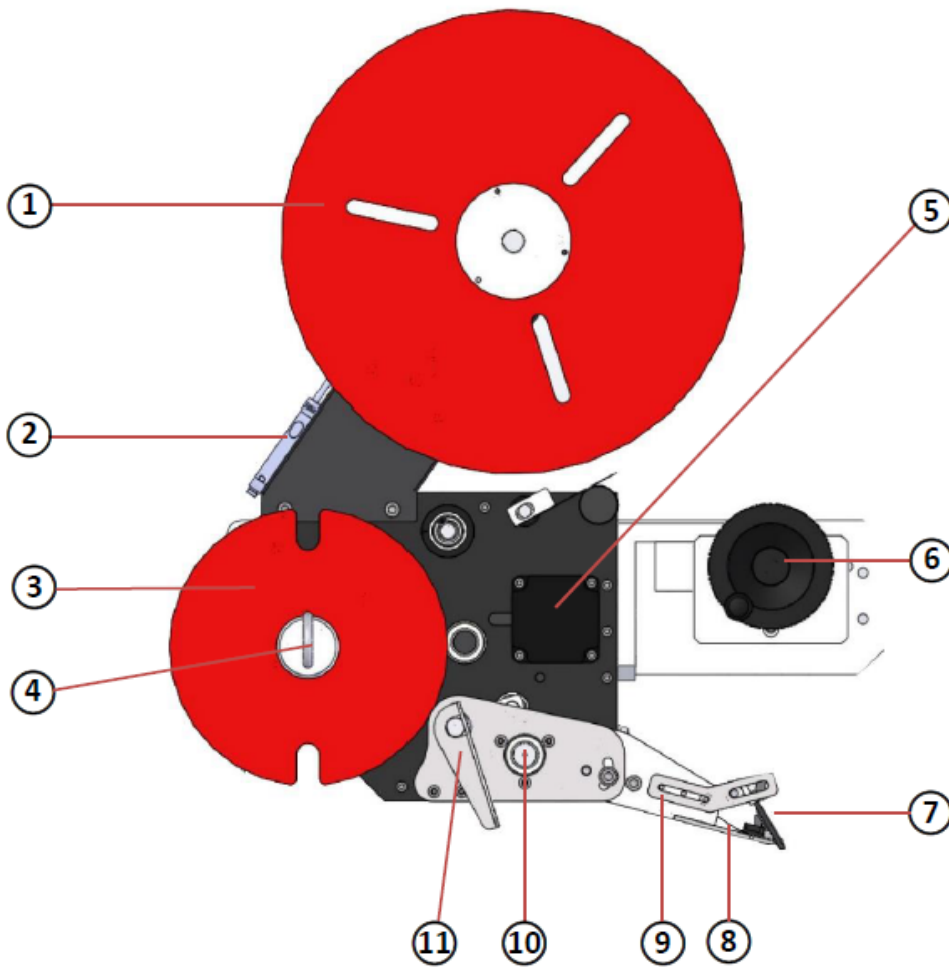

- | | |
|----------------------------|------------------------|
| ① Feed Spool Disc | ⑦ Press Plate |
| ② Amplifier | ⑧ Peel Plate |
| ③ Backing Paper Spool Disc | ⑨ Label Sensor |
| ④ Backing Paper Holder | ⑩ Driving Shaft |
| ⑤ Motor | ⑪ Knurled Drive Roller |
| ⑥ Height Adjuster | |



4.1.1 Wrapping Unit

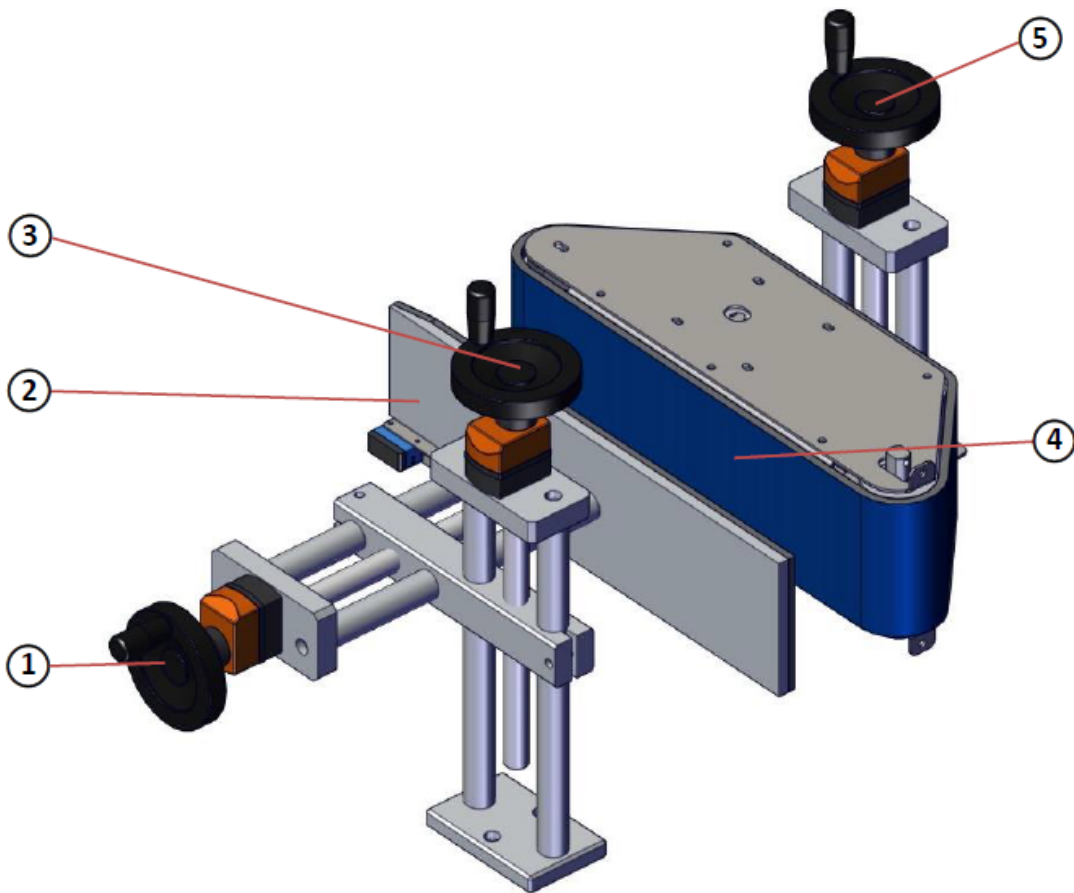

- ① Wrapping Plate Position Adjuster
- ② Wrapping Plate
- ③ Wrapping Plate Height Adjuster
- ④ Wrapping Belt
- ⑤ Wrapping Belt Height Adjuster



4.2 Control Box

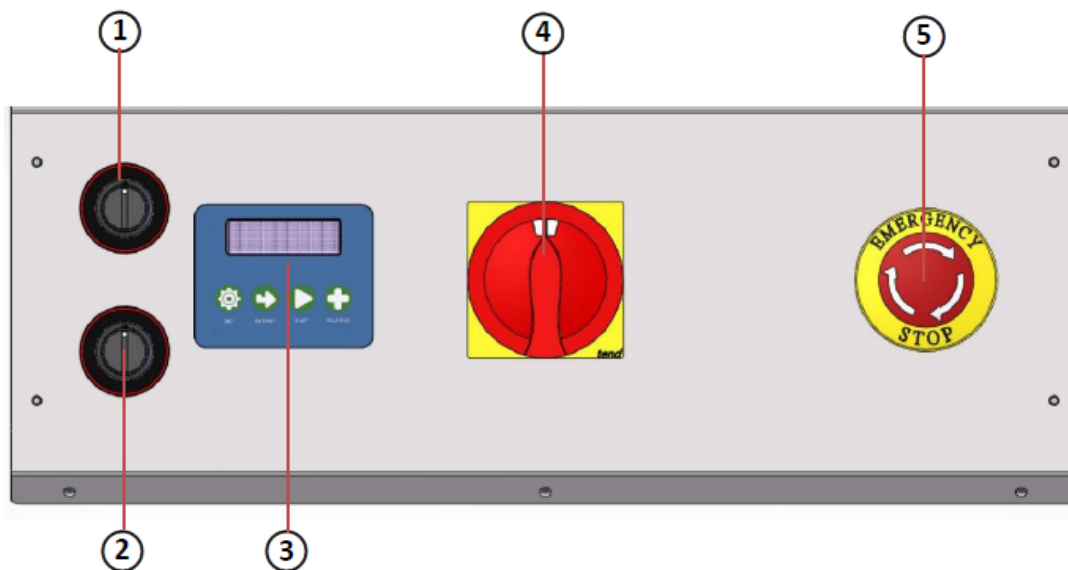

① Rotate Speed

④ Power Switch

② Conveyor Speed

⑤ Emergency Stop

③ Control Panel



① **Rotate Speed**
The speed of the wrapping belt

Speed Up



Slow Down



② **Conveyor Speed**
The speed of the conveyor

Speed Up



Slow Down



③ **Power Switch**
Turn on/off the machine

ON



OFF





4.2.1 Control Panel of Labeling Applicator

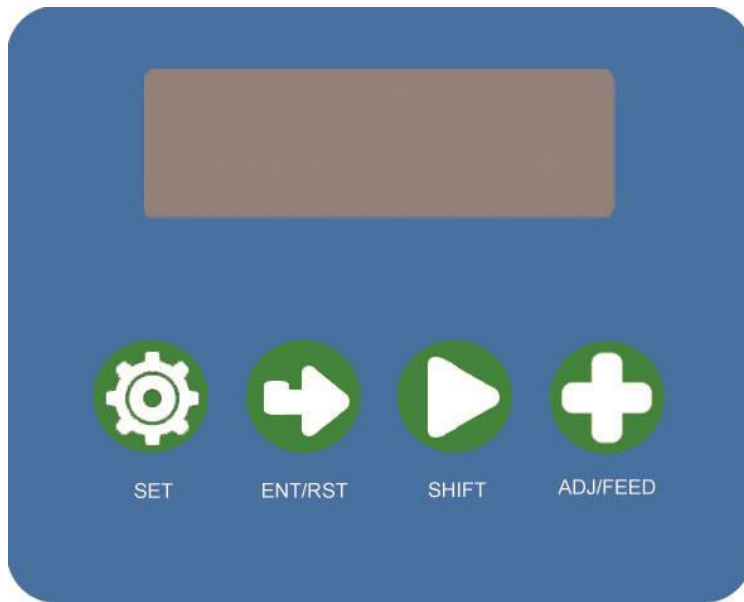

SET

- (1) Press the button to enter the parameter setting page.
- (2) Press this button to pause label dispensing before adjustments.



ENT/RST

- (1) Parameter Choosing: Press the button to choose a parameter to set.
- (2) Reset to Zero: After pressing "SET" to leave the setting page, press



SHIFT

Press this button to shift the flashing cursor.



ADJ/FEED

- (1) Parameter Adjusting: Press the button to increase the parameter.
- (2) Label Dispensing Test: To test label dispensing, leave the setting page and press the button for 3 seconds. The machine will dispense the label once.





4.2.2 Parameter Setting



1P = Labeling Position

Time to delay the start timing of labeling.

- (1) The larger the parameter is, the longer the delayed time will be.
- (2) The initial parameter is 0.001, which means the labeler will work immediately after detecting the product.

* **Note:** The parameter is relative to internal time counting, not absolute time in seconds (ex: 0 does not equal 0 seconds, 1 does not equal 1 second, and so on).

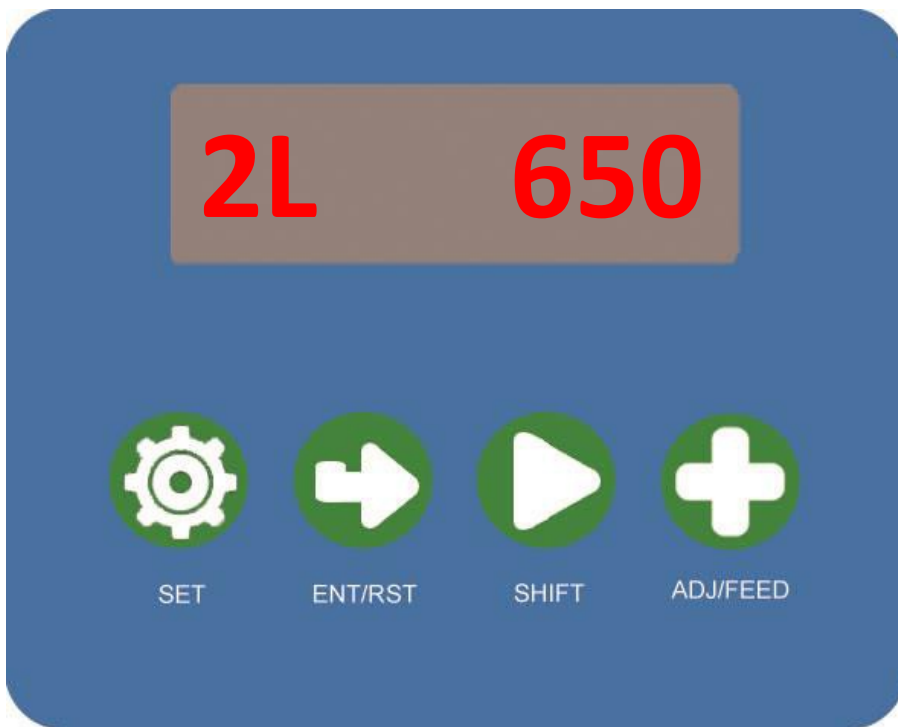
**2L = Label Length**

The machine will dispense a short length of the label before actual labeling.

- (1) The protruding part should attach to the bottle as it starts to rotate.
- (2) If the length of the label is longer than 70mm, set it as 650~750. Otherwise, set as 0.

* **Note:** The parameter is not an absolute length but rather relative to an internal parameter.

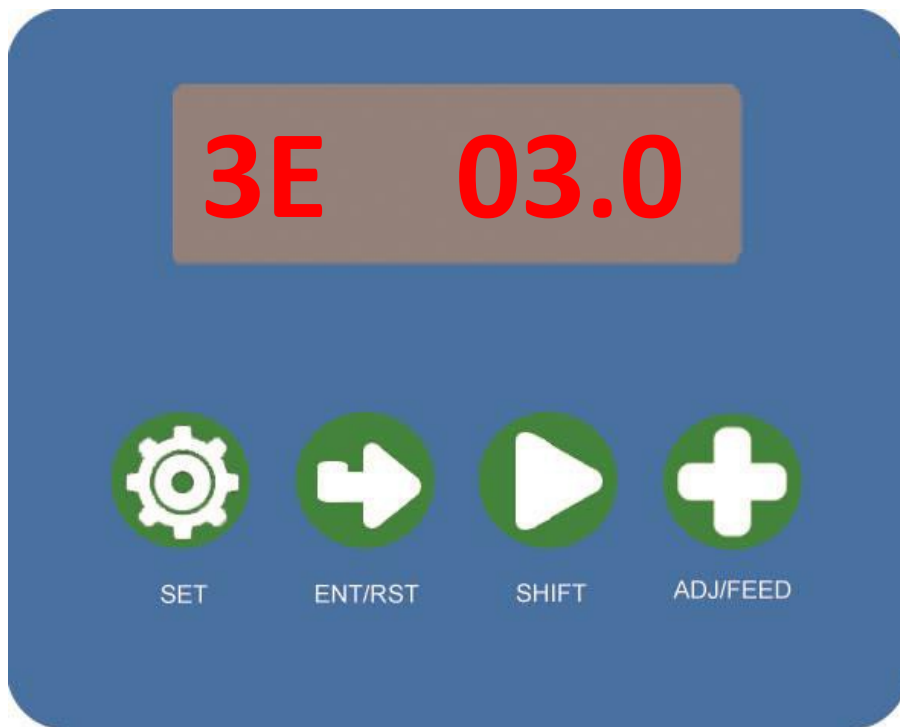

3E = Labeling Speed

The speed of labeling.

- (1) Labeling speed should be the same as rotating speed. To check labeling speed, please view from above.
- (2) If you find crumpled labeling, please decrease the parameter you set. If you find labels dragged out instead of properly dispensed, please increase the parameter.

* **Note1:** The parameter is not the real speed but rather relative to internal parameters.

* **Note2:** Please adjust in increments of 0.1.



5 LABEL THREADING

5.1 Threading

5.1.1 The accuracy of labeling is determined by whether the label threading is correct or not, so make sure the label threading is not curving or loosened. Please follow the steps below to thread the label paper.

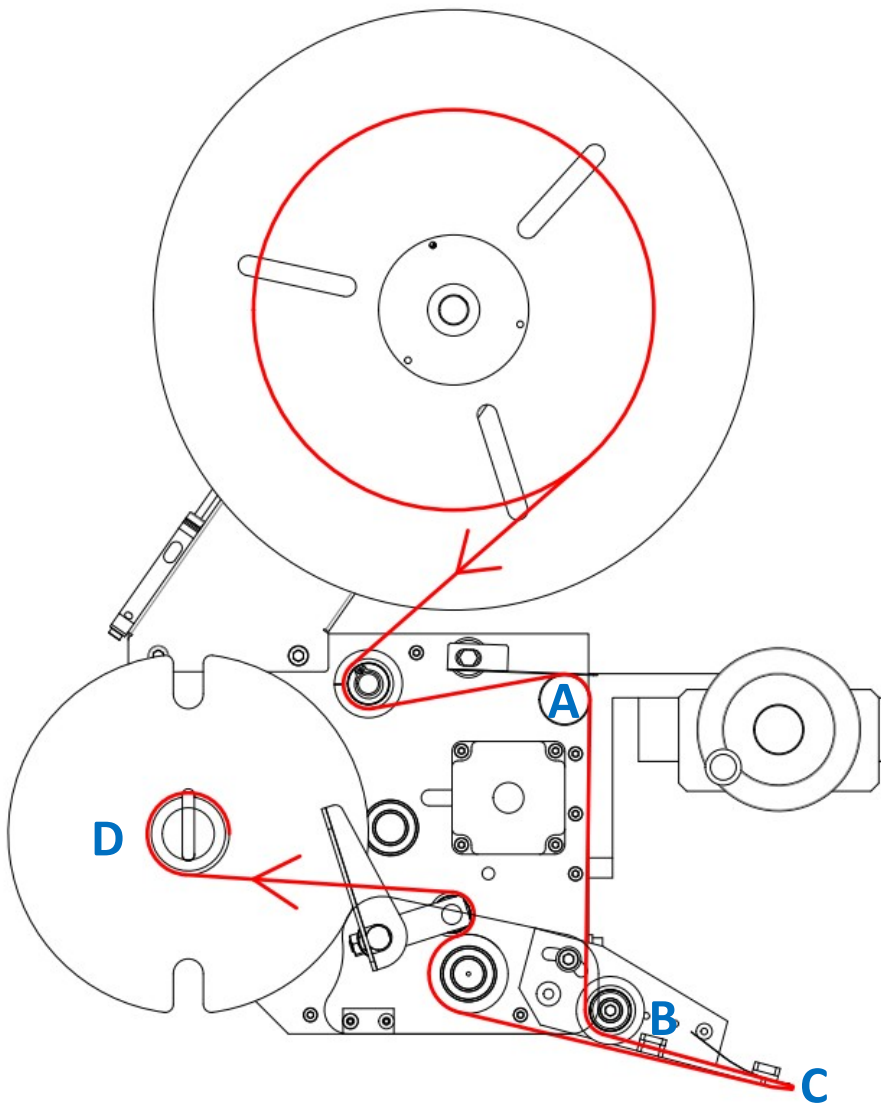

- (1) Place the label roll onto the spool disc.
- (2) Thread to **A**. Make sure the label paper passes through the spring plate.
- (3) Thread to **B** and make sure the label paper goes through the label sensor.
- (4) While threading to **C**, make sure the label passes through the peel plate.
- (5) Thread to **D**, fix the label on the backing paper holder.



5.1.2 Place the label roll on the spool disc.



5.1.3 Thread the label.

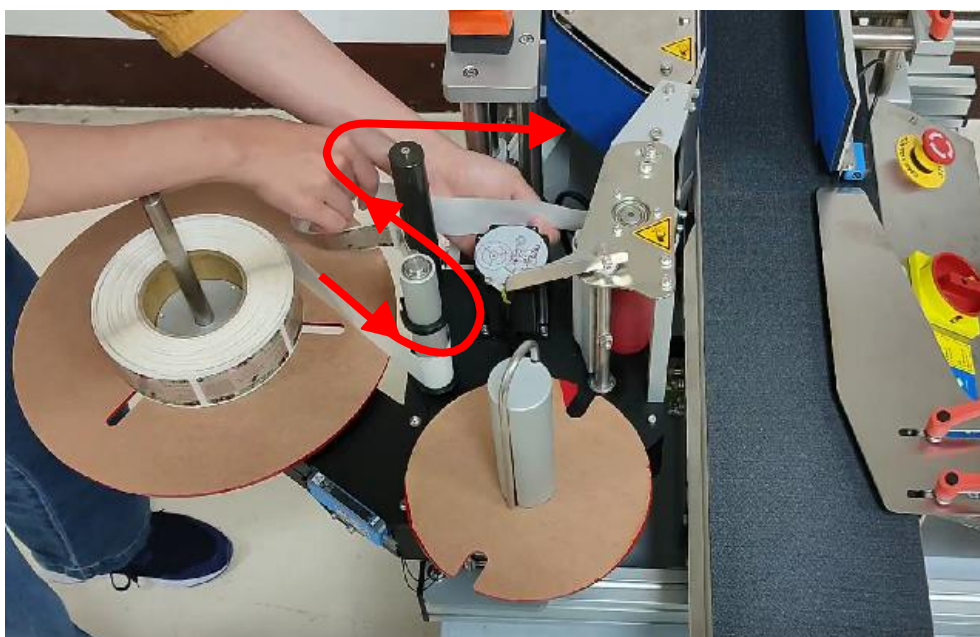



5.1.4 Thread label through sensor and tension plate.

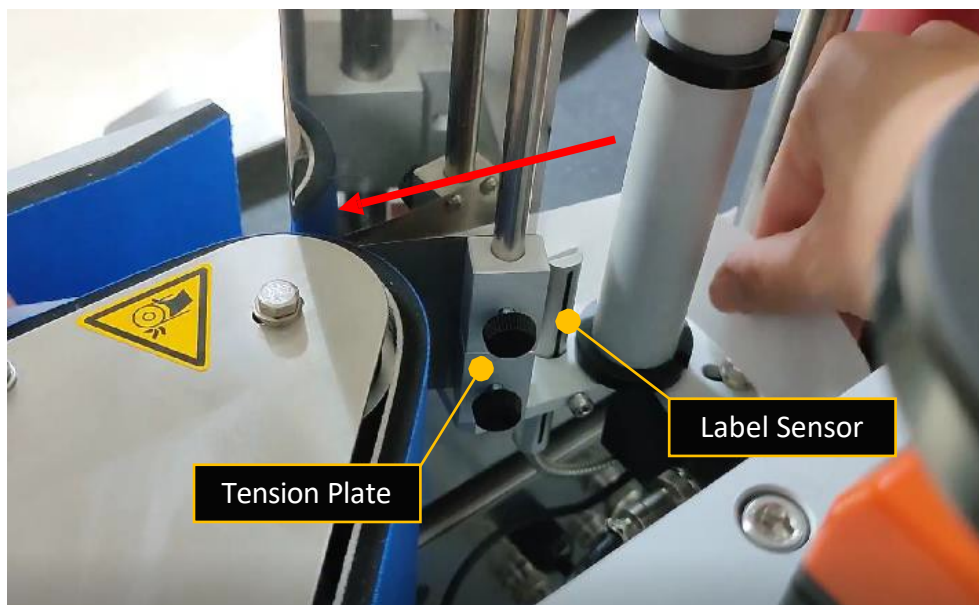

5.1.5 Pull out the label.

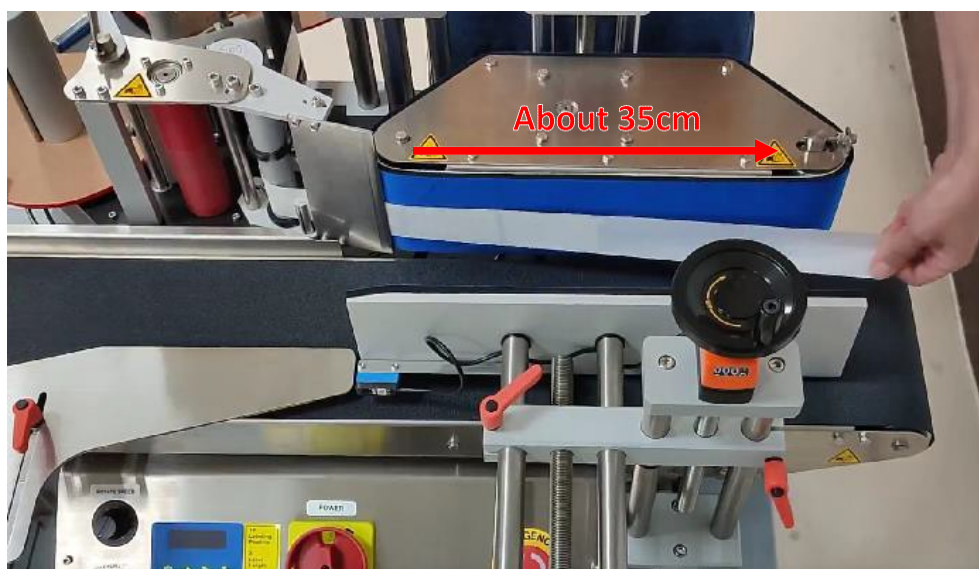



5.1.6 Fold back the label.

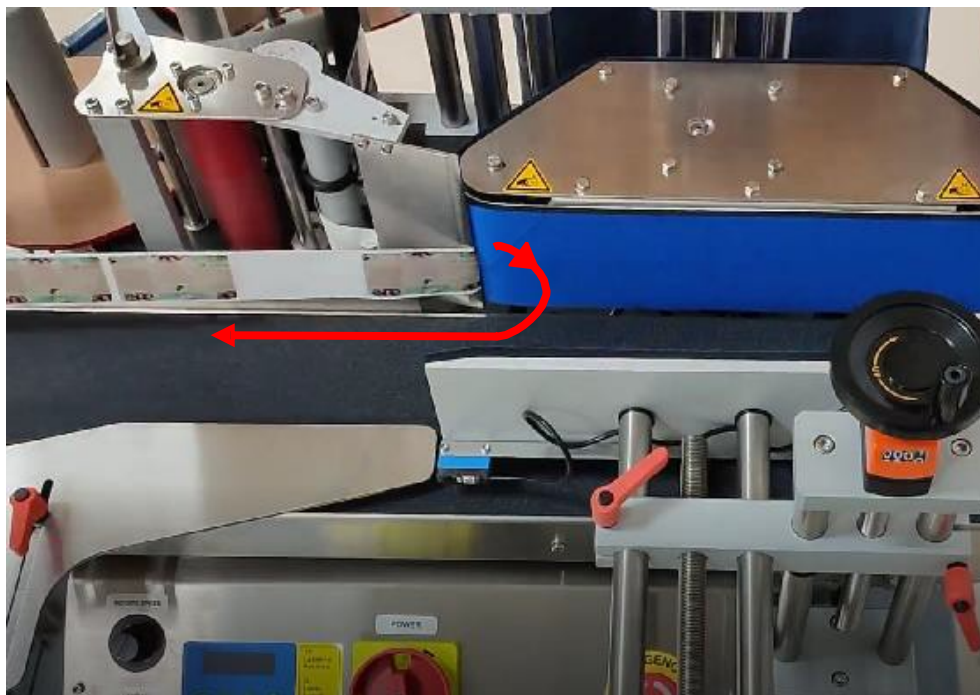

5.1.7 Open the knurled drive roller and thread the label through.

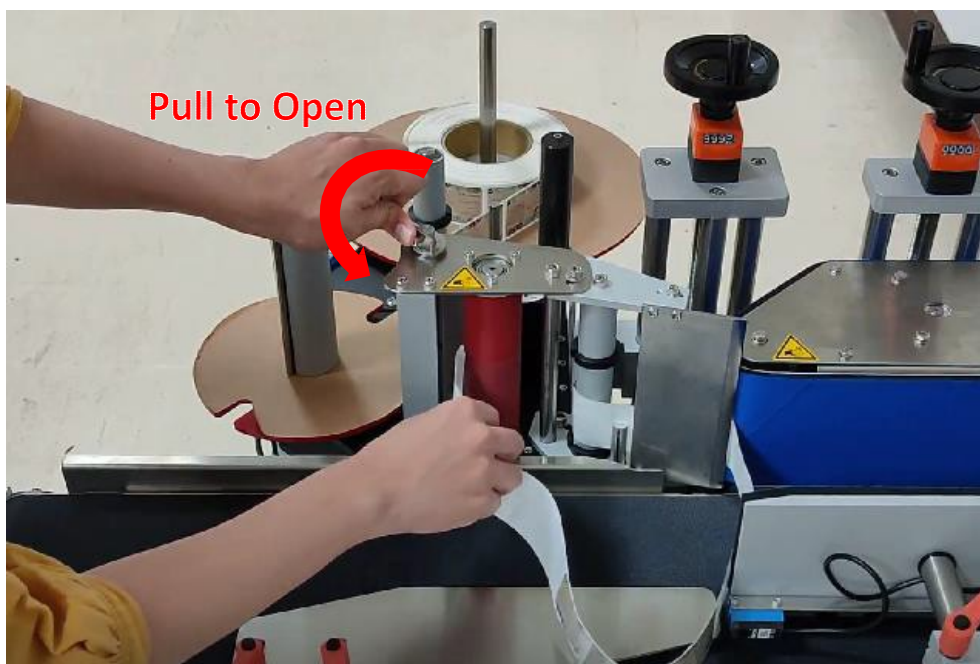



5.1.8 Wrap clockwise around the backing paper holder and replace the pin.

* **Fix the backing paper by clamping one side of it.**

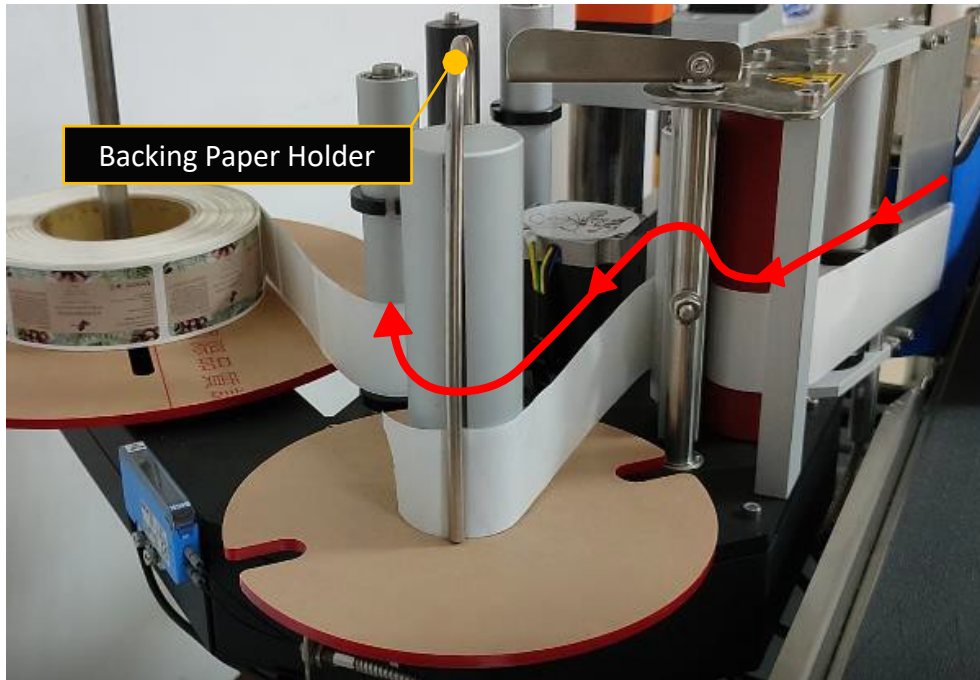

5.1.9 Adjust the guide rings' height to fit the label.

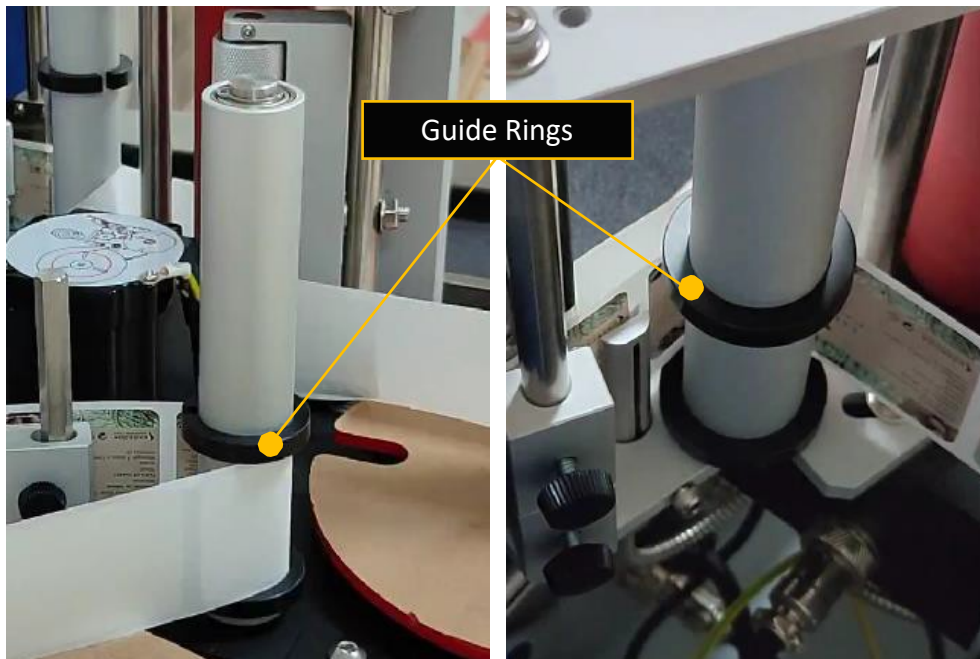



5.1.10 Lock the press plate.

- * If using a larger label, adjust the press plate position to fit the label size. Make sure it is attached to the label.

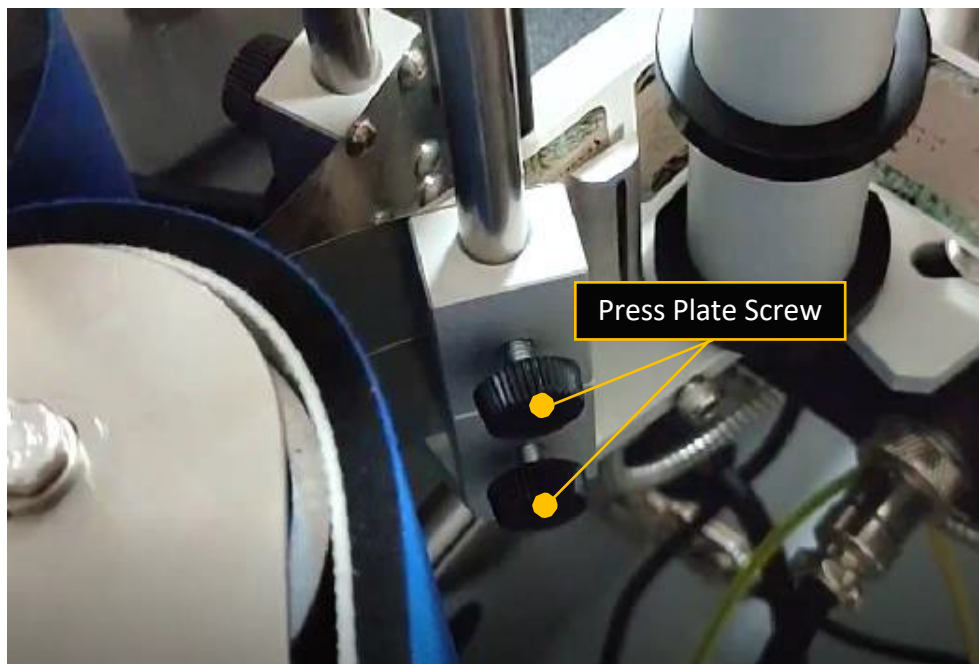

5.1.11 Check that the label is taut and level.





5.2 Label Roll Replacement

5.2.3 Tear the backing paper off at the blue arrow below.

* Do not tear off another part of the label roll to reduce label wasting.

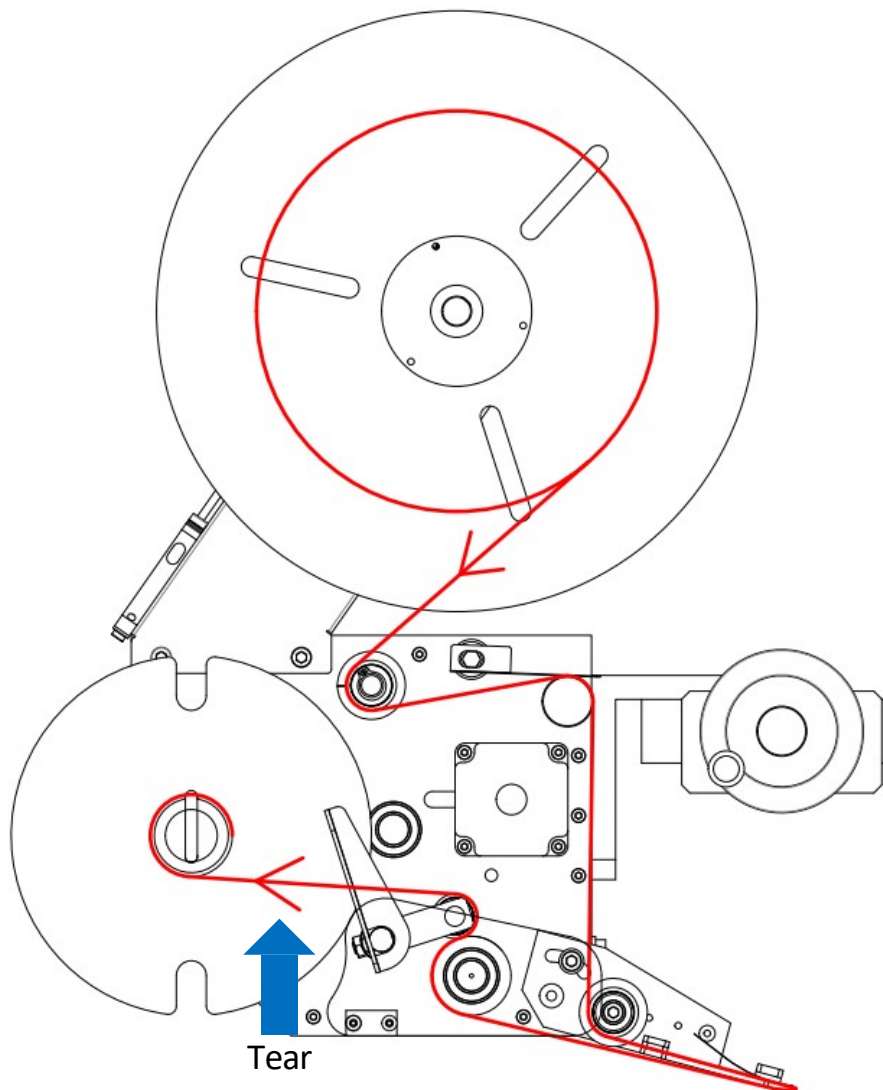



5.2.4 Open the knurled drive roller and pull the label out.



5.2.5 Loosen the tension plate.

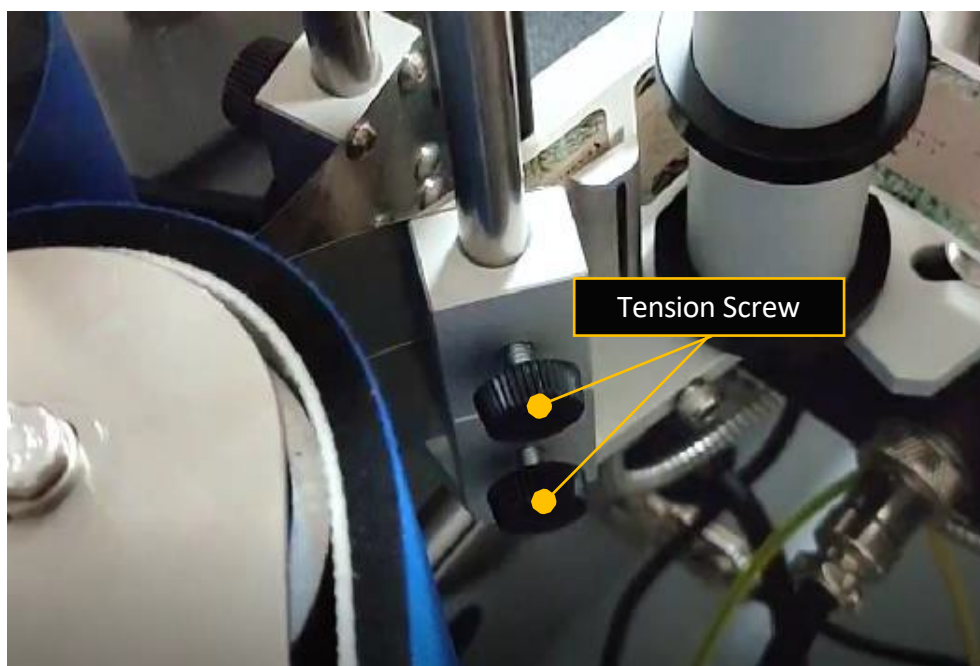



5.2.6 Turn the spool counterclockwise and collect the label.

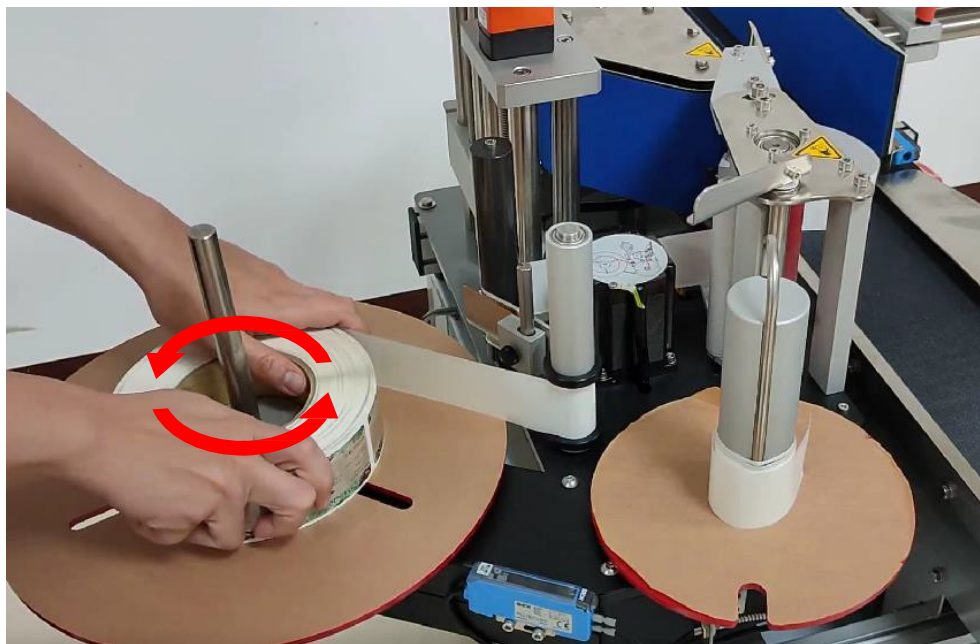

5.2.7 Remove the pin and the waste backing paper.

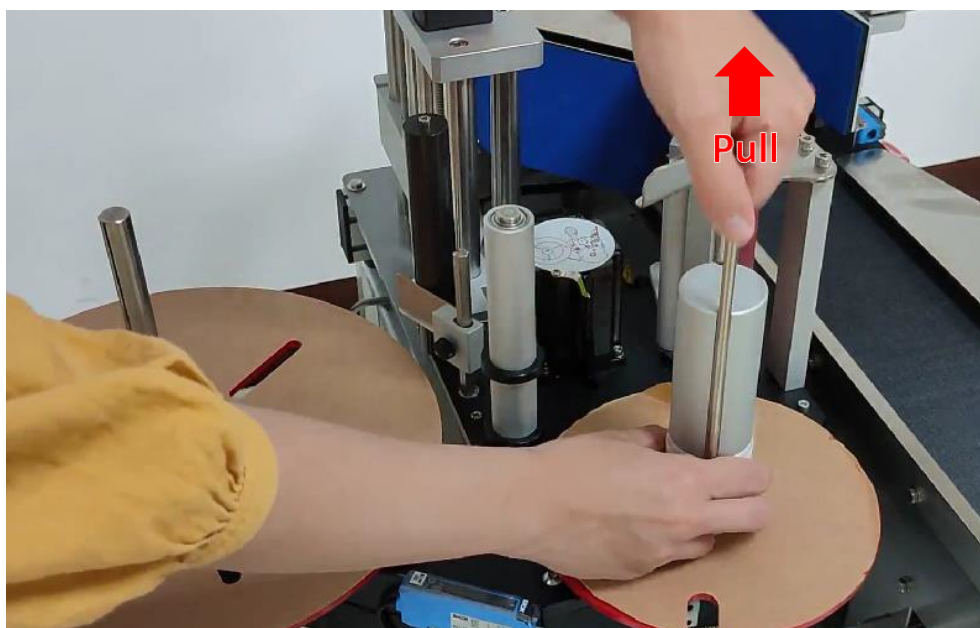



6 ADJUSTMENT

NOTICE: Before mechanism adjustments, please turn off the machine.

If you need to make adjustments while the machine is running, press “SET” to pause labeling.

6.1 Labeling Height

6.1.1 Turn this handwheel to adjust labeling height.



6.1.2 After adjustment, record the parameter on the adjuster for the next time using the same product.

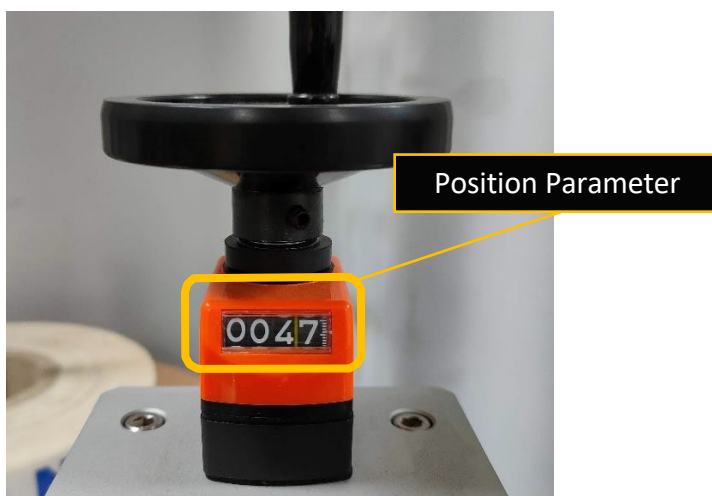



6.2 Wrapping Belt Position

6.2.1 Turn this handwheel to adjust wrapping belt height. Match it to the labeling height.

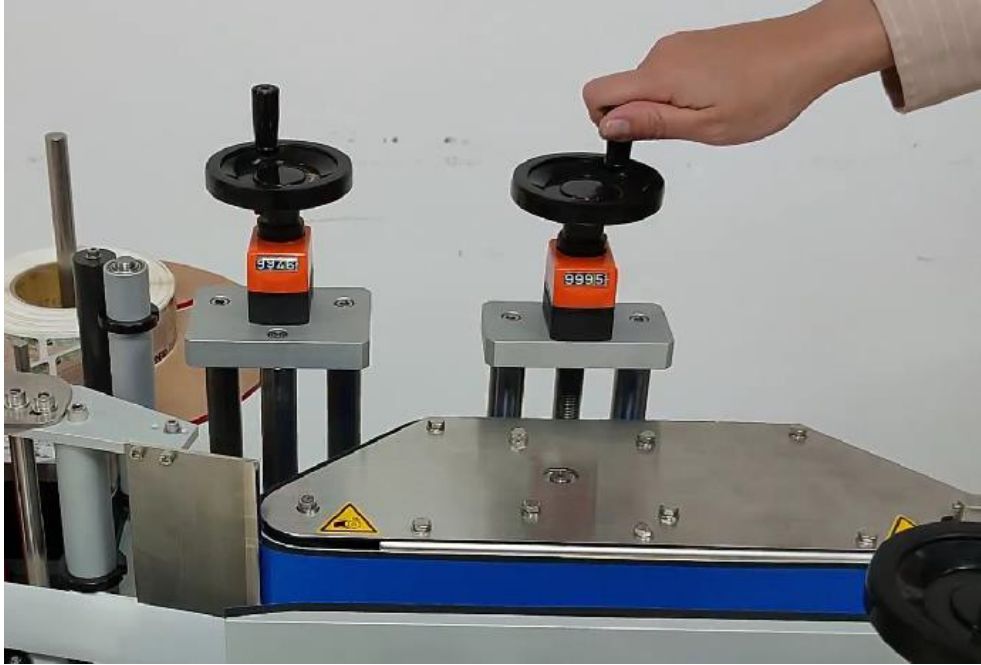

6.2.2 After adjustment, record the parameter on the adjuster for next time.

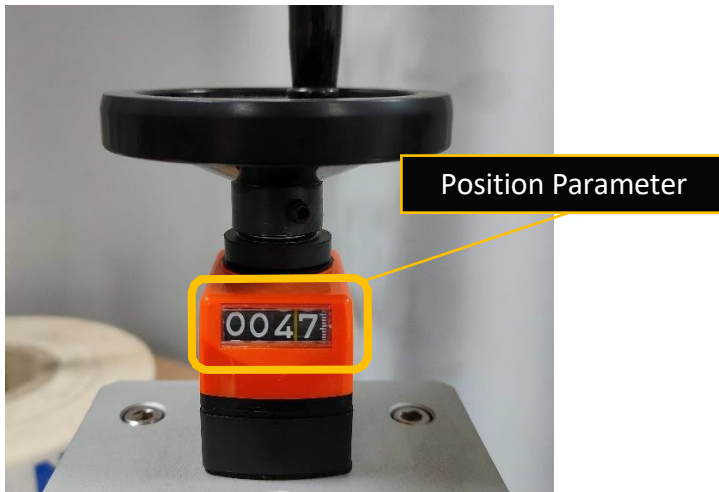



6.3 Guide Rail

6.3.1 Loosen the orange handles.

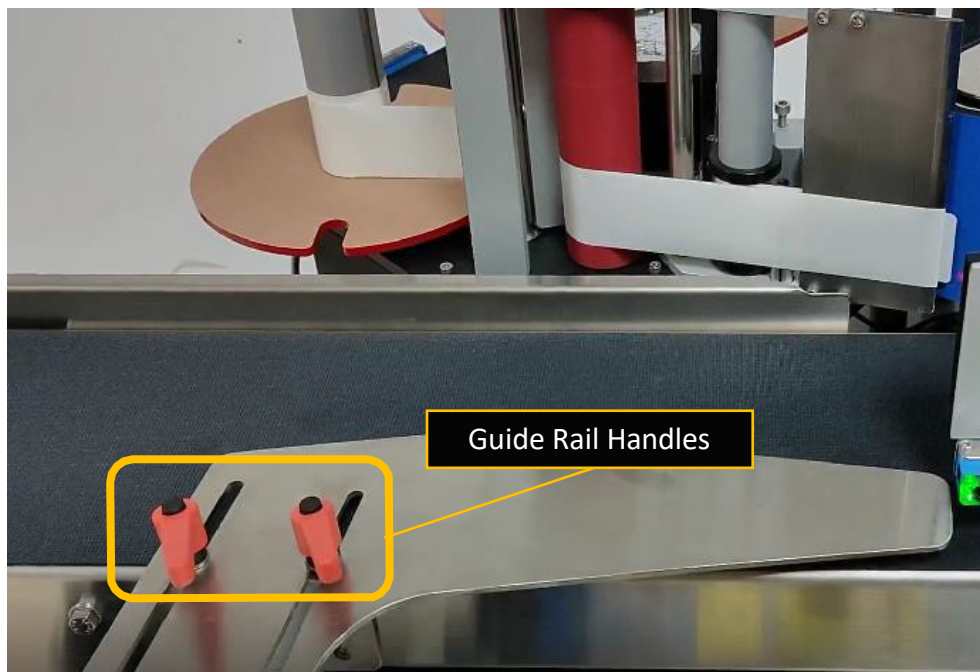

6.3.2 Adjust the guide rail to accommodate bottle size.

Make sure it is wider 1~2mm than the bottle for smooth conveying.

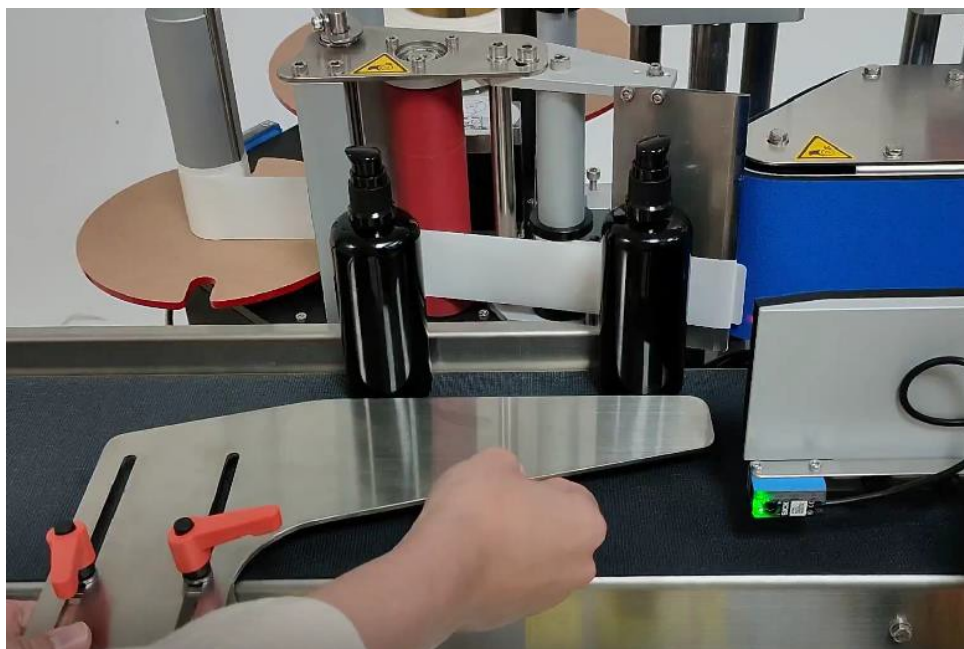



6.3.3 Tighten the handles.

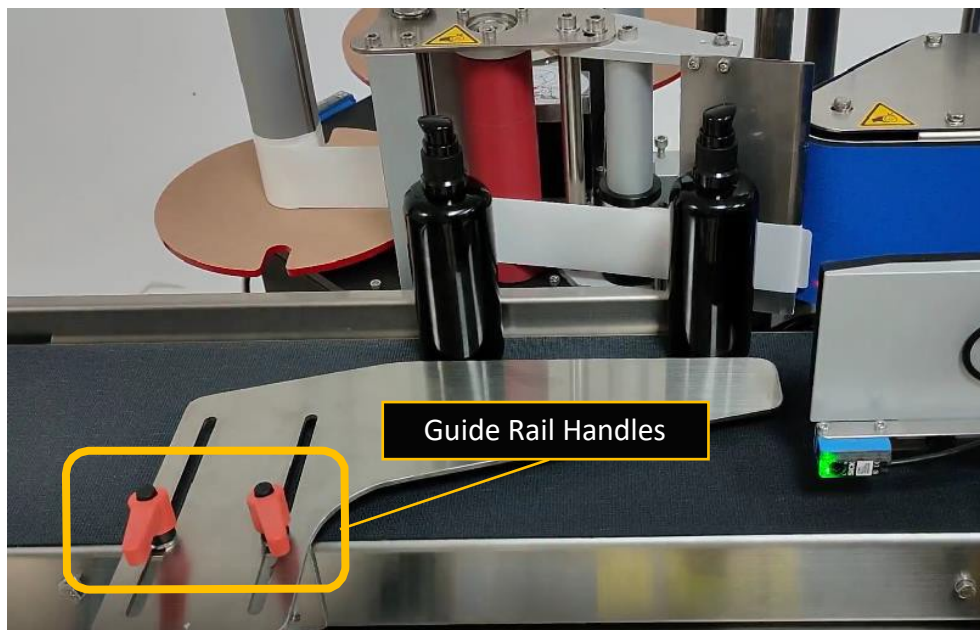

6.3.4 Move the bottle to check the bottle can pass through.

* If your bottles tend to vary in size, please use multiple bottles for testing.

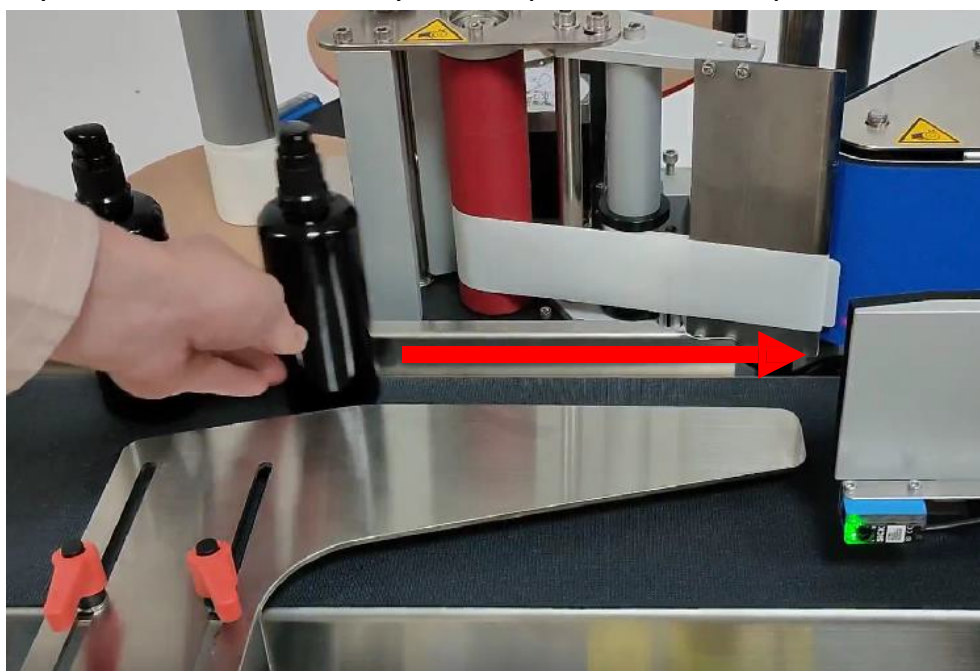



6.4 Wrapping Plate Position

6.4.1 Loosen the handle and place two bottles on each side of the wrapping unit.

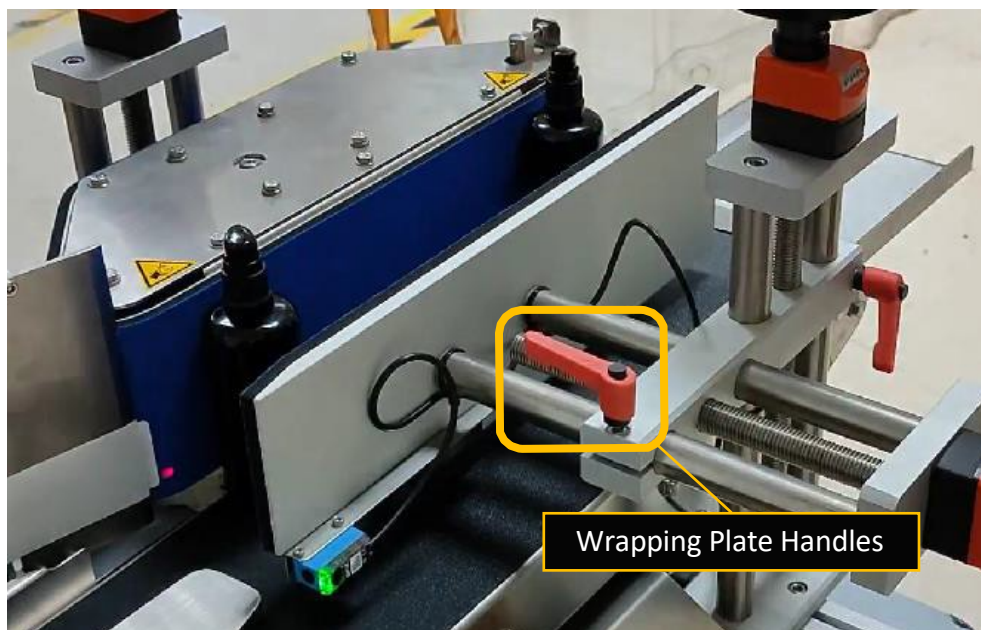

6.4.2 Turn the handwheel until the board clamps the bottles slightly.

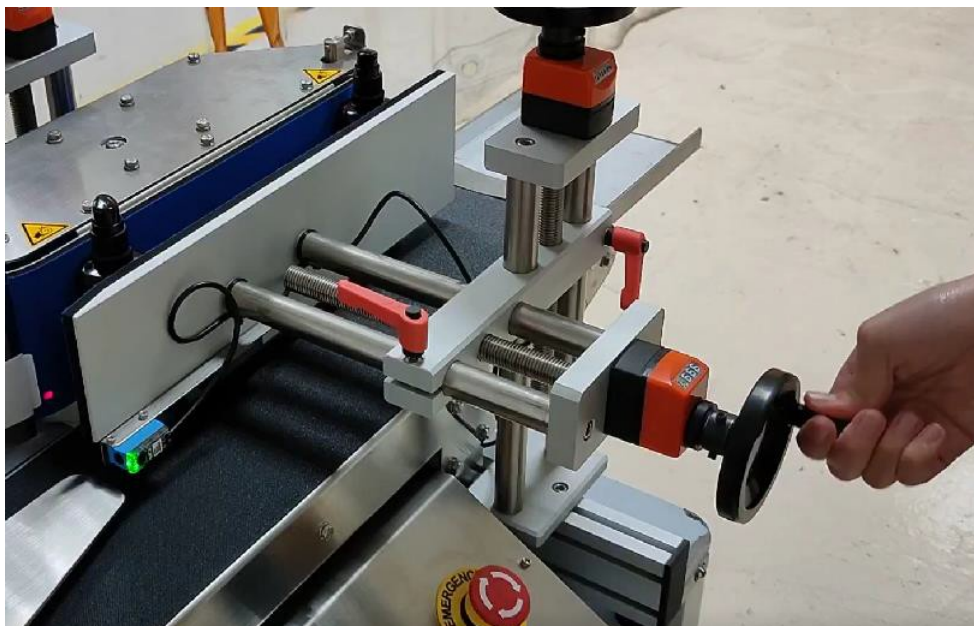



6.4.3 Turn the rotating speed to 50 and check if the bottle can turn smoothly in the wrapping unit.

- * If your bottle's outer diameter varies from bottle to bottle, use multiple bottles to check the parameter. Make sure every bottle can rotate smoothly in the wrapping unit.

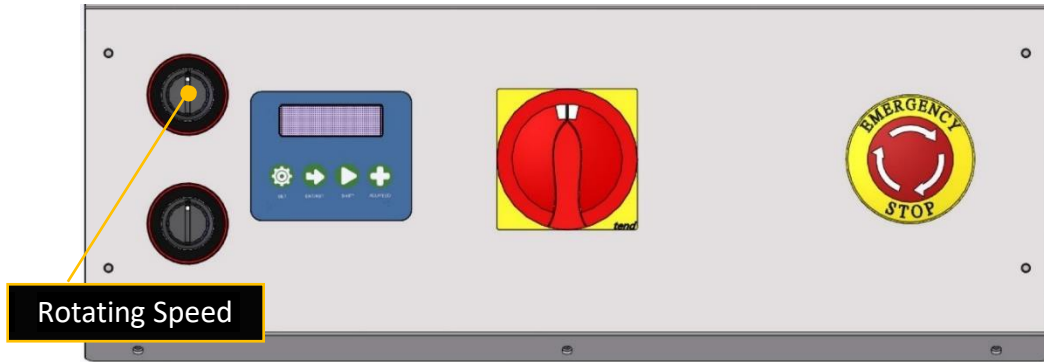

6.4.4 Tighten the handle after adjustment.

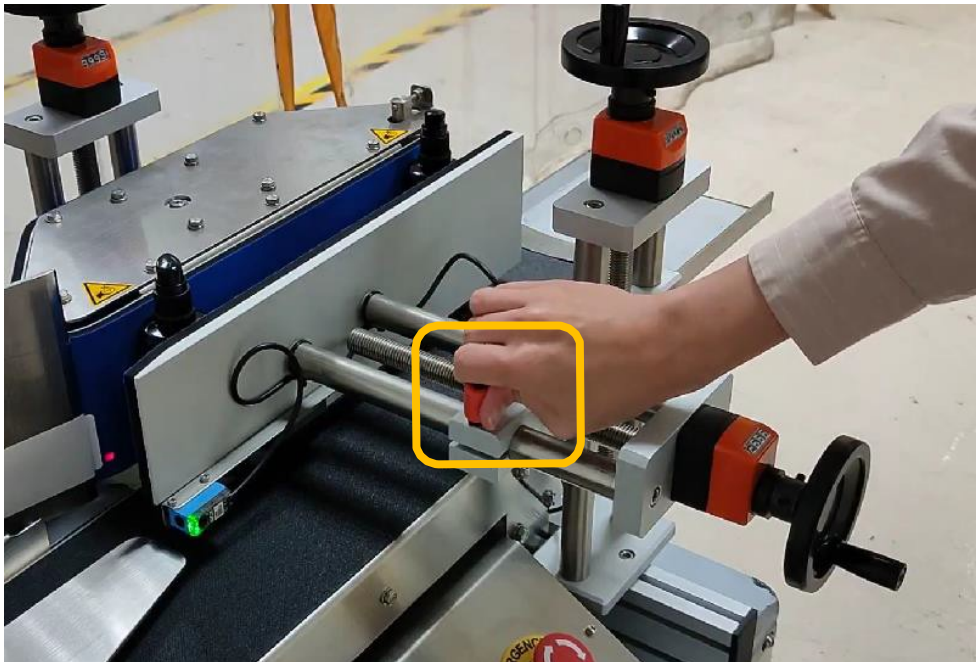



6.4.5 After adjustment, record the parameter on the adjuster for next time.

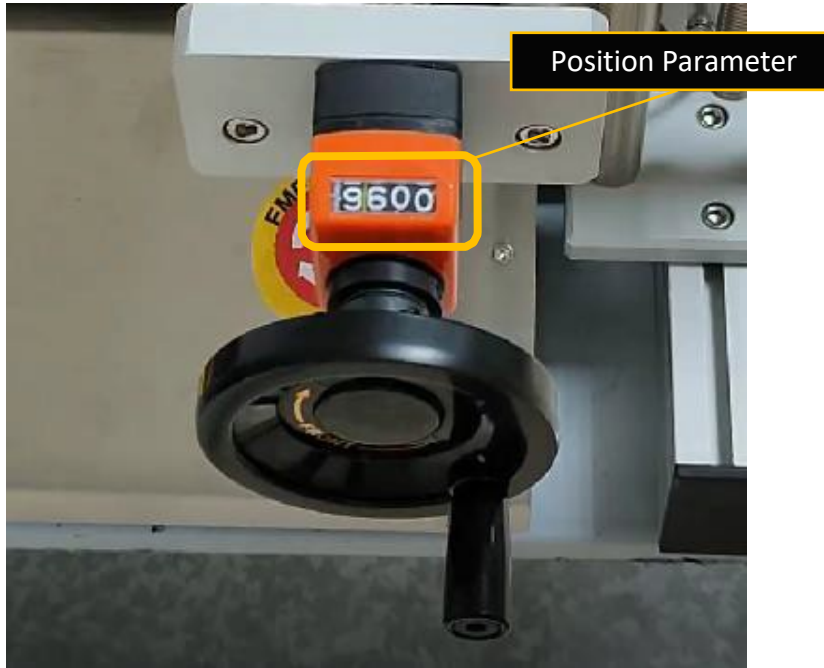

6.4.6 For testing, put three bottles on the conveyor and turn on the conveyor and wrapping unit. Make sure the bottles can pass through smoothly.

* If your bottle's outer diameter varies from bottle to bottle, use multiple bottles to check the parameter. Make sure every bottle can pass through.



6.5 Sensor Adjustment

6.5.1 Bottle Sensor

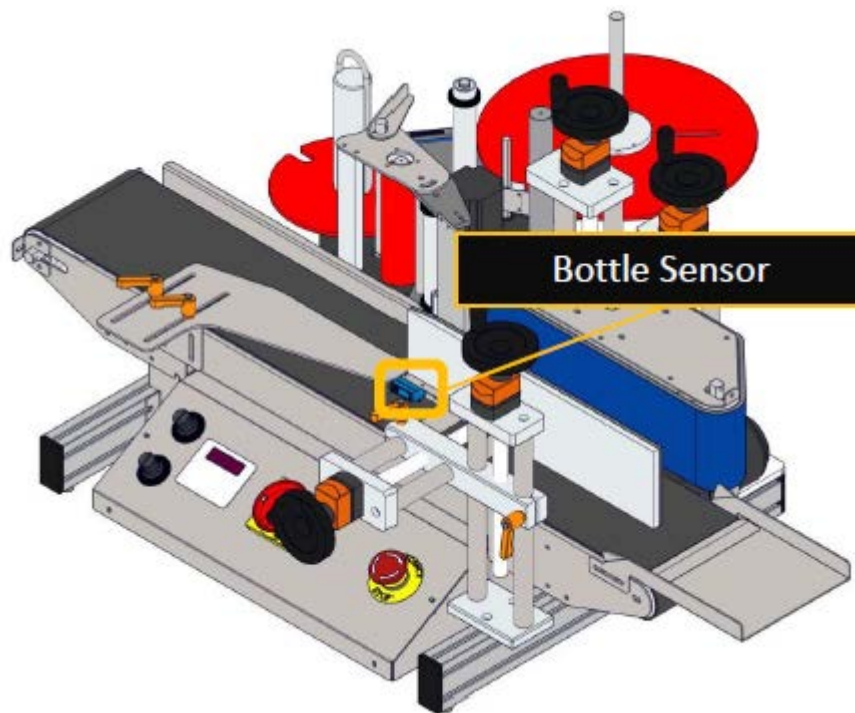

- This sensor detects the bottles. Aim the detection point towards the bottles' bottoms.
- When it detects a bottle passing through, it sends a signal to the labeling application to start labeling
- Check the sensor signal as below

(1) When there is no bottle, the sensor lights up **green**.

(2) When there is a bottle, the sensor lights up **green and yellow**.





- If the sensor is abnormal (the yellow light turns on/off at wrong time), please adjust the sensor setting. Use a screwdriver to adjust its strength. Turn clockwise to increase its strength, and vice versa.

(1) Increase sensor's strength if the yellow light stays on without there being a bottle.

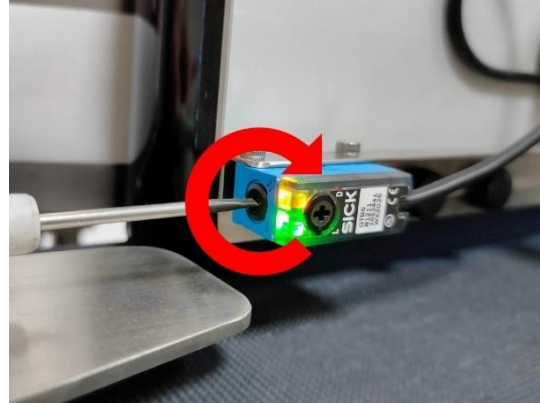

(2) Decrease the sensor's strength if the yellow light does not turn on when there is a bottle.

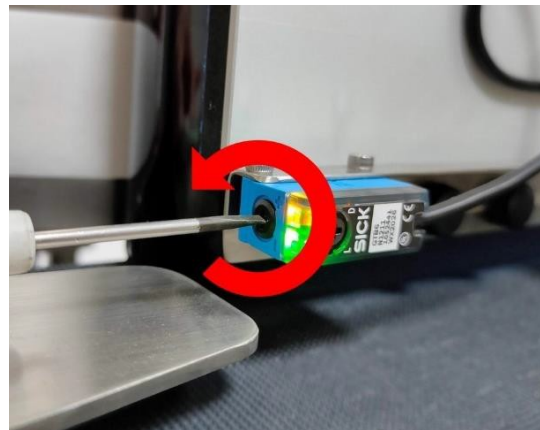

(3) Please check the protruding part points to "L", the light-on mode.





6.5.2 Label sensor and Amplifier

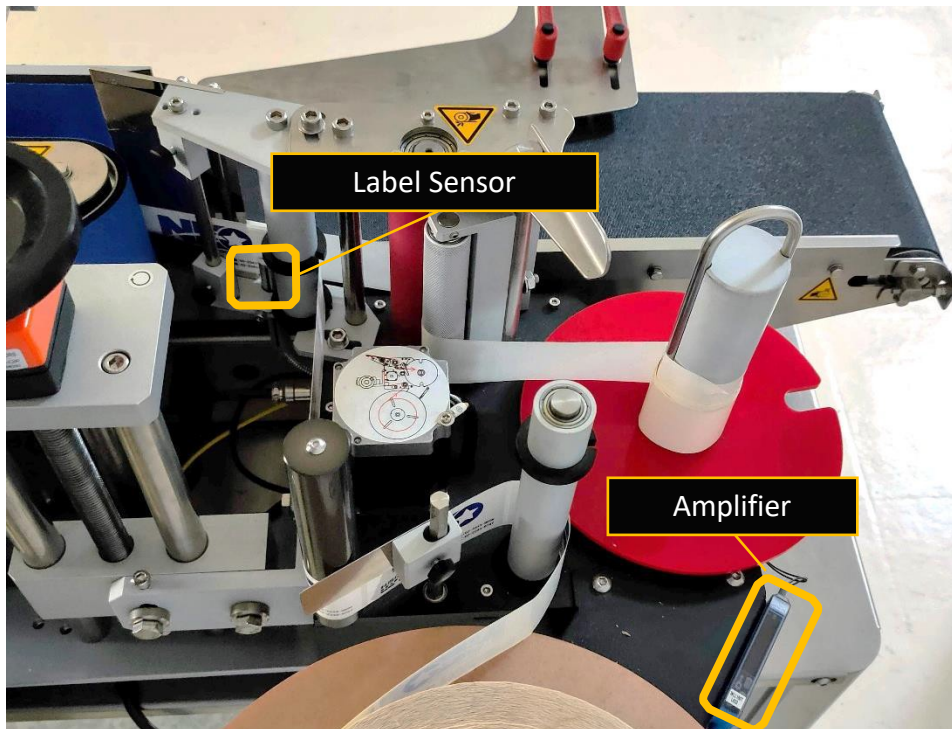

- This sensor detects the presence of the labels.
- The machine differentiates between labels and backing paper by the amplifier setting value.

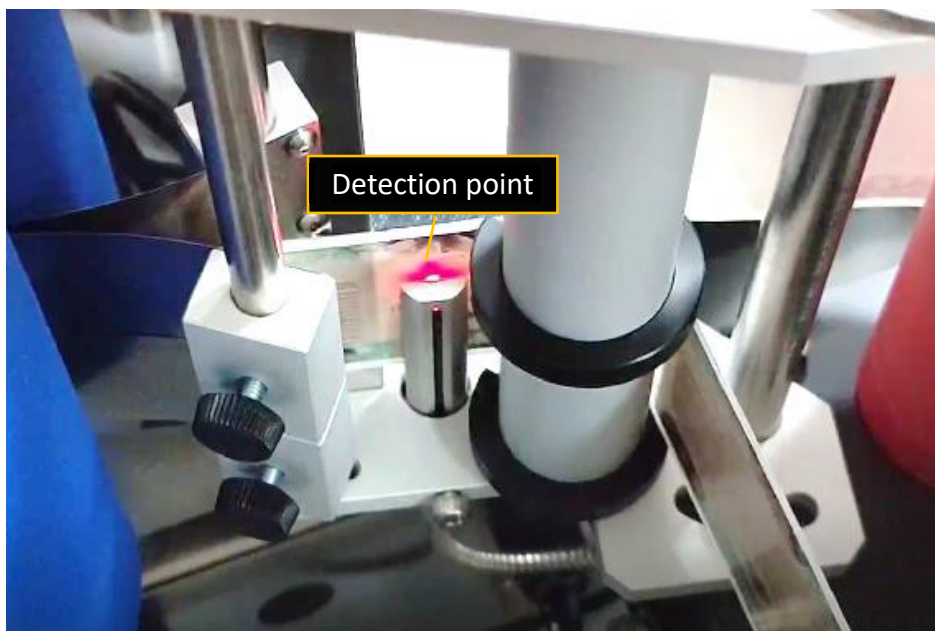

- Make sure the label goes through the label sensor.







6.5.3 Amplifier Setting

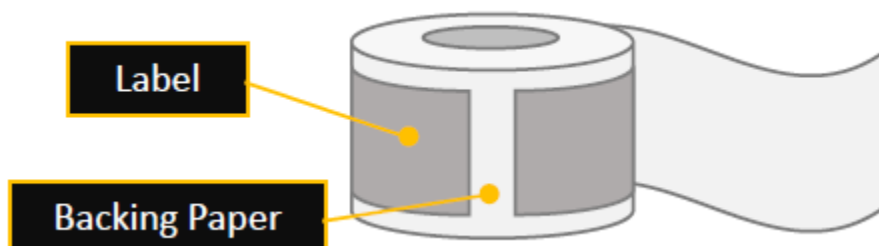

- ① Red number The value of the label which **the sensor detects**
- ② Green number Threshold value which the operator can set
- ③ Mode key Switch between modes
- ④ Adjust key Adjust setting values

- (1) Pull labels through the label sensor and observe the variation of the value.
- (2) Record these two values:
 - (A) The **lowest value** when detecting **backing paper**. (Typically > 9000)
 - (B) The **highest value** when detecting the **label**. (Typically 2000 ~ 4000)



- (3) Calculate the threshold value:
(The lowest backing paper value + The highest label value) ÷ 2 = threshold value
- (4) Press adjust key ( or ), and the green number will start flashing.
- (5) Hold adjust key ( or ) to adjust the value.
- (6) Release the key for 3 seconds to finish setting. When the green numbers stop flashing, the setting is complete.



7 OPERATION

7.1 Start

7.1.1 Check that all the handles, screws, and adjusters are tightened.

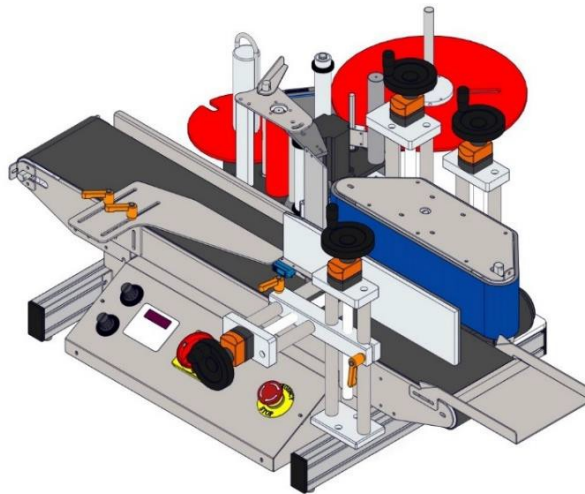

7.1.2 Check whether the emergency stop button is pressed. Twist the button clockwise to release it.

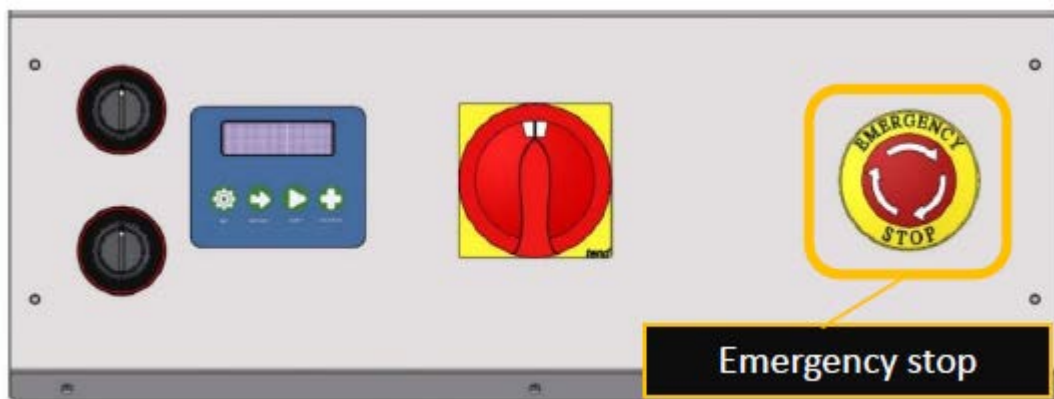

7.1.3 Turn on the power.

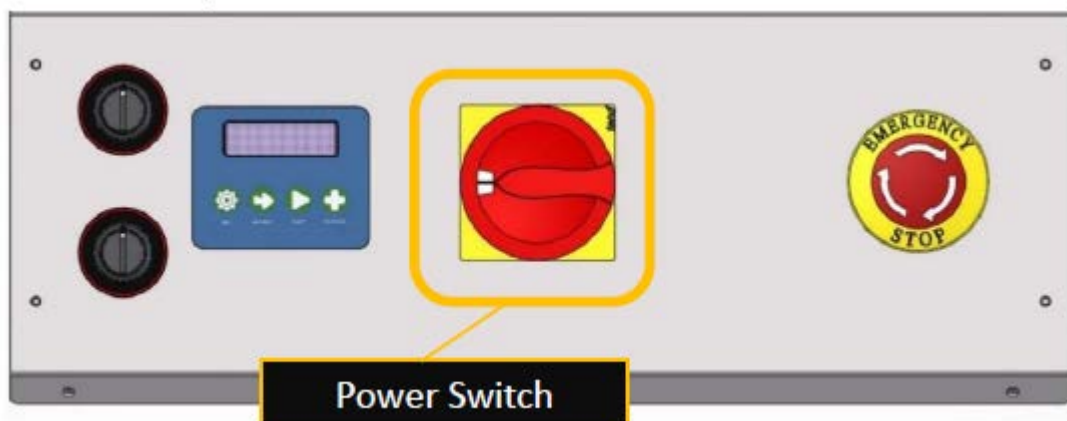



7.2 Speed Adjustment

7.2.1 Turn the conveyor speed to the appropriate value. (recommended parameter: 50)

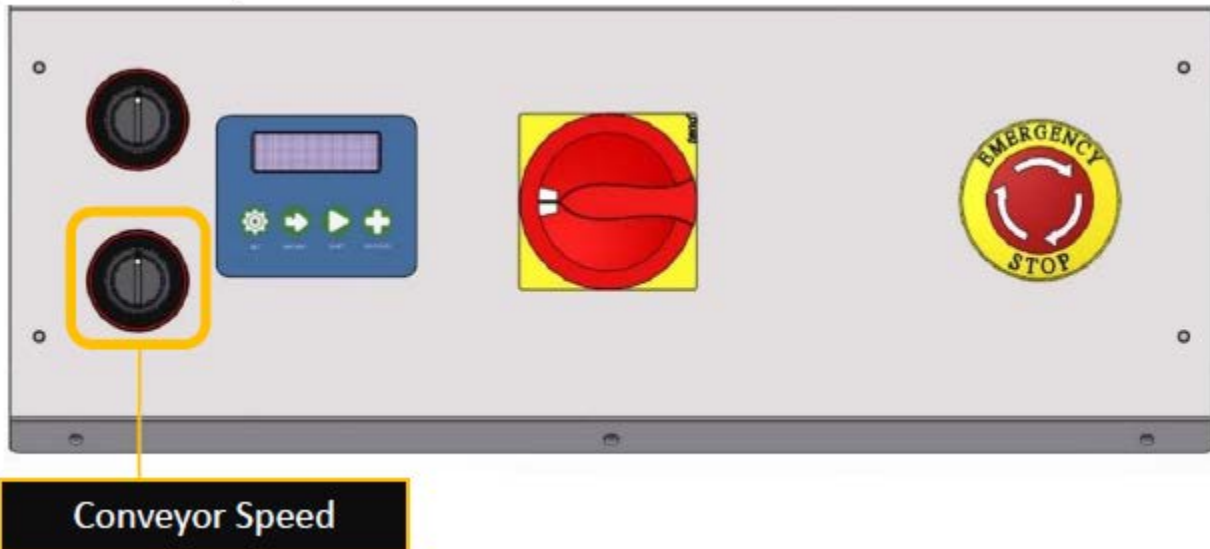

7.2.2 Turn the rotate speed to the appropriate value. (recommended parameter: 50)

- Keep the rotate speed and conveyor speed identical, or they may cause crumpled labeling. Observe the bottle as it goes through the wrapping unit. If conveying and rotating speeds are different, adjust rotate or conveyor knob to achieve the same speed.

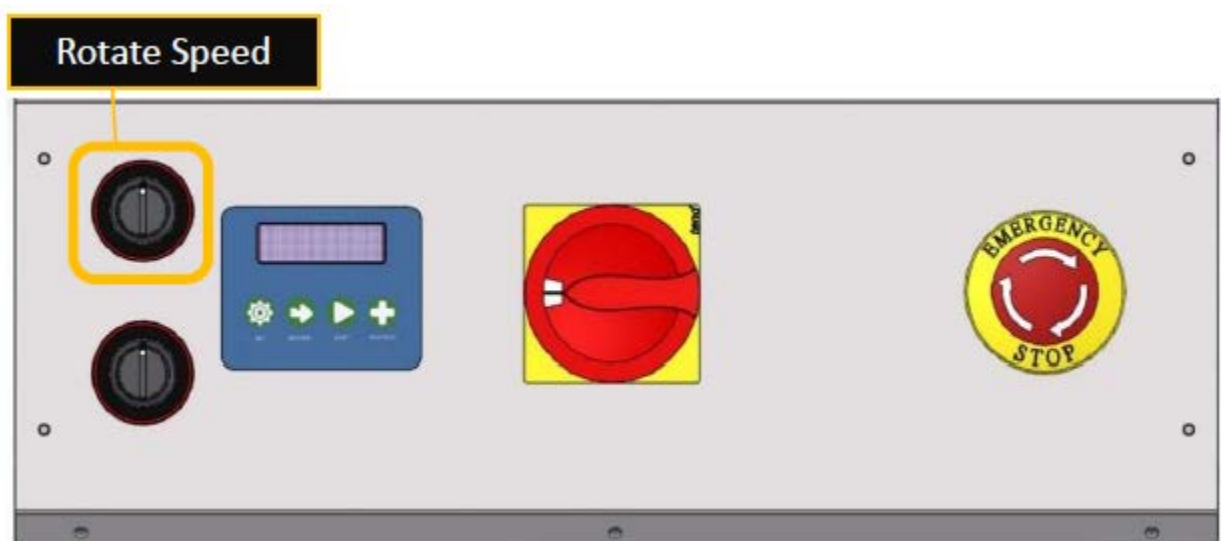



7.2.3 Hold down ADF/FEED **five times continuously** to test label dispensing and to correct the label position.

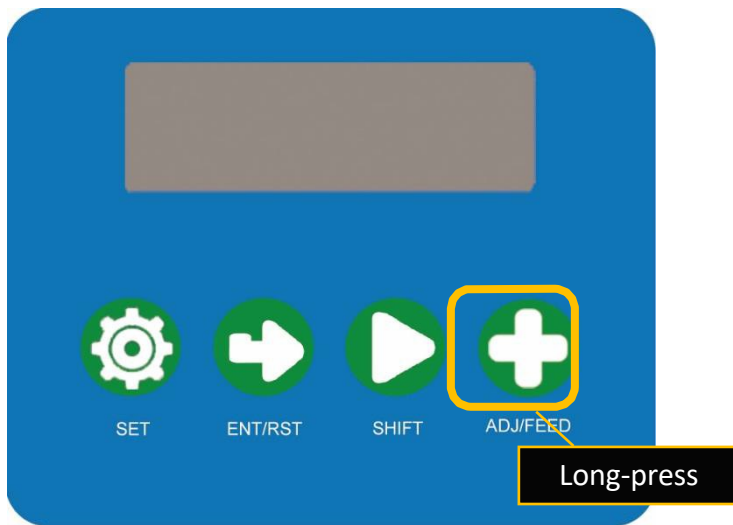

7.2.4 Feed in the bottles, and the machine should start labeling.

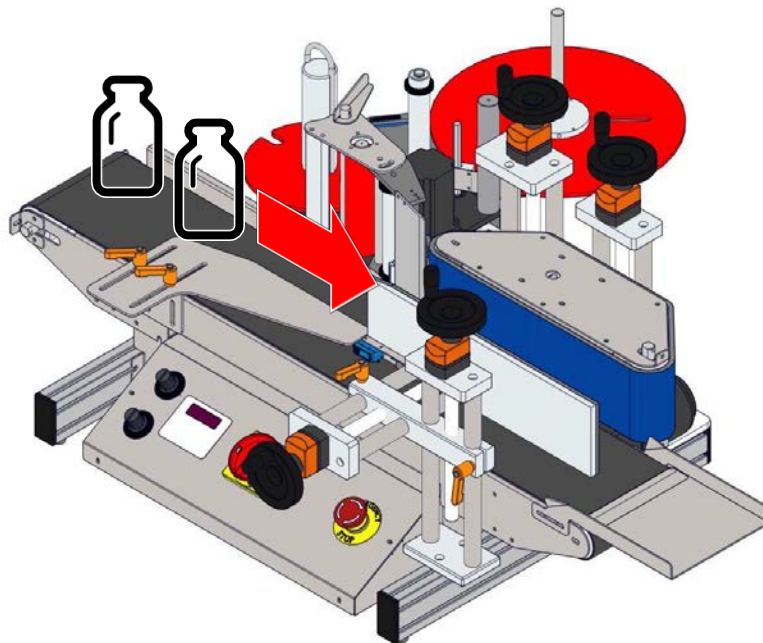



8 MAINTENANCE

8.1 Safety Rules for Electrical Control System

- 8.1.1 Only personnel who are appropriately trained and have adequate knowledge and skill should undertake all electrical/electronic troubleshooting and repair.
- 8.1.2 Do not alter or bypass protective interlocks.
- 8.1.3 Before starting, read and observe all warning labels.
- 8.1.4 When troubleshooting, disconnect the power source and turn off the switch.
- 8.1.5 Take extra precautions in damp areas to protect you from accidental grounding.
- 8.1.6 Before applying power to any equipment, it must be established, without a doubt, that all persons are clear.
- 8.1.7 Do not open the electrical control panel unless it is necessary to check the electrical equipment.
- 8.1.8 Do not alter the electrical circuits unless authorized to do so by the manufacturer.
- 8.1.9 When replacing electrical components, make sure they conform to the manufacturer's specifications, including proper color coding.
- 8.1.10 Do not wear metal frame glasses, metallic necklaces, or chains while working on any electrical equipment. Also, do not wear any rings, watches, or bracelets while operating electrical equipment.

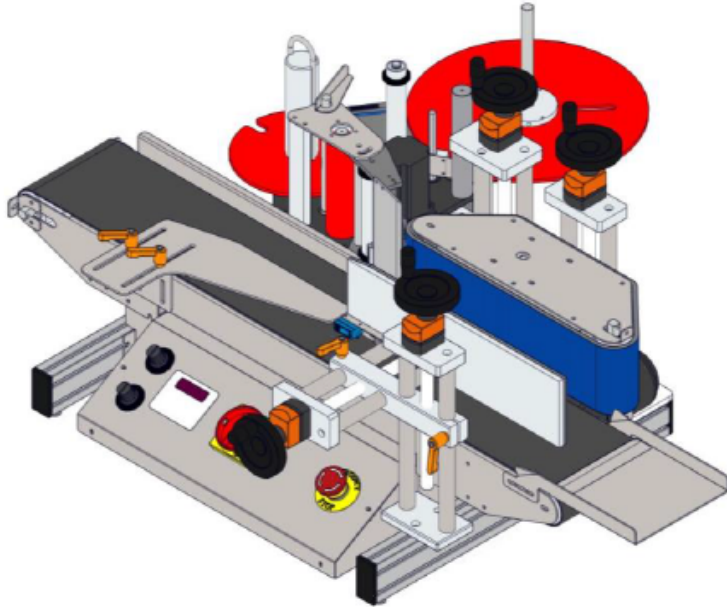

8.2 Regular Maintenance

8.2.1	
Maintenance Area	Machine surface and conveyor
	
Method	Wipe with a dry cloth. Keep it dry and clean.
Frequency	Weekly

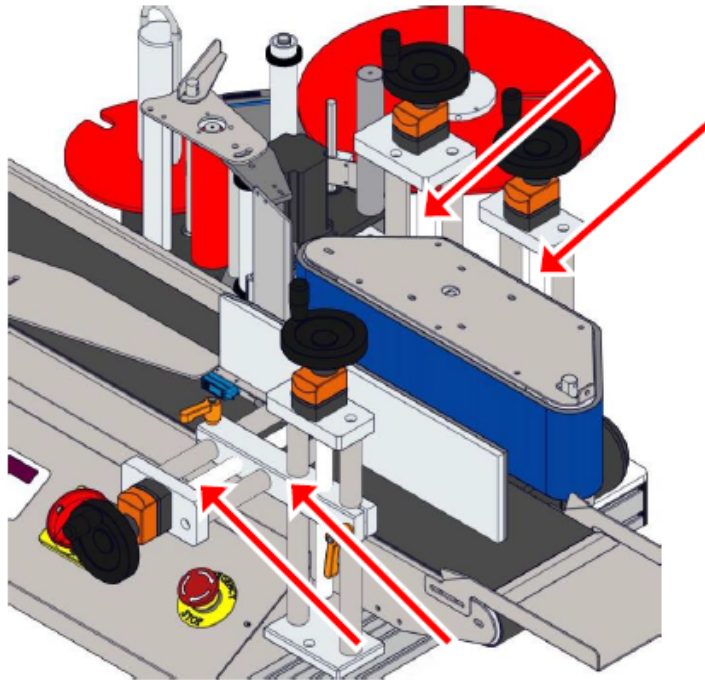
8.2.2	
Maintenance Area	Threaded rods
	
Method	Apply grease to keep them turning smoothly.
Frequency	Every month



8.3 O-ring Replacement

8.3.1 Loose the eight screws circled.



8.3.2 Open the back cover.

8.3.3 Take out and replace the o-ring.

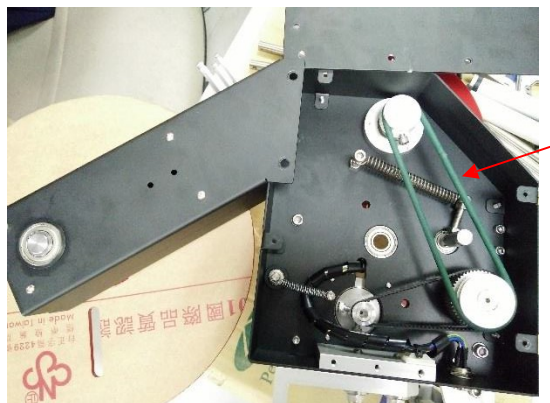

8.3.4 After replacing the o-ring, turn the driving shaft to check that the o-ring will rotate with it.

8.3.5 If the o-ring does rotate, replace cover and screws.





9 TROUBLESHOOTING

Trouble(s)	Possible Causes & Solutions
Out of Power	<ol style="list-style-type: none"> 1. Check if the power switch is ON. (switch to “ — ”) 2. Check if the emergency button is ON. 3. Check if the power supply cable is loose or broken. 4. Check if the safety fuse has blown 5. . (Please follow appendix 2 to set up.)
No Reaction	<ol style="list-style-type: none"> 1. Check that the wire-to-wire connector is in place. 2. Check if every wire is connected firmly. 3. Replace the motor if there is still no change.
Failure To Adjust Speed	<ol style="list-style-type: none"> 1. Match the rotate speed adjuster and conveyor adjuster. If it works, it indicates that the speed adjuster is fine. 2. Check if the variable resistor is loose or broken. 3. Check that every cable is connected firmly.
Dispensing Continuously	<ol style="list-style-type: none"> 1. Check if parameter 2L is too large. 2. Check if the label sensor works. 3. Check if the bottle sensor is under D mode and not L.
Failure in Dispensing	<ol style="list-style-type: none"> 1. Check if the label sensor and amplifier are working. 2. Check if the control panel is working. 3. Check if the start sensor is working.
Crumpled Labeling	<ol style="list-style-type: none"> 1. Parameter 3E may be too high.
Inaccurate labeling	<ol style="list-style-type: none"> 1. The position of the product might be incorrect. 2. The label paper may be curved or loose. 3. The label applicator is not fully horizontal.
Lopsided Labeling	<ol style="list-style-type: none"> 1. Loosen the screw. 2. Adjust label applicator angle.
Control Panel Shows “HELP”	<ol style="list-style-type: none"> 1. Check if the o-ring of the label applicator might be broken. (Please follow section 8.3 to replace the o-ring.) 2. The length of the label is set wrong. (Please follow appendix 13.2 to set up.)

- In case there is any problem or malfunction that you cannot solve, please contact us immediately.



9.1 Out of Power

- 9.1.1 Check if the power supply cable is loose or broken. The socket is behind the machine.

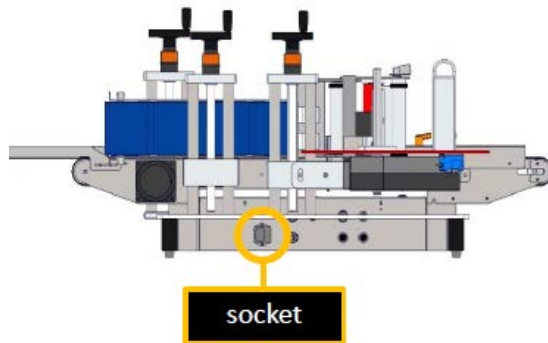

- 9.1.2 Check if the power switch is **ON**. (switch to “ — ”)



- 9.1.3 Release the emergency stop button if it is locked. Twist clockwise to release it.



- 9.1.4 Check if the safety fuse has blown. (Please follow **Appendix 2** to set up.)

- * Safety fuse is beside socket; pull out safety fuse (red mark) to replace.





9.2 No Reaction

Check by following steps:

- 9.2.1 Check that the wire-to-wire connector is connected firmly (Red circle).
- 9.2.2 Check if every wire is connected firmly.
- 9.2.3 Replace the motor if the situation doesn't improve after following the steps above.

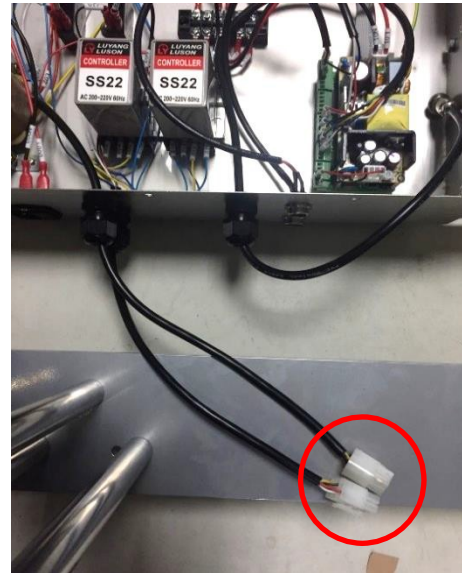

9.3 Failure to adjust speed

Check by following steps:

- 9.3.1 Match the rotate speed adjuster and conveyor adjuster (blue circle) to each other. If it works, this indicates that the speed adjuster is working.
- 9.3.2 Check if the variable resistor (yellow circle) is loose or broken.
- 9.3.3 Check if every wire is connected firmly.
- 9.3.4 Replace the motor if the situation doesn't improve after following the steps above.

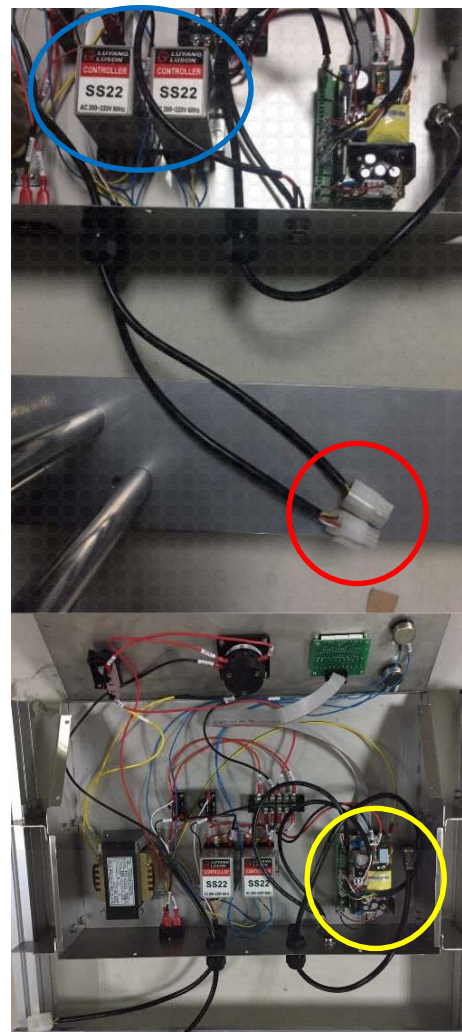



9.4 Dispensing Continuously

- Parameter 2L is too high. (Page 24)
- Check if the label sensor works or not. (Page 43)
- Check if the start sensor is in light-on mode. (Page 42)

9.5 Failure in Dispensing

- Check if the label sensor and amplifier work. (Page 45)
- Check if the control box works. (Page 54)
- Check if the start sensor works. (Page 41)

9.6 Crumple Labeling

- Parameter 3E is too high. (Page 25)

9.7 Inaccurate labeling

- The product is not positioned correctly on the conveyor belt.
- The label paper threaded is curved or loose.
- The label applicator is not fully horizontal.

9.8 Control Panel Shows “HELP”

- The o-ring of the label applicator is broken. (Please follow page 52 to replace the o-ring.)
- The label length parameter is wrong. (Please follow appendix 4 to set up.)



9.9 Lopsided Labeling

9.9.1 Check the bottle. Irregular sizes and shapes may cause lopsided labeling.

9.9.2 Check which side is higher and adjust the angle of the labeling applicator with the following steps:



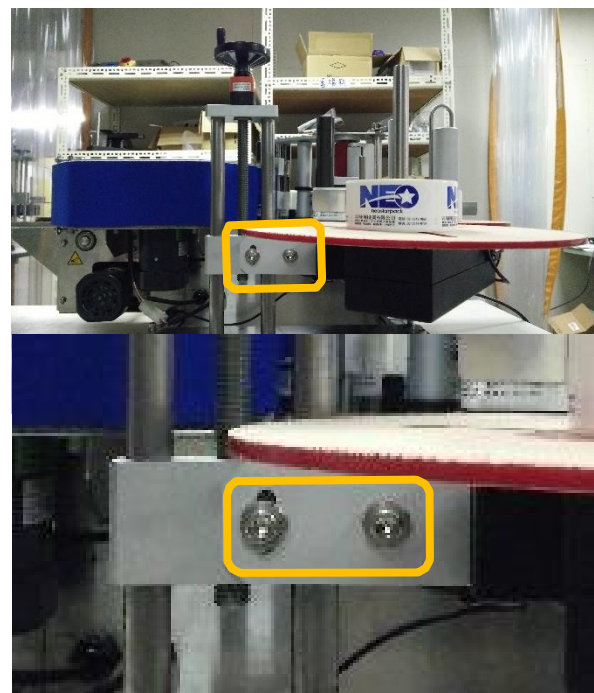

9.9.3 Loosen the two screws behind the labeling applicator.

Notice: hold the label applicator steady while loosening the screws.





9.9.4 Adjust the angle by lifting the lower side slightly.

Problem:	
	
Labeling ends lower.	Labeling ends higher.
The left side (infeed side) of the label applicator is lower than the right	The left side (infeed side) of the label applicator is higher than the right
Solution:	
	
Lift the left side (infeed side) of the label applicator	Lift the right side (outfeed side) of the label applicator

9.9.5 Tighten the screws after adjustment, and test labeling.



10 ELECTRICAL DIAGRAM

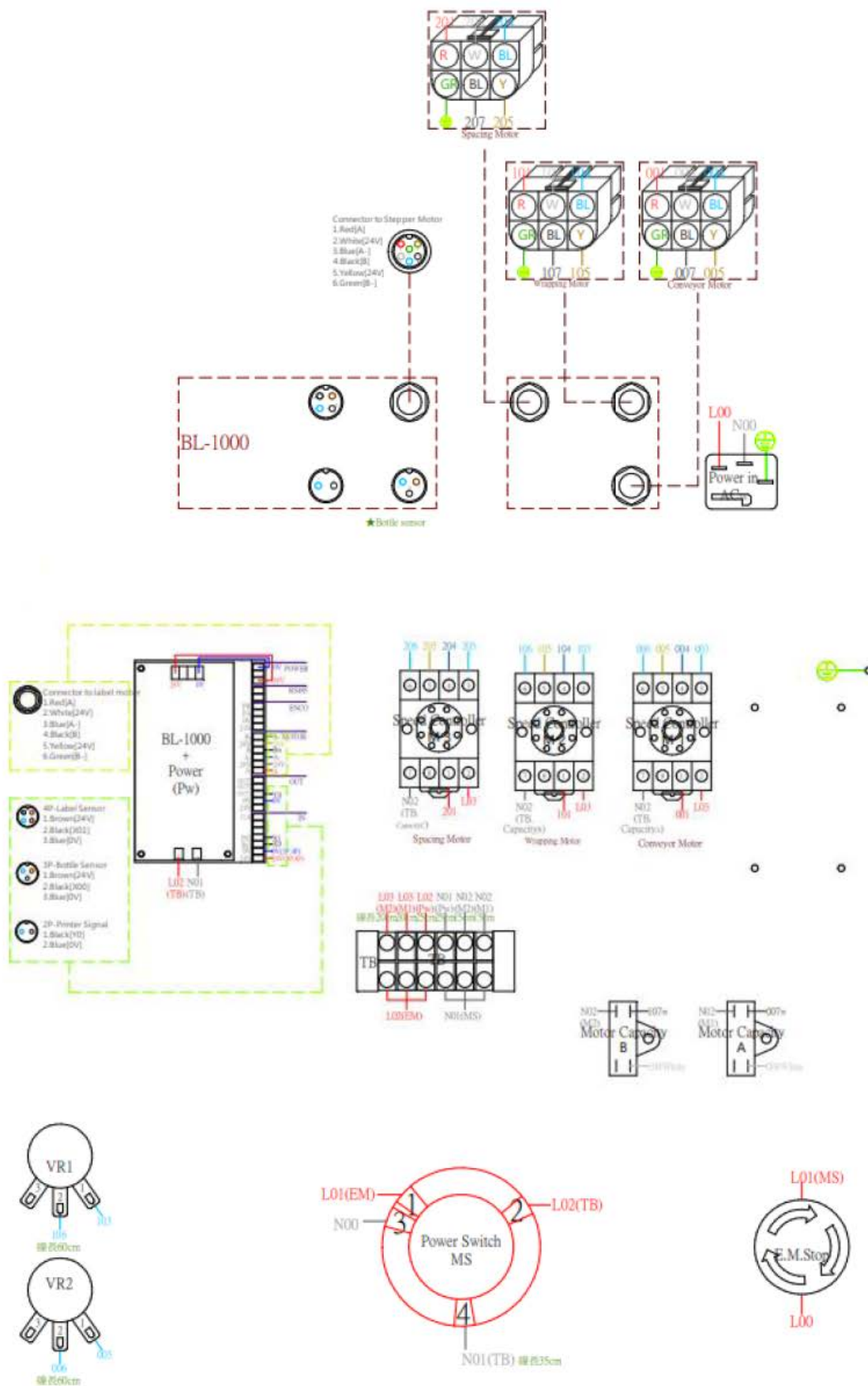



11 REPLACEMENT PARTS

No.	Description	Quantity
Spare Parts		
1	O-RING (410mm)	1
2	O-RING (270mm)	1
Accessories		
3	Cable	1
4	Collecting tray set	1



12 PART LIST

No.	Name	Part Number	Brand
1	O-RING 270mm	280mm_NLA110-02	Neostarpack
2	Label Head Spring (A)	SP20150001	Neostarpack
3	Timing Belt	HTD279-3M	Neostarpack
4	Label Head Spring (B)	SP20150002	Neostarpack
5	O-RING 410mm	410mm_NLA110-02	Neostarpack
6	Label Sensor - AMPLIFIER	WLL180T-L632	SICK
7	Label Guide Ring	NLA100-A01-C20	Neostarpack
8	Backing Paper Spool Disc	NLA110-A02-P00	Neostarpack
9	Backing Paper Holder Pin	NLA110-A02SAM-C11	Neostarpack
10	Feed Spool Disc	NLA110-A02-P01	Neostarpack
11	Drag Spring Plate	NLA110-A02-L10+NLA110-A02-W08	Neostarpack
12	Label sensor set (including U shape base and two fiber cables)	FM-NLA1000	Neostarpack
13	Label Tension Plate	NLA110-A02-W13+NLA110-A02-L12	Neostarpack
14	Clear Label Sensor (Optional)	UFN3-70N415	SICK
15	Peeling Plate	NLA110-A02-L06	Neostarpack
16	Knob for Rotate Speed	JK-906B	Neostarpack
17	Knob for Conveyor Speed	JK-906B	Neostarpack
18	Driver board	BL-1000	Neostarpack
19	Power switch	ZH-HD-1-80-BY	ChyienHwang
20	Emergency stop button	E2R1R1B	EMA
21	Handwheel and position indicator	7302232-80X10X25 NT3 SK414-2.0E-10-OP NT279 8	Neostarpack



22	Conveyor Belt	NLR1000-B00-T00-191227	Neostarpack
23	Wrapping Belt	NLR1000-D00-T00	Neostarpack
24	Bottle Sensor	GTB6-N1211	SICK
25	Sponge Plate	NLR1000-E00-T00	Neostarpack
26	Timing Belt for conveyor	HTD390-5M-9	Neostarpack
27	Conveyor Motor Gearbox	4GN25K	Neostarpack
28	Conveyor Motor	4IK25RGN-C	Neostarpack
29	Wrapping Station Motor	4IK25RGN-C	Neostarpack
30	Wrapping Station Gearbox	4GN12.5K	Neostarpack
31	Timing Belt for wrapping s	HTD375-5M-9	Neostarpack



12.1 Labeling Applicator

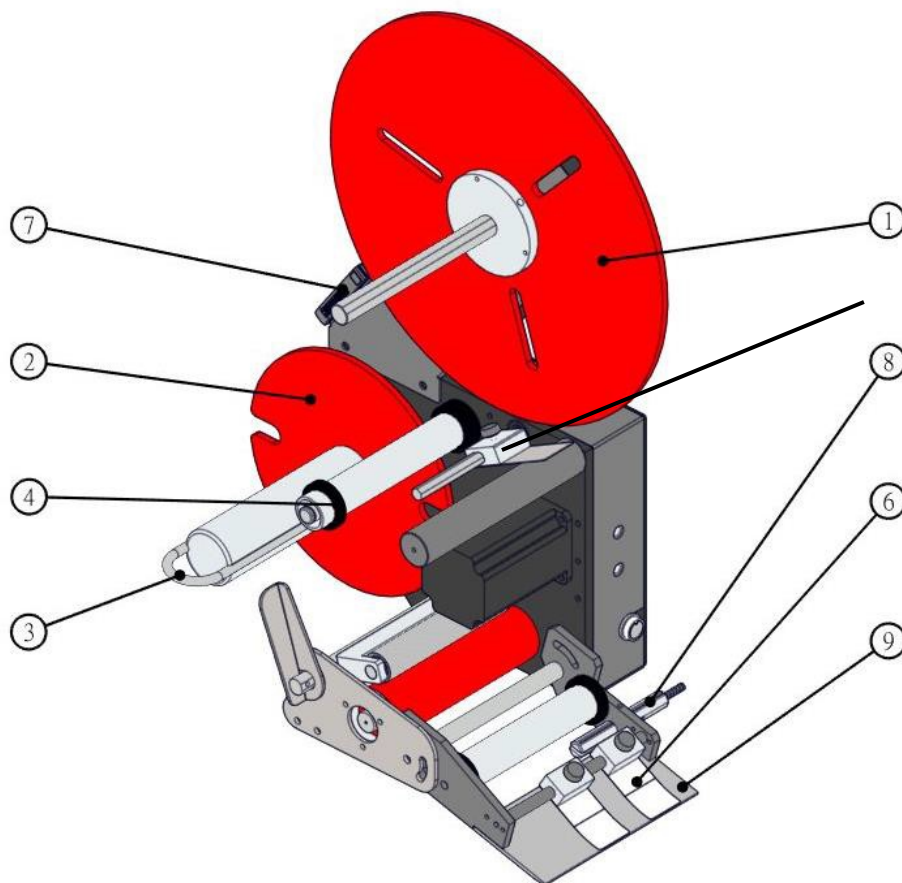

①	Feed Spool Disc	NLA110-A02-P01
②	Backing Paper Spool Disc	NLA110-A02-P00
③	Backing Paper Holder Pin	NLA110-A02SAM-C11
④	Label Guide Ring	NLA100-A01-C20
⑤	Drag Spring Plate	NLA110-A02-L10+NLA110-A02-W08
⑥	Label Tension Plate	NLA110-A02-W13+NLA110-A02-L12
⑦	Label Sensor - AMPLIFIER	WLL180T-L632
⑧	Label Sensor Set	FM-NLA1000

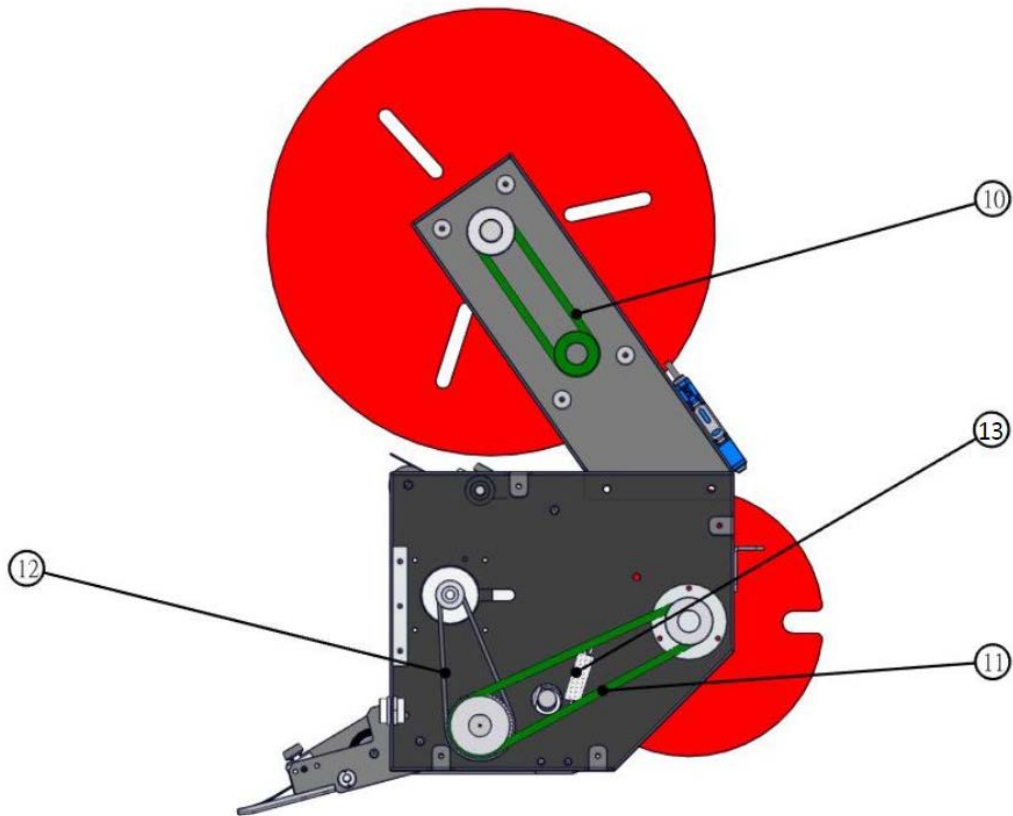

①①	O-RING 270mm	280mm_NLA110-02
①②	O-RING 410mm	410mm_NLA110-02
①③	Timing Belt	HTD279-3M
①④	Label Head Spring (B)	SP20150002



12.2 Control Panel and Conveyor

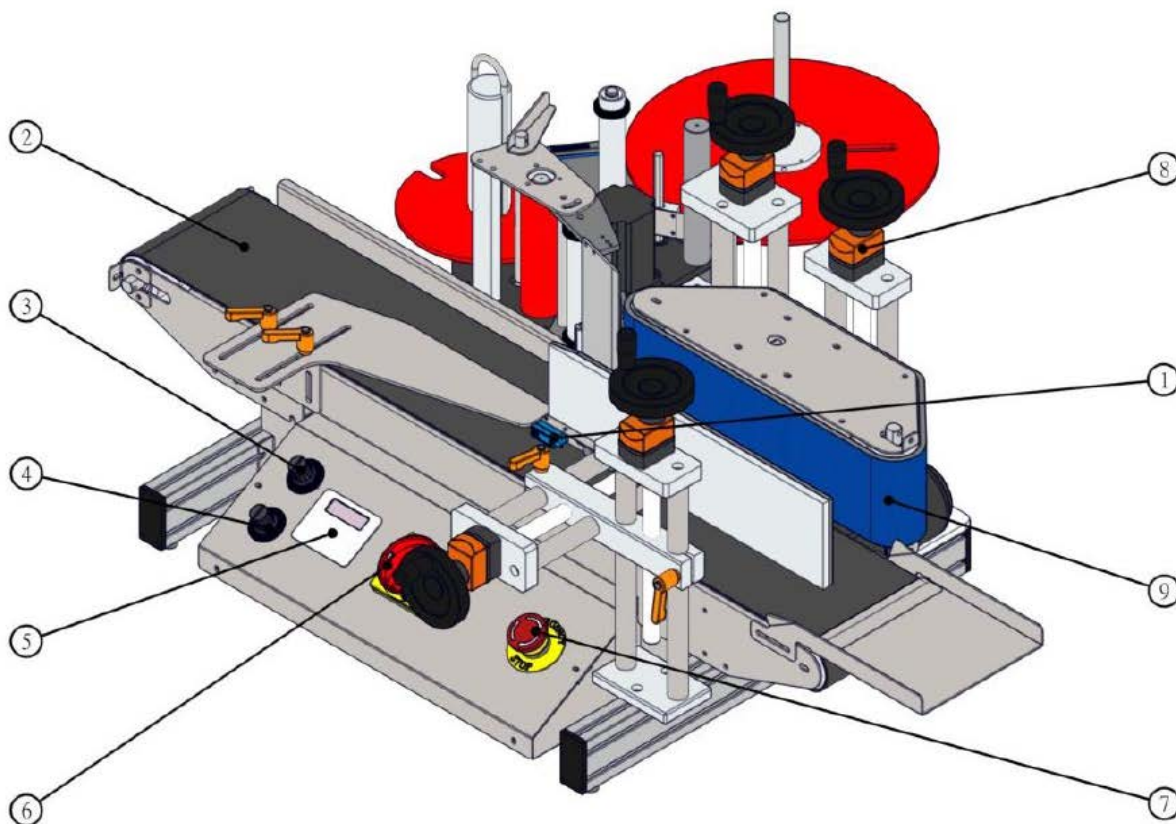

①	Bottle Sensor	GTB6-N1211
②	Conveyor Belt	NLR1000-B00-T00-191227
③	Knob For Rotate Speed	JK-906B
④	Knob For Conveyor Speed	JK-906B
⑤	Driver Board	BL-1000
⑥	Power Switch	ZH-HD-1-80-BY
⑦	Emergency Stop Button	E2R1R1B
⑧	Handwheel And Position Indicator	7302232-80X10X25 NT3 SK414-2.0E-10-OP NT279 8
⑨	Wrapping Belt	NLR1000-D00-T00



12.3 Wrapping Unit

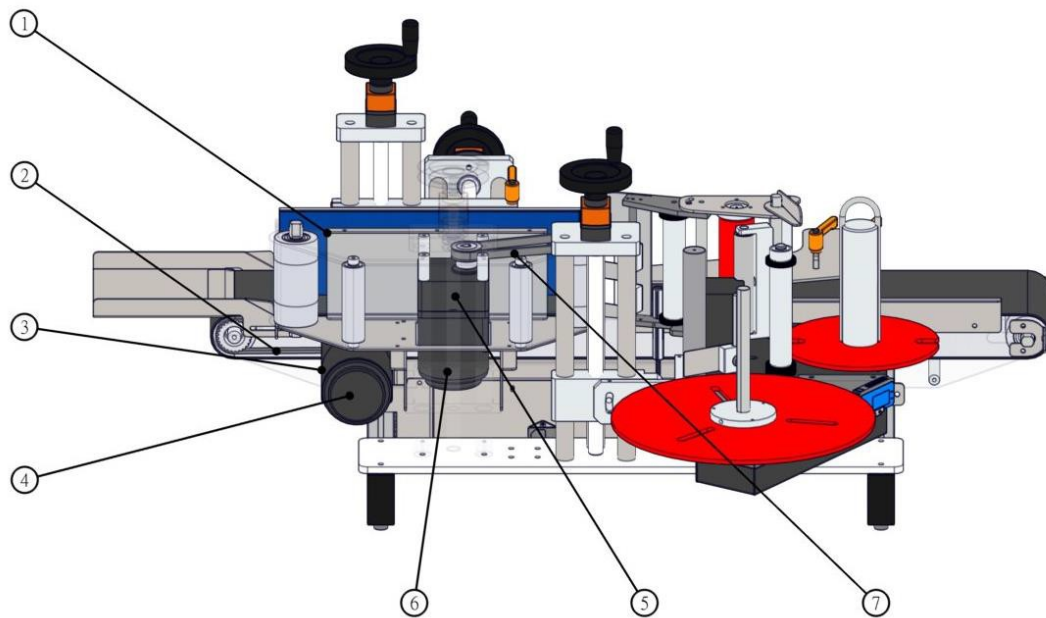

①	Sponge Plate	NLR1000-E00-T00
②	Timing Belt For Conveyor	HTD390-5M-9
③	Conveyor Motor Gearbox	4GN25K
④	Conveyor Motor	4IK25RGN-C
⑤	Wrapping Station Gearbox	4GN12.5K
⑥	Wrapping Station Motor	4IK25RGN-C
⑦	Timing Belt For Wrapping Set	HTD375-5M-9



13 APPENDIX

13.1 Fuse Replacement

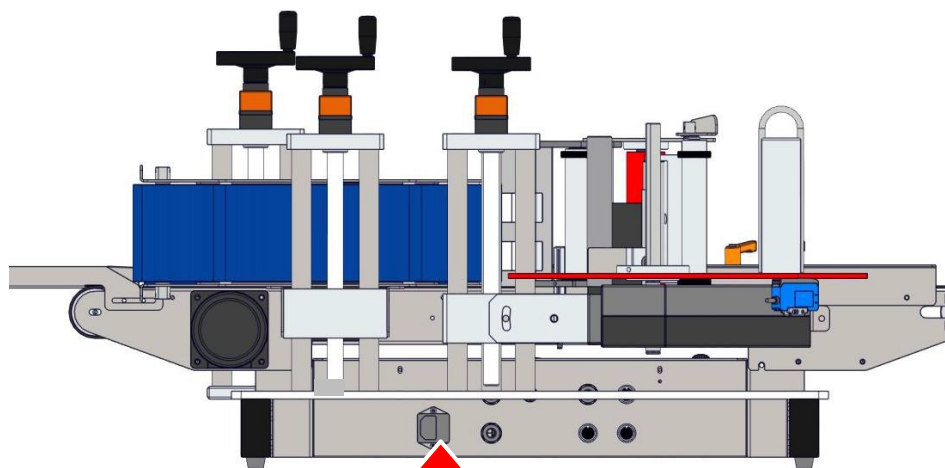

Socket is behind the machine.



13.1.1 The fuse is next to the socket. Pull it out to check and replace the fuse.



13.1.2 The fuse (red arrow) is spare.





13.2 Label Length Checking Setting

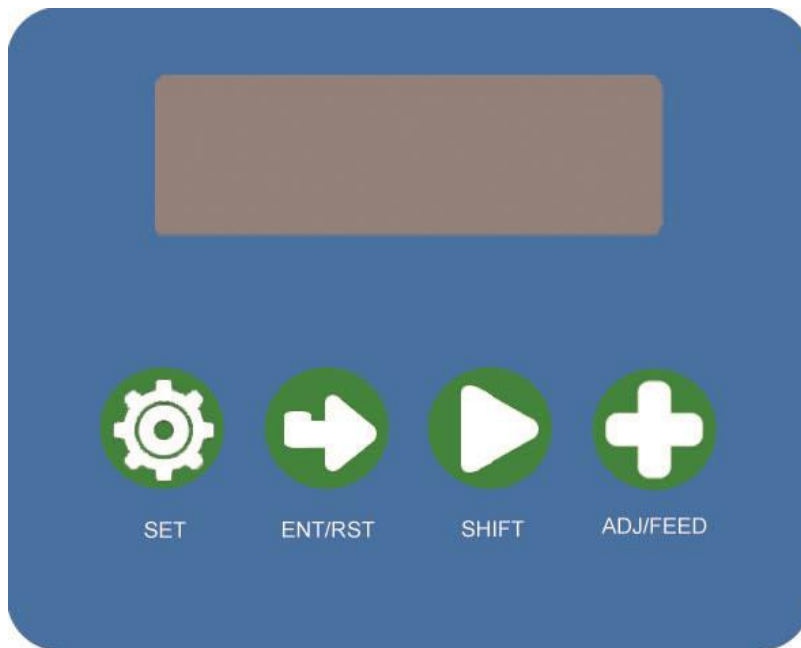

When the label length changes significantly, the label sensor cannot recognize the new length. Thus, the control panel will show **“HELP.”**

Hold down ADJ/FEED button for about 2 seconds to dispense one label and reset the label length setting.



13.3 Clear Label Sensor Setting (Optional)



13.3.1 Make sure the label goes through the sensor.



13.3.2 Check the sensor operation as follows:

When the **backing paper** passes through the detection point, the sensor lights up **yellow**.



When the **label** passes through the detection point, the sensor does not light up.





13.3.3 Auto teaching

(1) Press + and – for 1 second, and the sensor will start flashing red light.

- Press + and – for 3 seconds, and the sensor will be locked or unlocked. For 6 seconds, it will switch to L or D mode.



(2) Move the label and make three labels pass through the sensor.

Please hold each side of the label (see picture) to make sure the label is taut.

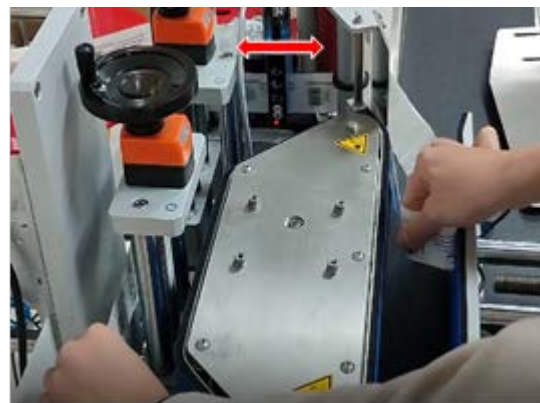

(3) Press – for 1 second to finish auto teaching.

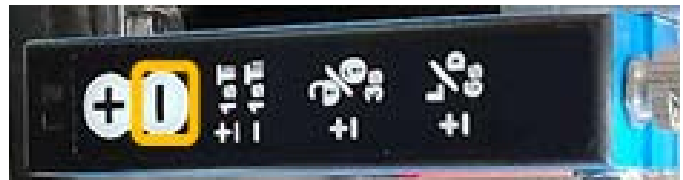

(4) Move the label to check sensor operation.





When the **backing paper** passes through the detection point, the sensor lights up yellow; when the **label** passes through the detection point, the sensor does **not** light up.



(5) In case the yellow light does not work, please repeat auto teaching, or see the next section for manual teaching instructions.



13.3.4 Manual teaching

<p>(1) Hold + for 3 seconds to reset the sensor.</p>	
<p>(2) Move the label so that a label, rather than the backing paper, is covering the sensor. The sensor should light up yellow now.</p>	
<p>(3) Press – slowly to adjust the threshold value. Press it <u>until the yellow light turns off when detects on the label.</u></p>	
<p>(4) Move the label to check sensor operation. When the backing paper passes through the detection point, the sensor lights up yellow; when the label passes through the detection point, the sensor does not light up.</p>	



13.4 Printer Setting (Optional)

13.4.1 Components

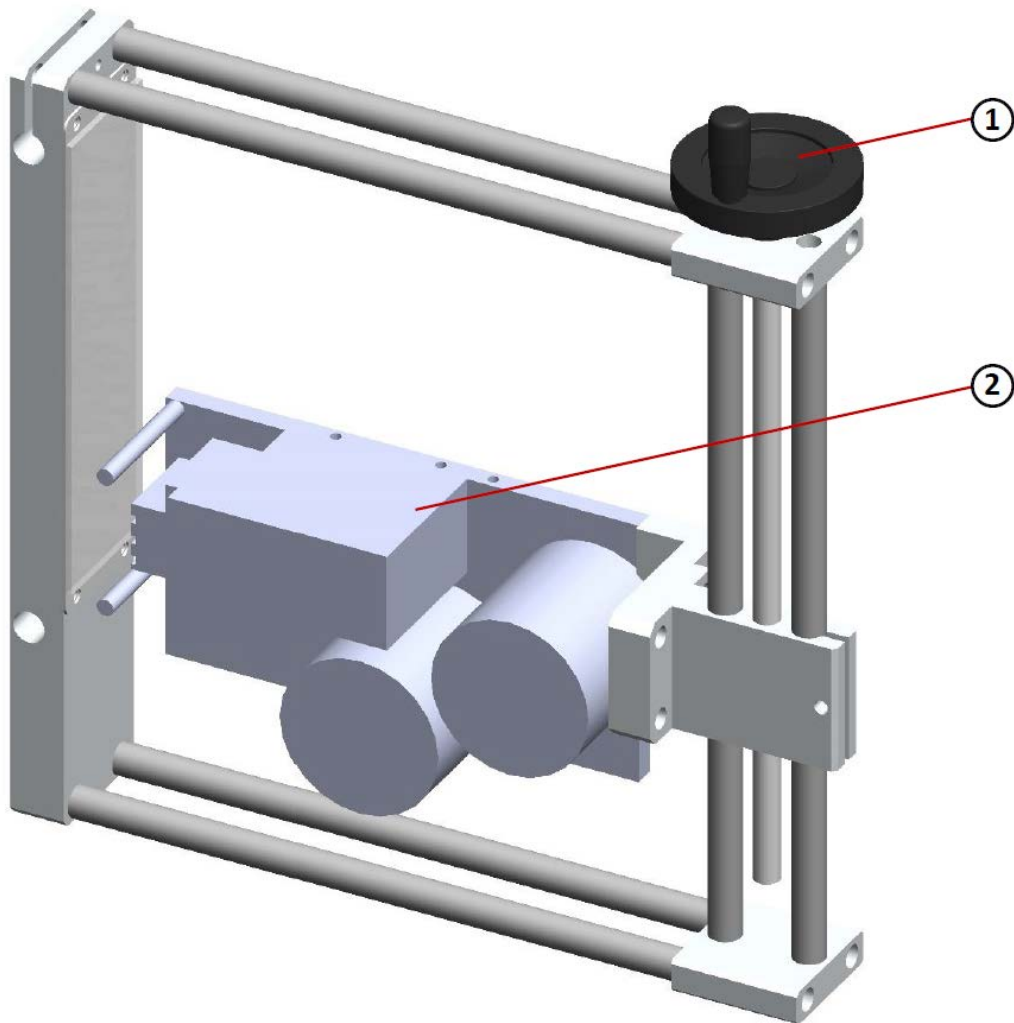

① Height Adjuster

② Printer

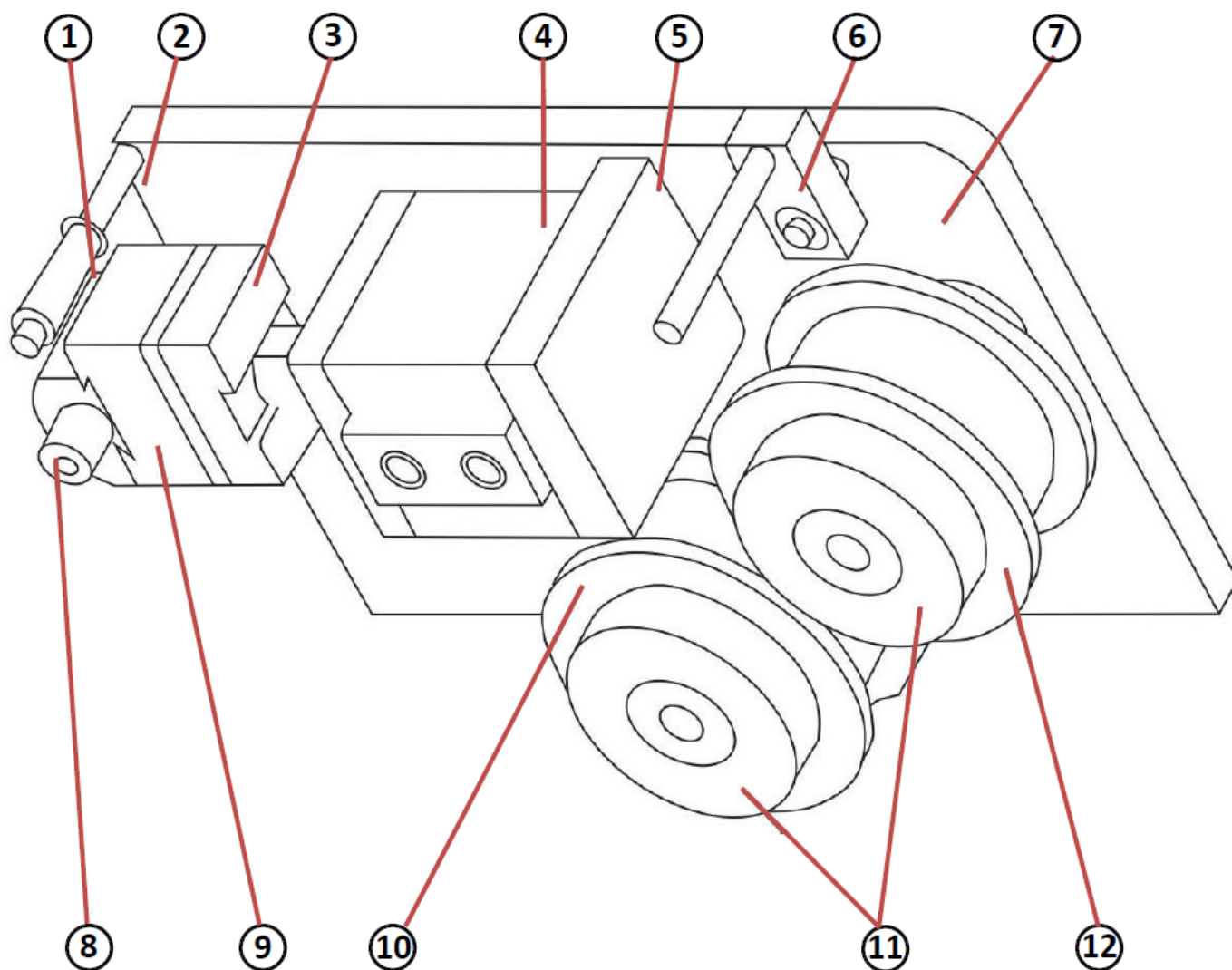

- | | |
|-----------------------------|-------------------------|
| ① PE Pulley | ⑦ Motherboard |
| ② Pulley Shaft | ⑧ Type Holder |
| ③ Cylinder Linking Stan | ⑨ Heating House |
| ④ Mono-cylinder | ⑩ Big Plastic Plate |
| ⑤ Left Cylinder Fixed Stand | ⑪ Left Black Fixed Knob |
| ⑥ Left Buffering Rod | ⑫ Small Plastic Plate |

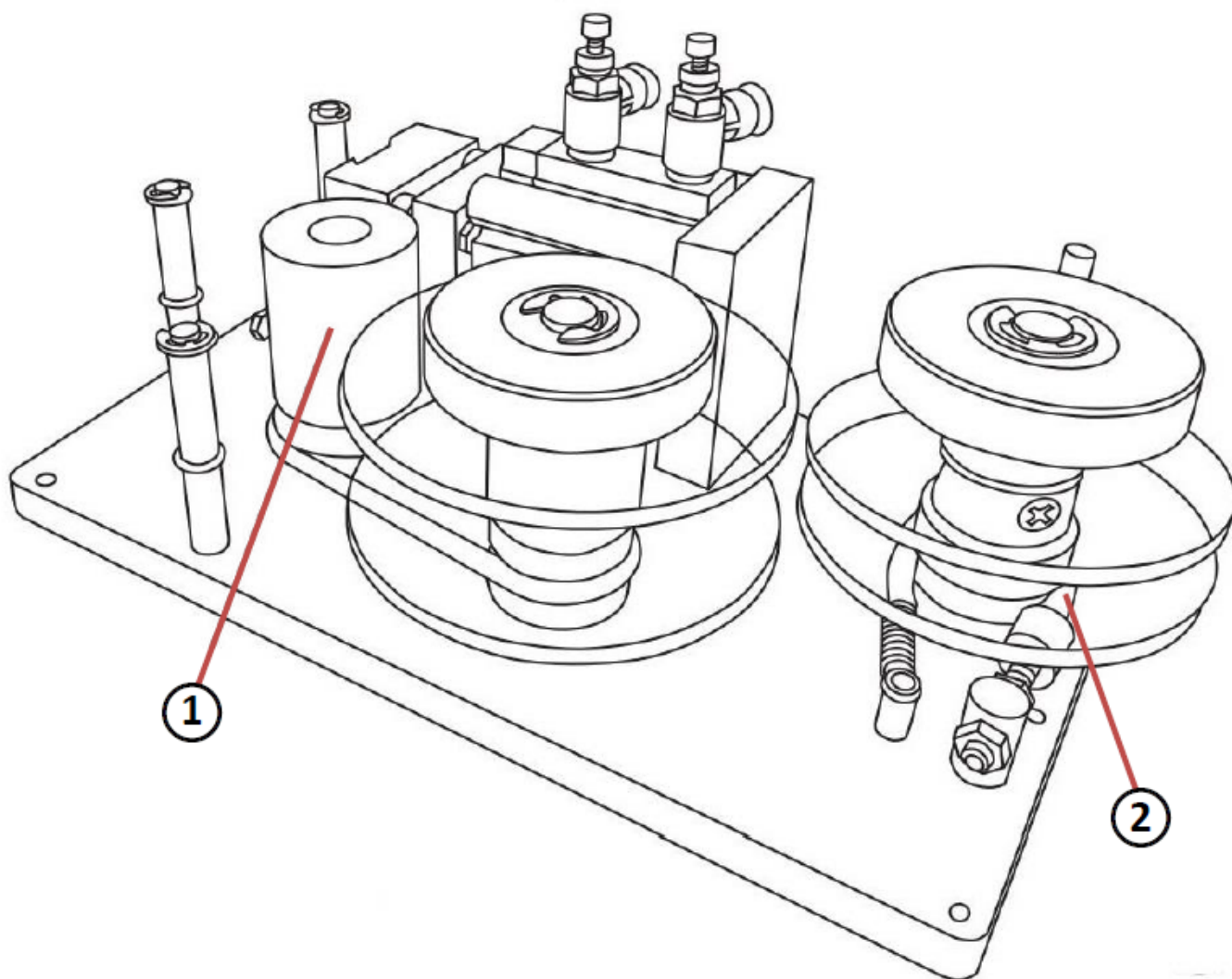

① Code Foil Driving Wheel

② Fixed Belt Set

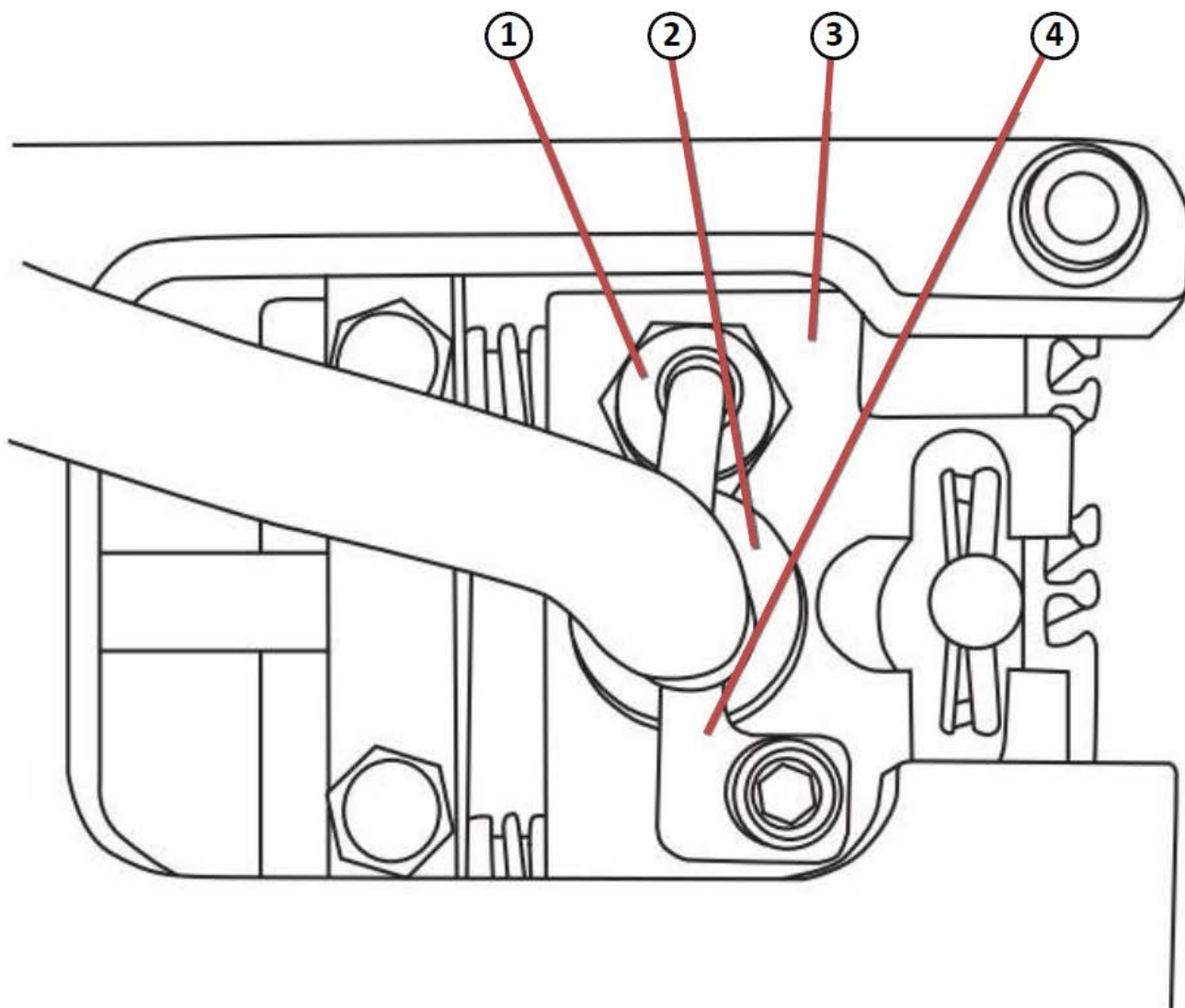

① Thermocouple

③ Type Holder Stopped Board

② Heater

④ Heater Fixed Board



13.4.2 Adjustment

- (1) Before adjusting the printing position, please finish setting 2L and fix the position of the label sensors.
- (2) Loosen the hand lever.

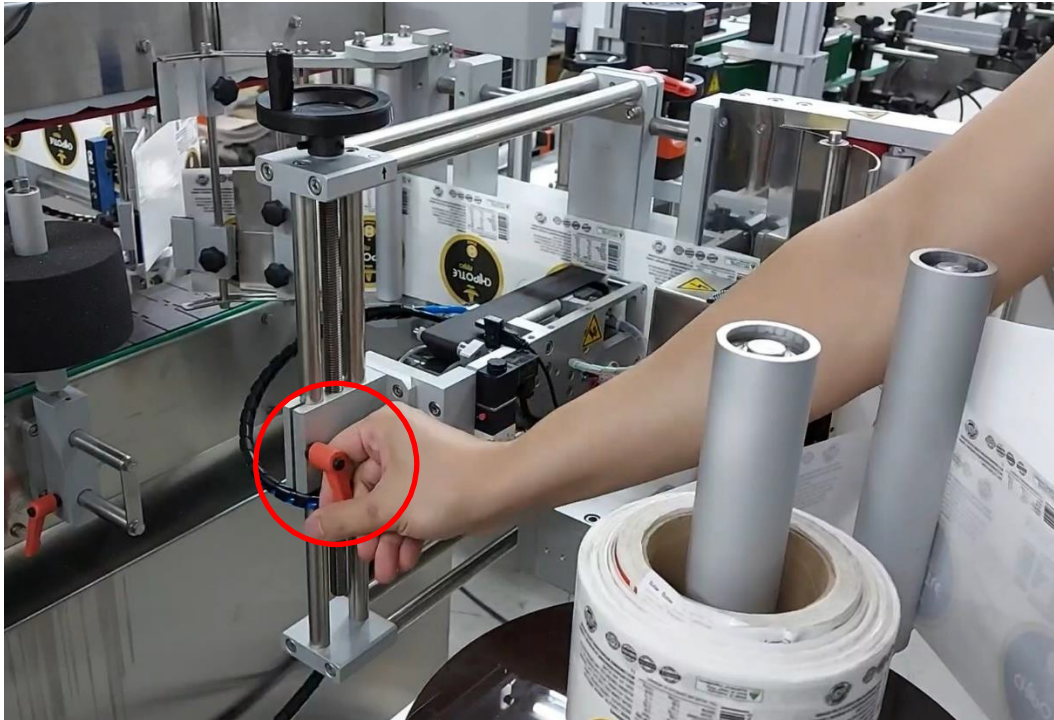

- (3) Turn the hand wheel to adjust printing height.





- (4) Tighten the hand lever.

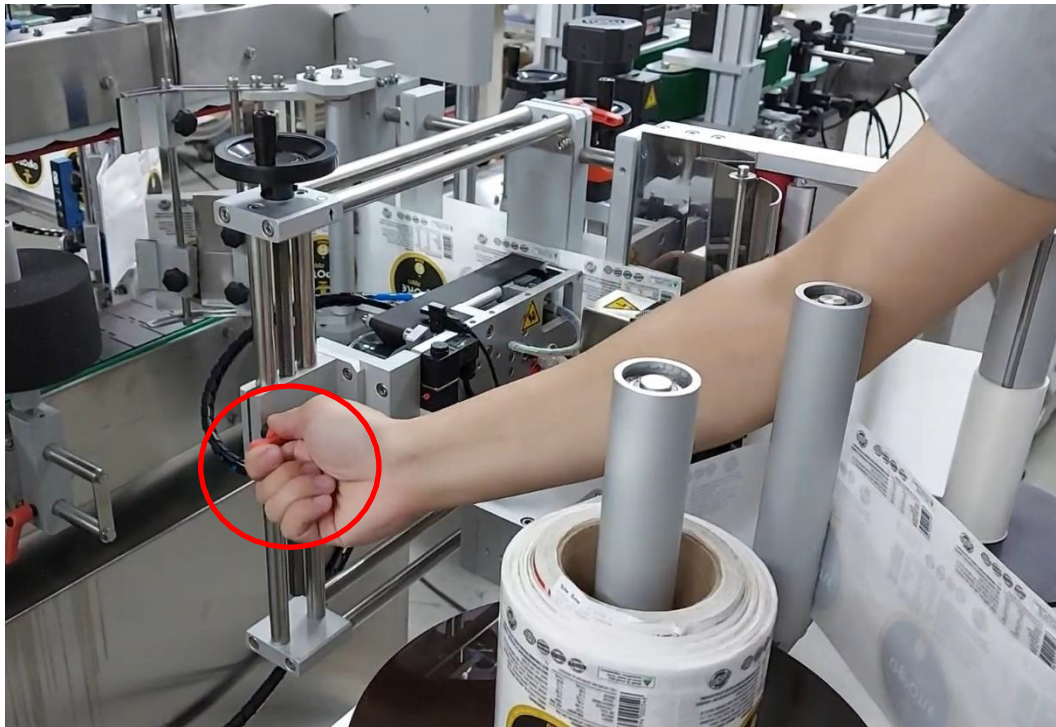



- (5) Loosen the lever.

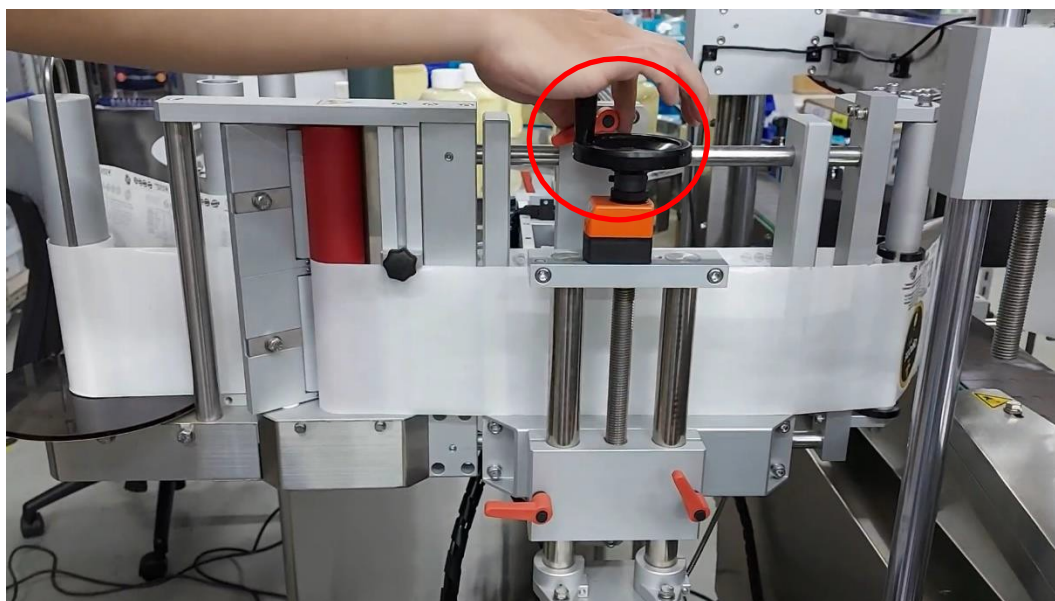

- (6) Move the printer left and right to adjust the printing position. Remember to tighten the lever.

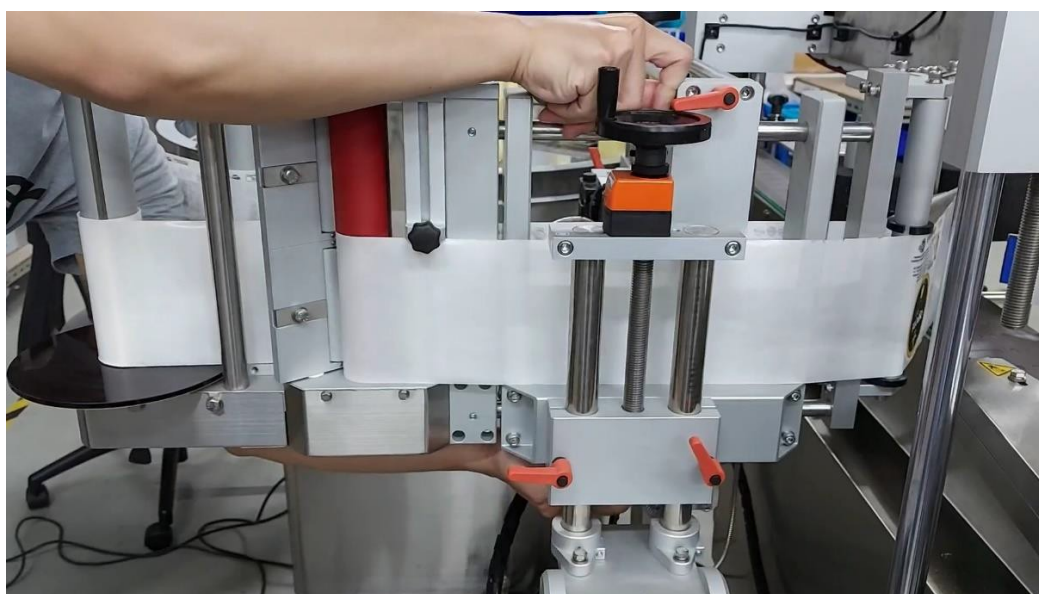



13.4.3 Changing Characters

- (1) Slightly twist the white handle to pull out the stamp.

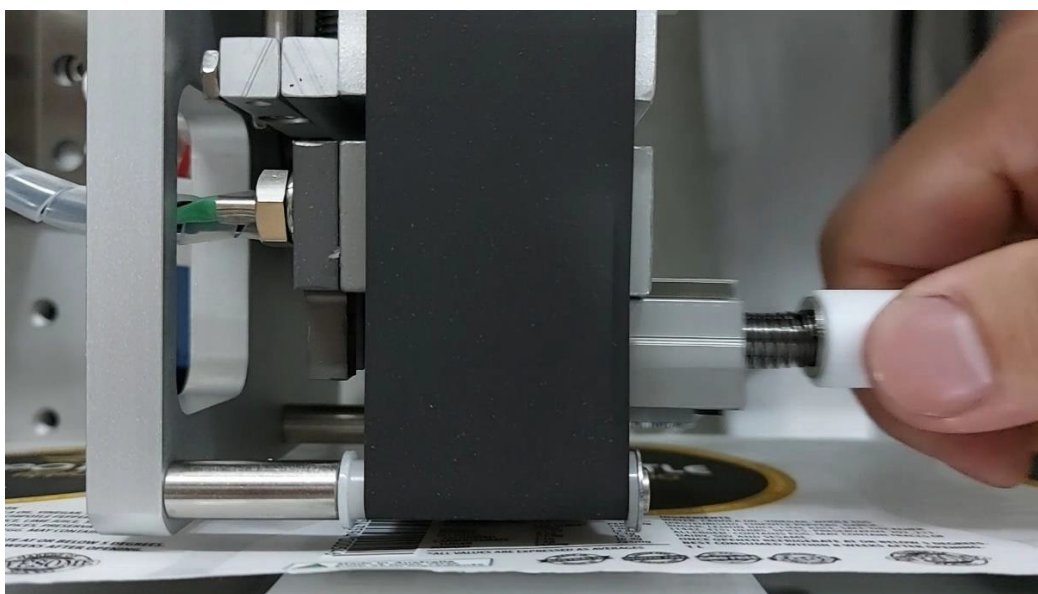
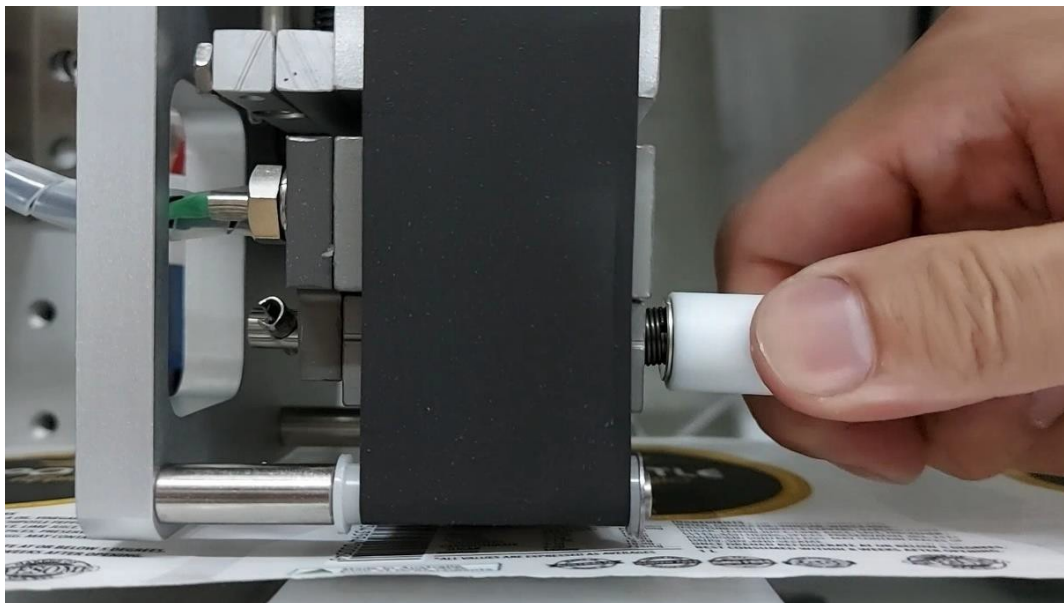



Slide the rubber stop out.

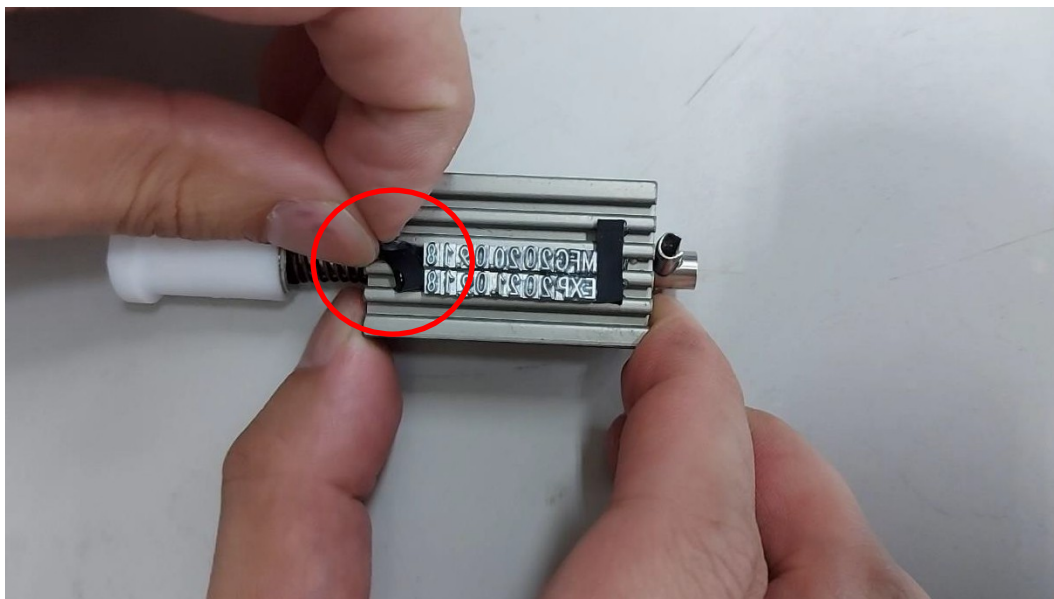

(2) Slide out the type blocks.





- (3) Slide the desired type blocks into the holder in backward order (mirrored). Then, replace the rubber stop.

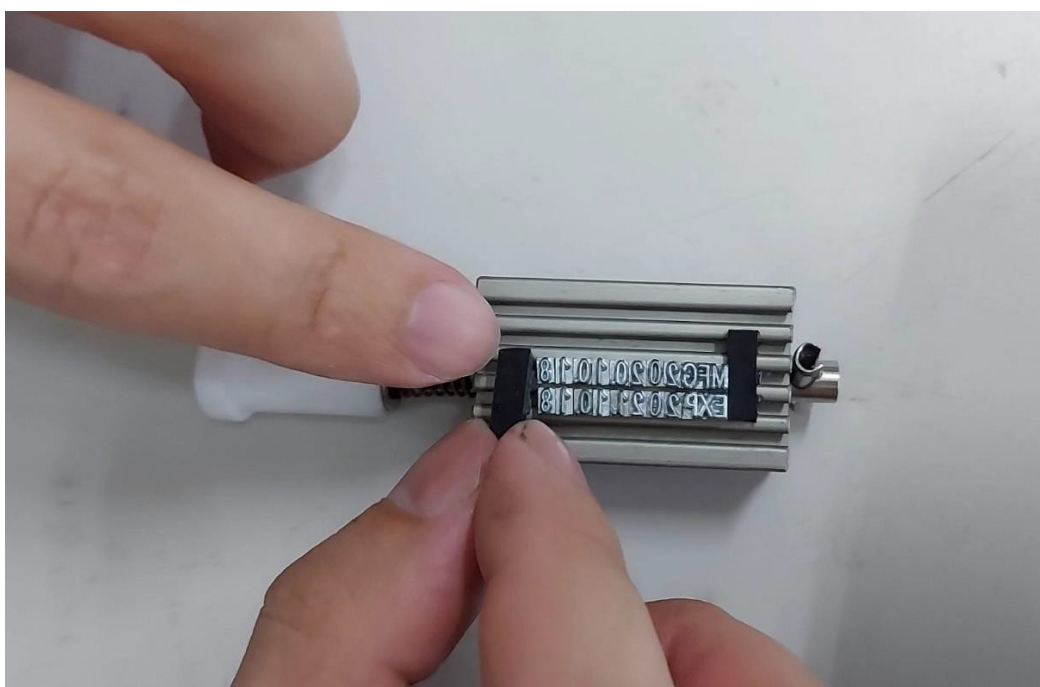



- (4) To place the stamp, match the slot. Then, push in and twist.

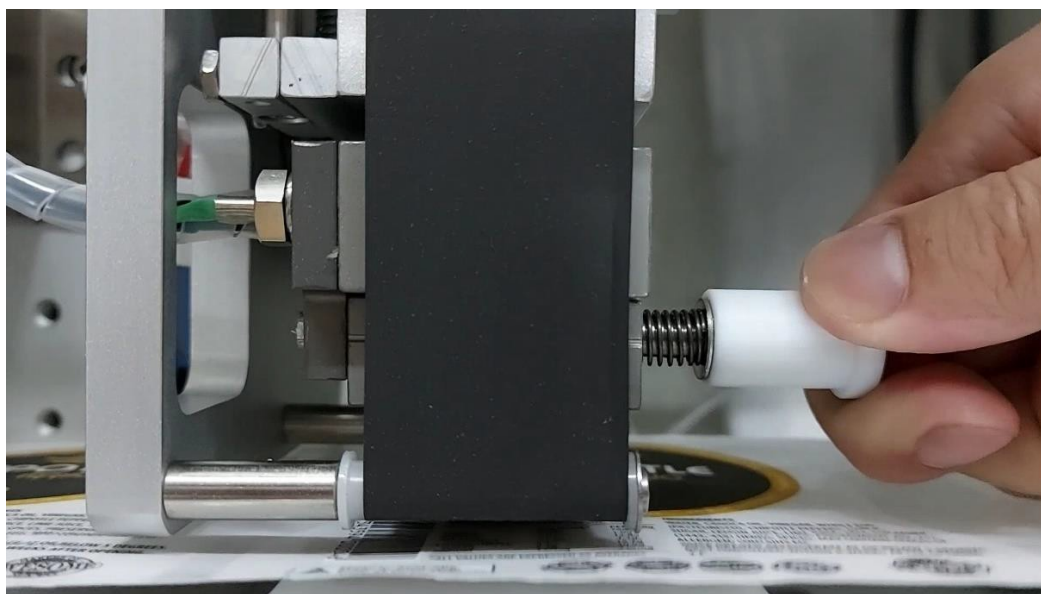
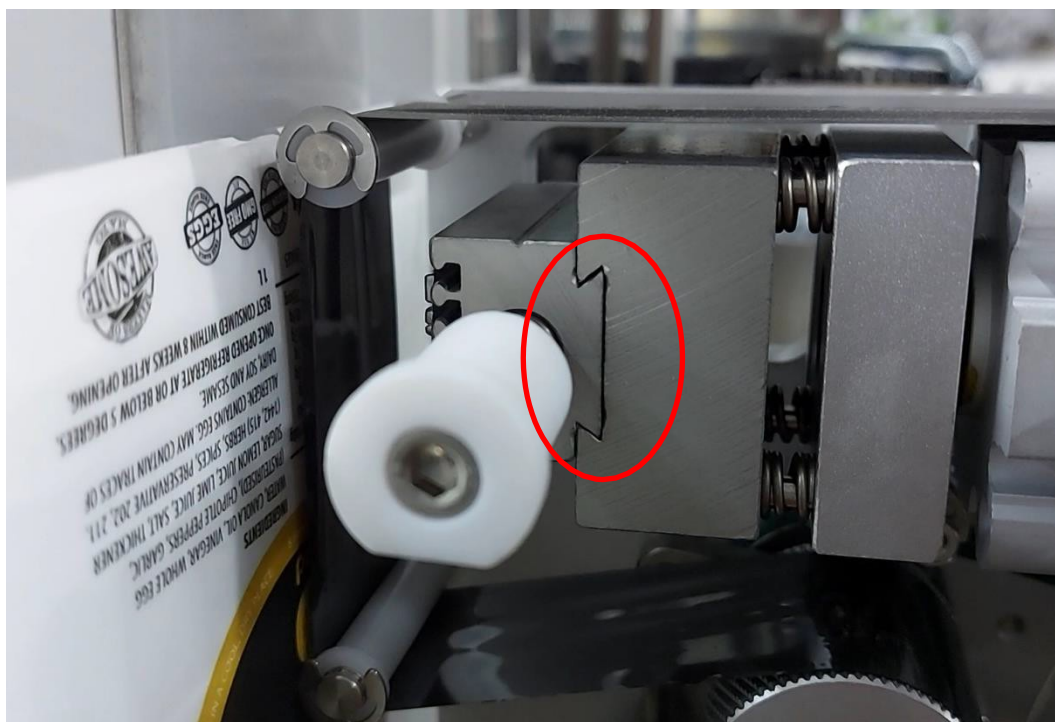



- (1) **Adjustment - Printer - Spacing** The distance (red line) from the transmission wheel set (yellow arrow) to the screw decides the spacing. The longer it is, the larger the line spacing on the code foil will be, and vice versa.

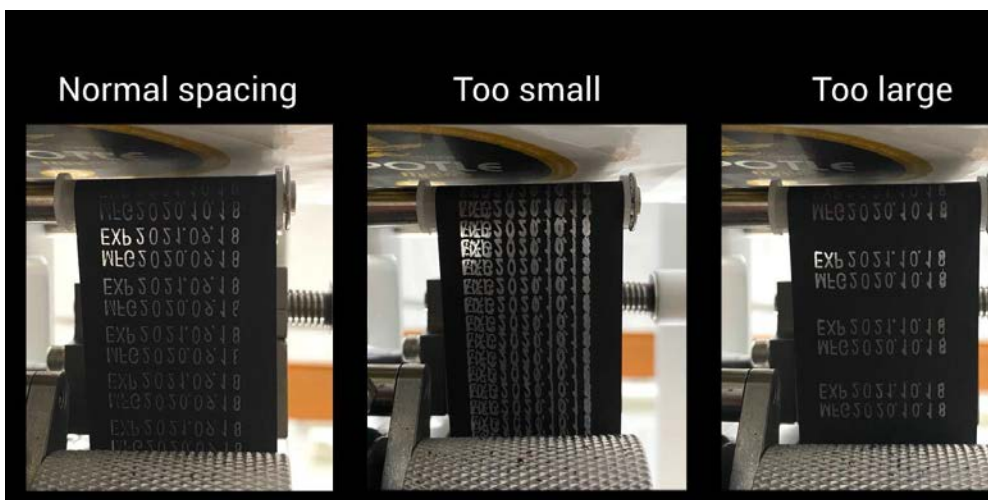
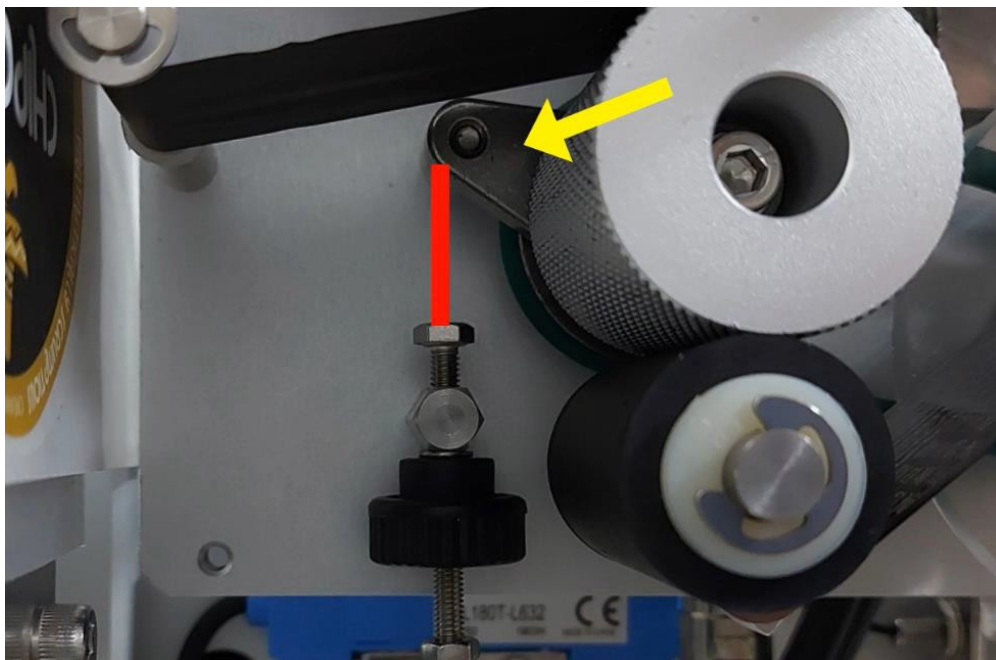



- (2) Adjust the spacing by twisting the knobs.

